

# 2024

THULE GROUP ANNUAL REPORT

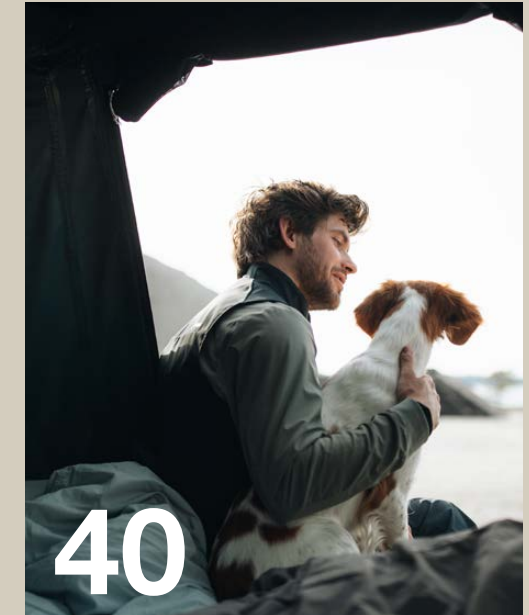

**Active Life, Simplified.**



**OVERVIEW**

Thule Group in brief	<b>4</b>
2024 in brief	<b>5</b>
CEO's statement	<b>6</b>

**STRATEGY & TARGETS**

Strategy	<b>10</b>
Acquisitions	<b>11</b>
Investment case	<b>12</b>
Targets and outcomes	<b>14</b>

**OPERATIONS**

Business concept and brand	<b>16</b>
Product categories and sales	<b>18</b>
Region Europe & RoW	<b>26</b>
Region Americas	<b>28</b>
Product development and safety	<b>30</b>
Manufacturing and logistics	<b>32</b>

**SUSTAINABILITY REPORT**

Sustainability statement	<b>34</b>
General closures	<b>35</b>
Value chain	<b>36</b>
Double materiality assessment	<b>38</b>
Environment	<b>39</b>
Social	<b>57</b>
Business conduct	<b>68</b>

**ANNUAL REPORT**

Board of Directors' Report	<b>73</b>
Risks and risk management	<b>75</b>
Corporate Governance Report	<b>84</b>
Board of Directors	<b>88</b>
Group Management	<b>89</b>
Consolidated income statement	<b>90</b>
Consolidated statement of comprehensive income	<b>91</b>
Consolidated balance sheet	<b>91</b>

Consolidated statement of changes in equity	<b>92</b>
Consolidated statement of cash flow	<b>92</b>
Parent Company income statement	<b>93</b>
Parent Company statement of comprehensive income	<b>93</b>
Parent Company balance sheet	<b>93</b>
Parent Company statement of changes in equity	<b>94</b>
Parent Company cash flow statement	<b>94</b>
Notes for Parent Company and Group	<b>95</b>
Assurance	<b>121</b>
Auditor's report	<b>122</b>

**SUSTAINABILITY NOTES**

About the Sustainability Report	<b>125</b>
ESRS Disclosure	<b>126</b>
Sustainability notes	<b>127</b>
Taxonomy tables	<b>130</b>
Auditor's report on the statutory sustainability report	<b>134</b>
External sustainability assessments	<b>135</b>
Independent assurance statement of greenhouse gas emissions	<b>136</b>

**OTHER INFORMATION**

The share and shareholders	<b>138</b>
Information to shareholders and IR contact	<b>139</b>
Financial definitions and alternative performance measures	<b>140</b>
Five-year overview	<b>141</b>

**The Sustainability Report** is found on pages 33–71 and 125–133 and is published in Swedish and English.

**The Annual Report** is found on pages 72–121 and is published in Swedish and English.

The Swedish version is the original and has been reviewed by Thule Group's auditor.

THULE GROUP IN BRIEF

# Active Life, Simplified.

**Thule Group** is a world-leading global company that develops and manufactures premium products that facilitate an active outdoor life.

**Our products** are linked to a range of outdoor activities, such as transporting bikes by car to the mountain-bike trail or skis to the mountains, with the dog safely in its transportation crate in the back. Or taking a child to preschool on a bike while the laptop is safely protected in a backpack.

**We have** maintained a long-term focus on consumer-driven innovation and sustainable, profitable growth since we were founded in 1942 in Hillerstorp, Småland, Sweden. We are driven by challenges and have the highest standards in terms of safety, function and respect for the environment.

**We are curious** and passionate entrepreneurs, and believe that people have the power to move the world forward.

At each product launch, our ambition is to reveal a glimpse of the future in each product category. We are often global or regional market leaders.

**By 2030**, our company will be twice as big as today and we will have a presence in more product categories, but we will always have the same mantra – safety and functionality in Thule's classic and recognizable designs.

## Sales per product category

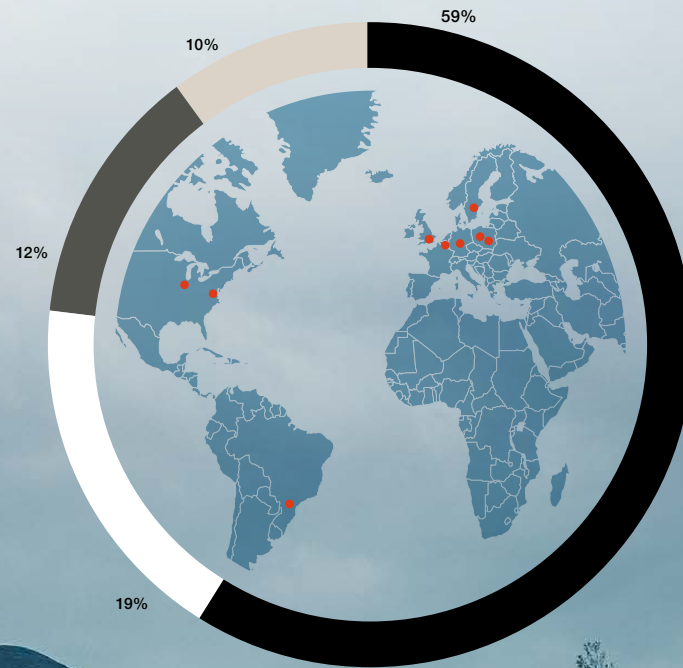

**● Sport&Cargo Carriers, 59%**  
Roof racks, roof boxes, bike carriers, rooftop tents, water and winter sports



**● RV Products, 18%**  
Awnings, bike carriers and tents for recreational vehicles and caravans



**● Juvenile & Pet, 13%**  
Bike trailers, child bike seats, strollers, car seats and dog transportation crates



**● Packs, Bags & Luggage, 10%**  
Duffel bags, backpacks, luggage and laptop bags for everyday use, hiking backpacks, camera bags and cases for consumer electronics

**● Manufacturing sites**  
9 manufacturing sites in 7 countries

9.5 bn in sales

2,800 employees across the world

35 sales offices

138 markets



2024 IN BRIEF

# Back to growth despite challenging market

**Thule is performing well** and has reported both growth and improved profitability in a challenging market. In 2024, we launched more new products than ever before in Thule's history. We also created two new product categories (car seats and dog transportation) and added another category through acquisitions.

**Our acquisition of the market leading brand Quad Lock** was completed in December. Quad Lock is a leader in performance phone mounts for mountain bikes, motorcycles and all-terrain vehicles. Quad Lock has sales of approximately SEK 1.4 billion and a high operating margin.

**For the full year 2024**, sales rose 4.5 percent (3.5 percent organically). The growth was clearly driven by new products. The adjusted operating margin improved to 17.0 percent (16.5), despite higher costs for product development and launches. Cash flow increased to SEK 2,310 million (1,850 million).

**Thule's sustainability work** is well integrated into its business. Our goal with each new version of a product is to reduce emissions. For example, the carbon footprint of the Thule Easyfold 3 bike carrier launched during the year was approximately 50 percent lower than that of the previous version.

NET SALES PER GEOGRAPHICAL AREA, %

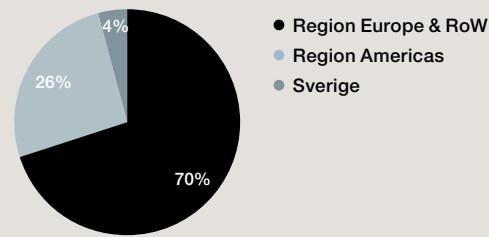

SALES BY PRODUCT CATEGORY, %

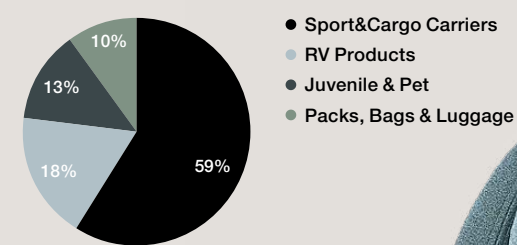

FINANCIAL INFORMATION IN BRIEF

SEKm	2024	2023	Change, %
Net sales	9,541	9,132	+5
Operating income	1,622	1,505	+8
Operating margin, %	17.0	16.5	+0.5*
Net income	1,122	1,099	+2
Cash flow	2,310	1,850	+25
Earnings per share, SEK	10.59	10.45	+1

\*referring to percentage points

NET SALES, SEKm

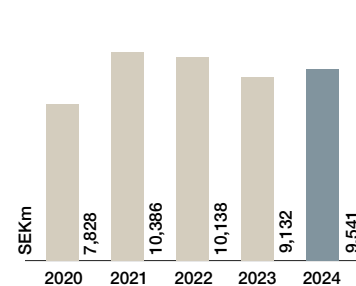

EBIT AND EBIT MARGIN

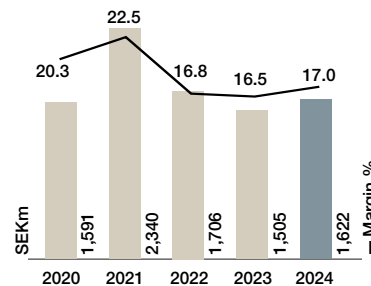

NET DEBT

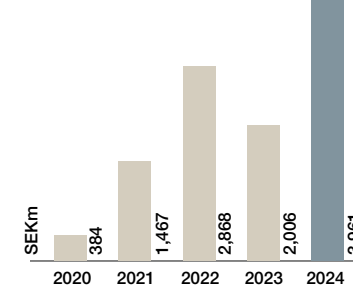

GREENHOUSE GAS EMISSIONS

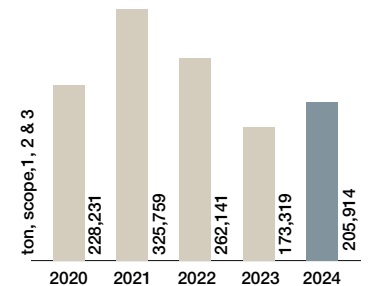

CEO'S STATEMENT

# A successful Thule on its way to the next level



”  
Dog products has made the best start of any product category in Thule’s history.”

**Thule has proven that growth and improved profitability are possible even in a challenging consumer market. In 2024, we launched more new products than ever before, added three new product categories and strengthened our direct-to-consumer channel. By building on our strengths and scaling up what we excel at, we are well on track to reach our financial targets for 2030. We are keeping our foot on the gas, our eyes firmly on the road, and heading to the next level – a significantly larger Thule with even higher profitability.**

The year has been characterized by continued challenges in the consumer market due to global uncertainties and high interest rates. Consumers have kept a tight grip on their wallets, and the much-anticipated economic recovery has taken longer than expected. Thule has performed very well despite these challenging market conditions. A broad product portfolio, high brand loyalty and customers willing to pay for premium products have enabled us to deliver growth of 5 percent and an improved operating margin of 17.0 percent. I am very proud of the results we have achieved despite the strong headwinds facing our industry.

#### NEW PRODUCTS DRIVE GROWTH

New products are clearly driving our growth. In 2024, we launched more new products than ever before, and we also won more design awards than in any previous year. We achieved all of the above while concurrently improving our profitability.

Updated bestsellers such as our market-leading jogging and all-terrain stroller Thule Urban Glide, our updated Thule Chasm duffel bag and the new generation multisport and bike trailer, Thule Chariot have delivered excellent growth for us. Our focus has been on releasing new versions of several of our premium products that are popular among groups with high purchasing power, while increasing our lead over competitors.



**Without my colleagues' curiosity, passion and desire to constantly find even better solutions, we would not be in the position where we are today, with more than 1,000 patents and a position as the global market leader in our key product categories."**

## Market trends

### More and more people want to experience the outdoors

People around the world are increasingly attracted to outdoor activities. More time and money are spent on shared experiences with family and friends.

### Brands connected to lifestyle create loyalty

Brands that are used in connection with positive feelings are strengthened, which makes it easier to build consumer loyalty, sales growth and healthy profitability.

### Increasing demands for sustainability

Meeting consumer expectations has become much more demanding in terms of reduced resources, long product lifetimes, respect for human rights and transparency.

### SUCCEEDING IN SEVERAL PRODUCT CATEGORIES SIMULTANEOUSLY

Thule's market-leading positions and its ability to develop them is one of the company's greatest strengths. In combination with Thule's strong brand that stands for safe, user-friendly and sustainably designed products, this sets a clear path forward for Thule as a leading global lifestyle company. We call our strategy "Big in pockets, united by the Thule brand." We identify attractive categories (pockets) that are compatible with our brand in growing markets where customers are willing to pay for premium products. Barriers to entry such as regulations or safety requirements are to our advantage. Our ambition is to grow in more product categories going forward and we added two new categories during the year – car seats and dog transportation products.

Dog products has made the best start of any product category in Thule's history. Our first product, the Thule Allax dog crate, quickly began to capture market share. Later in the year, we launched Thule Bexey, our bike trailer for transporting dogs – and more dog products are coming in 2025. The category is well suited for Thule: premium products for people who want to be active and who are willing to pay for safety and user-friendliness as well as a growing market and a clear connection to our brand identity – "Bring your life".

Our car seats have also been well received,

with positive media exposure, design awards and good distribution with key retailers. In the autumn, the car seats came top in the ADAC test, Europe's most important consumer test. We commenced sales in all three DACH region countries in May, and decided in the fourth quarter to launch our car seats in an additional 23 European countries. We are continuing to develop products and will launch additional models for somewhat older children in 2025.

One of my priorities as CEO is to ensure that we are successful in several product categories simultaneously. Focusing on one thing is easy; it is much harder to do many things well at the same time. Thule has been good at growing its market-leading positions for decades and we aim to continue to do more of the same, but on a larger scale.

### ACQUIRING MARKET LEADERS IN ATTRACTIVE NICHES

Thule has successfully expanded its number of product categories over time, both organically and through acquisitions. Organic growth will remain the basis for our growth. Before we acquire a company, it must meet the stringent requirements we set for a product category. Something few companies are able to meet, but for those that do, acquiring them is an effective strategy for entering new markets.

In late 2024, we acquired Quad Lock, the global market leader for performance phone mounts for cyclists, motorcyclists and other adventurers. As a global market leader in its niche, with a growing product category, the best products in the market, and a strong history of innovation and product development, Quad Lock is a very good fit with our strategy. From a consumer perspective, with Thule standing for quality, safety and facilitating an active outdoor life, the acquisition makes an unusually good fit, which lays the foundation for including Quad Lock in the future of Thule's brand. Quad Lock has sales in more than 100 countries and reported sales for the last twelve months of about SEK 1.4 billion together with an EBITDA margin of 25 percent. Together, we have many opportunities to develop.

### INCREASED VISIBILITY TO CONSUMERS.

While we know that many of our customers genuinely appreciate our products, few know about our entire offering. We will continue our long-term initiatives to be more easily and effectively visible in stores, events and the media, to commence sales to more countries via thule.com and to adopt new measures to engage our fans.

### STREAMLINING FINANCES GROWTH INITIATIVES

We will continue to increase efficiency and capacity utilization. Although we have a well-functioning supply chain, at Thule, we believe in continuous improvement. This is true not only in terms of our product offering but is just as relevant to inventory levels and logistics. Moreover, streamlining helps to finance further growth initiatives.

### SUSTAINABILITY THAT MAKES A DIFFERENCE

For those of us with the outdoors in our blood, taking care of our planet is self-evident, as is treating everyone we do business with in the Thule spirit. We endeavor daily to develop more sustainable solutions. For example, when developing a new product, we evaluate the product materials to see how they contribute to CO<sub>2</sub>eq emissions. With Thule EasyFold 3, which we launched in 2024, we were able to reduce emissions by 50 percent compared with the previous version. We achieved this by reducing the total amount of aluminum, using aluminum produced by hydropower and using recycled plastics where possible. Such improvements are important when consumers choose a product and are equally important for our plans to reduce emissions in line with the Science Based Targets initiative.

”

**Despite the market's short-term challenges, more and more people want to live active lives, providing us with a long-term tailwind. We have strong market positions, and an outstanding ability to develop world-leading products that drive profitable growth.”**

## Priorities for 2025

1. Continue to invest in product development.
2. Succeed in several product categories simultaneously.
3. Increase our visibility for consumers.
4. Increase efficiency and capacity utilization in our supply chain.

Our ambitious work with sustainability was recognized in early 2025 by Morningstar Sustainalytics, who ranked us among the 50 best companies in the world from the 15,000 companies that they follow. We are very proud of this distinction since it demonstrates that we are on the right path.

### HIGH PACE CONTINUING INTO 2025

We invest heavily in our own capabilities and our successes are generated by our 2,800 employees. Without my colleagues' curiosity, passion and desire to constantly find even better solutions, we would not be in the position where we are today, with more than 1,000 patents and a position as the global market leader in our key product categories. In 2025, we will continue with product launches expeditiously, particularly of bestselling products that are slightly below the premium price range – a segment that is expected to take off as the market improves. We will continue to build toward future market leading positions in our new categories of car seats and dog products, even if, as with roof boxes, it takes 25 years. We will increase our visibility to consumers, both through our own stores and online, and we will continue to increase efficiency and capacity utilization in our supply chain.

I am convinced that over time, our global market-leading positions in several product categories will be joined by more categories.

The passion for the brand, an active life outdoors, and creating the most amazing products, carries us forward regardless of market conditions, global turmoil or new trends. We have stepped up a gear and are moving to the next level. Despite the market's short-term challenges, more and more people want to live active lives, providing us with a long-term tailwind. We have strong market positions, and an outstanding ability to develop world-leading products that drive profitable growth. Our most important success factor is people – our employees, customers, end consumers and shareholders. Together, we are building a significantly larger Thule with even higher profitability.

I look forward to another eventful year together with you!

Malmö, April 2025

Mattias Ankarberg  
CEO and President



# Strategy and targets

STRATEGY

# Big in pockets, united by the Thule brand

**Thule’s market-leading positions and its ability to develop them is one of its greatest strengths. In combination with Thule’s strong brand that stands for safe, user-friendly and sustainably designed products, this sets a clear path forward for Thule as a leading global lifestyle company.**

## Focus on market-leading positions in attractive product categories

We create the most value where we have market-leading positions. Ninety percent of our value creation since 2014 has come from a handful of market-leading positions. Therefore, we will continue to build leading positions in attractive product niches or “pockets”.

A market niche is attractive to us if it fits with the Thule brand, shows growth and has customers willing to pay for premium products. Barriers to entry, such as regulations or safety requirements, which create some degree of complexity, are to our advantage. We are aiming for categories that grow through innovation.

[Read more on page 18.](#)

## Product-driven growth to expand our market position

Thule is a product-driven company that for more than 80 years has consistently managed to create an edge through innovation. We will continue to do so, by investing heavily in our own abilities, particularly when it comes to quality and innovation. We have won countless design awards and are focused on finding the combination of functionality and design that creates bestselling products.

[Read more on pages 18 and 30.](#)

## Acquisitions to complement organic growth

Thule has successfully expanded its number of pockets, both organically and through acquisitions. Organic growth will remain the basis for our growth. We see acquisitions as an effective way of adding new categories. Before we acquire a company and its products, they must meet the stringent requirements we set for a product category. Few companies are able to do so, but for those that do, acquiring them enables us to quickly enter a new market.

[Read more on page 11.](#)

## Thule’s premium brand and culture

The Thule brand is strongly associated with safe, user-friendly and sustainably designed products. The world’s leading outdoor enthusiasts use Thule’s products and we have an extensive history with generations of users creating a relationship with the brand and our products.

[Read more on page 16.](#)



ACQUISITIONS TO COMPLEMENT ORGANIC GROWTH

# The acquisition of Quad Lock creates opportunities for growth

**At Thule Group, acquisitions are part of our strategy for generating growth. The companies we acquire should be market leaders in an attractive niche and their products should drive growth and be innovative in their field. In addition, the connection to the Thule brand and culture is an important factor. In 2024, Thule Group acquired one large and one small company.**

In December 2024, Quad Lock joined Thule Group. Quad Lock is the market leader in performance phone-mount solutions, giving cyclists, motorcyclists and other adventurers access to their cellphones while being active. Through constant innovation and their high product quality, Quad Lock has built a leading position in some 100 countries worldwide. At the time of acquisition, Quad Lock had annual sales of approximately SEK 1.4 billion and an EBITDA margin of 25 percent. The company's head office is in Melbourne, Australia.

Direct-to-consumer sales account for 75 percent of Quad Lock's sales, compared with about 7 percent for Thule. This allows Quad Lock to leverage Thule's broader network of retailers.

Quad Lock has a strong position among cyclists – one of Thule's main target groups – opening the way for joint development projects going forward. Quad Lock also has a large customer group within motorsports, which creates interesting new opportunities for the future.

In early July, Thule completed a minor acquisition of the German company, Reacha, which has an innovative product that enables the transportation of a kayak or SUP on a bike trailer. In 2023, the company had sales of approximately SEK 9 million.

**1.4** SEK billion in sales  
**25** EBITDA margin, %

**100** Sales in 100 countries  
**75** Direct-to-consumer, %

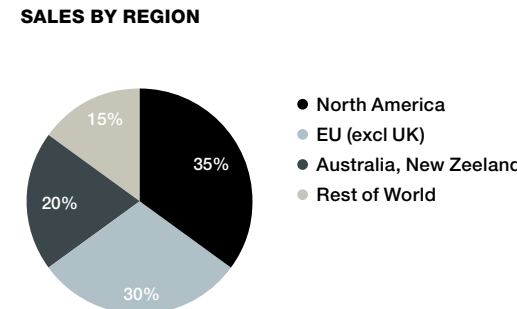

Interview with **Baptiste Chaussignand**, Director Category Management Bike at Thule

**What kind of fit is Quad Lock with Thule?**

I was very happy when I heard about the acquisition plans. As a passionate cyclist, I have been using Quad Lock's products for many years and know that they have the same sense of quality and innovation as we do. Furthermore, we got to know each other during the acquisition process and their values seem very close to our way of thinking.

**What exactly are "performance phone mounts?"**

The Quad Lock protects your phone from damage, not only if you happen to fall, but also from vibration. It takes advanced technology to prevent today's sensitive phones from being damaged when a mountain bike or motorcycle is being driven off-road at full speed. Quad Lock has also come a long way in terms of wireless charging and integration with e-bikes, making the hardware part of the bike itself.



**What is it that has made Quad Lock so popular with its customers?**

In addition to the company's high-quality products, they understand that users want everything to be connected. They have a system of different mounts and shells that allow you to move your phone between the bike, car, motorcycle, stroller and desktop. If you buy a new phone, it's easy to upgrade and still have everything fit together. Quad Lock products make it easy for you to use your training apps and navigator, and to keep in touch with your friends while you're on the move.



**"As a passionate cyclist, I have been using Quad Lock's products for many years and know that they have the same sense of quality and innovation as we do."**

TARGETS AND OUTCOMES

# Financial targets

**Thule Group's long-term financial targets for 2030 has been set by the Board of Directors and published in 2022.**

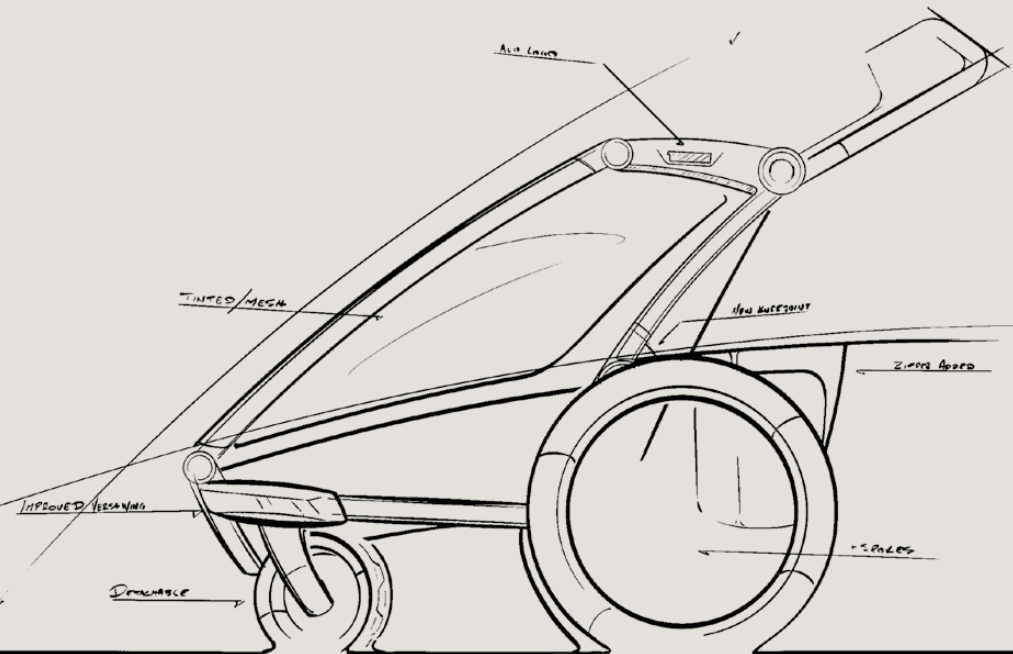

## Turnover

Sustainable, long-term sales growth is at the core of the company's value creation. A focus on growth drives an organization to perform better and fosters a winning culture.

**LONG-TERM TARGET** **SEK 20<sup>bd</sup>**

Corresponding to average currency-adjusted annual growth (CAGR\*) of +11.8 percent from 2023 until 2030.

**OUTCOME 2024** **SEK 9.5<sup>bd</sup>**

Net sales

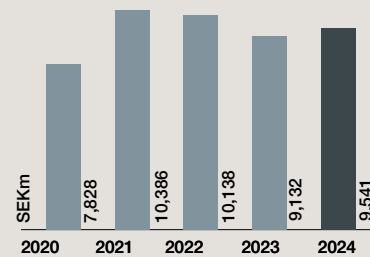

## FUTURE FOCUS

- Continued investment in launches of improved products.
- Expansion into additional product categories.
- Become more visible to and sell more directly to consumers (DTC).

\*CAGR= Compound Annual Growth Rate

## Profitability

As a brand-driven lifestyle company, our growth must drive profitability and strengthen our earnings.

**LONG-TERM TARGET** **>20%**

EBIT margin.

**OUTCOME 2024** **17.0%**

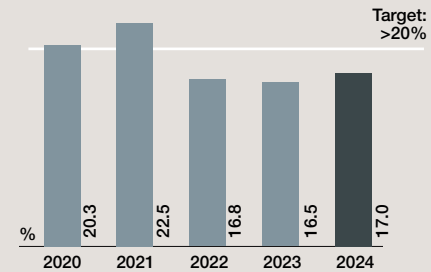

## FUTURE FOCUS

- Continued investments in efficiency.
- Optimization of warehouse capacity.
- Continued cost-conscious culture.

## Dividend

We intend to distribute at least 75 percent, in relation to net profit, in the form of ordinary dividends.

**LONG-TERM TARGET** **>75%**

Proportion of annual net income to be distributed.

**OUTCOME 2024** **75%**

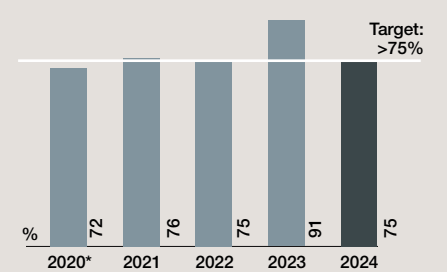

## FUTURE FOCUS

- Continued strong cash conversion.
- Responsible investments that provide good returns and maximize shareholder value.

\* Excluding the extraordinary dividend for 2019, which was postponed due to the pandemic and paid in 2020.

TARGETS AND OUTCOMES

# Sustainability targets

Thule Group has signed the global commitment to achieve Net Zero greenhouse gas (GHG) emissions throughout the value chain by 2050 (in line with the Paris Agreement target of no more than a 1.5°C increase in global average temperatures). Furthermore, the Science Based Targets initiative (SBTi) has validated and endorsed our GHG reduction targets throughout the value chain.

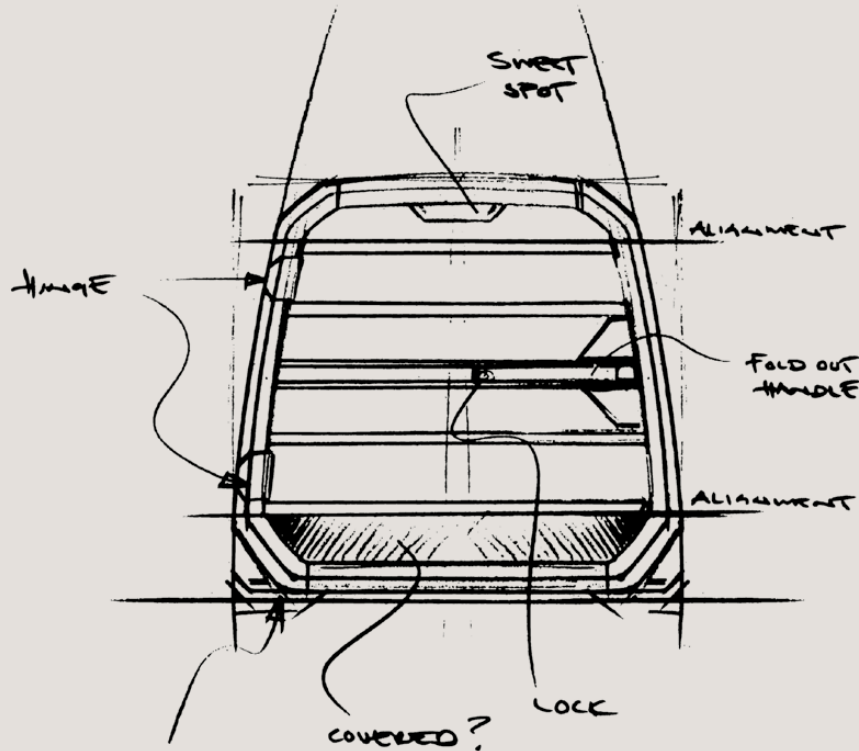

## Greenhouse gases

We aim to reduce our environmental impact by reducing our emissions of direct and indirect greenhouse gases.

**LONG-TERM TARGET** **-90%**

By 2050, Thule Group is to have achieved an absolute reduction of 90 percent in greenhouse gases compared with 2019.

**OUTCOME 2024** **-23%**

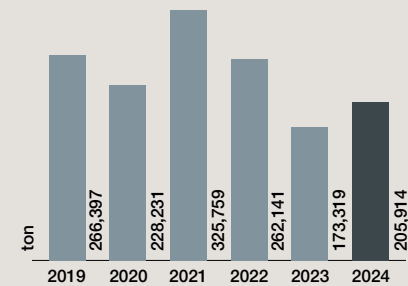

### FUTURE FOCUS

- All new development projects that meet certain financial thresholds in the second year of sales, to reduce their CO<sub>2</sub>e emissions by a minimum of 30 percent compared to a defined benchmark product.
- Use of eco-design models, material emissions database and collection of previous life cycle assessments to improve product climate impact.
- Circular thinking through extended product lifetimes and modular focus in product families, which simplifies recycling and expands the offering of spare parts.
- Increase the share of recycled materials or materials with lower greenhouse gas emissions without compromising the product's safety or lifespan.

## Health and safety

We are to provide safe and secure workplaces and have a zero-accident vision.

**LONG-TERM TARGET** **-50%**

By 2026 the number of accidents at our workplaces should be 50 percent less than in 2020.

**OUTCOME 2024** **-13%**

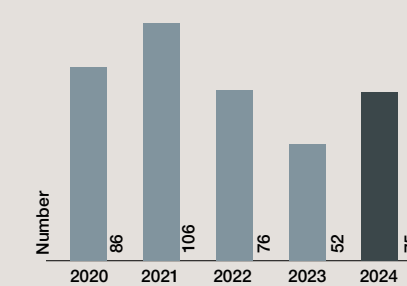

### FUTURE FOCUS

- By 2025, all facilities are to be ISO-45001 certified.
- Further systematic management of the work environment with continuous incident reporting and follow-up in order to reduce the number of accidents.
- In-house training for increased awareness and learning.

## Supplier audits

We continuously audit our suppliers by means of annual risk assessments based on countries and product categories.

**TARGET** **>90%**

Audit of high-risk suppliers corresponding to >90 percent of the purchasing volume (SEK) from these groups on a rolling 12-month basis.

**OUTCOME 2024** **98%**

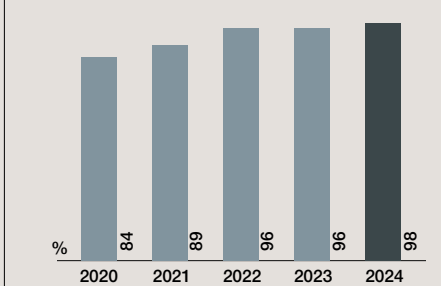

### FUTURE FOCUS

- Further categorization and risk analyses by country of operation and product category.
- Audits of risk suppliers and requirements for action in relevant cases.

# An investment case on a strong foundation

Thule's investment case is based on a history of more than 80 years in innovative product development, a globally recognized lifestyle brand and solid long-term efforts on climate and environmental issues as well as human rights. Thule conducts efficient and flexible production in close proximity to the largest of the 138 markets where its products are sold. Growth benefits from a global trend that has been established for many years by which more people want to live an active life and there is a constantly growing interest in outdoor and leisure activities.



Thule Allax, Thule Chasm

**R&D COST IN % OF SALES**

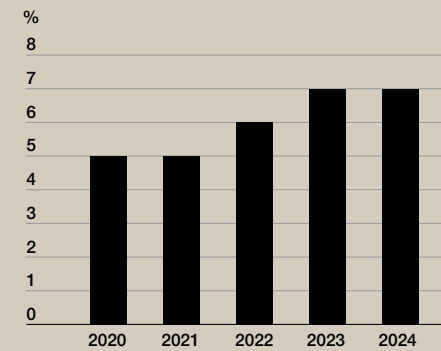

**NET SALES AND EBIT MARGIN**

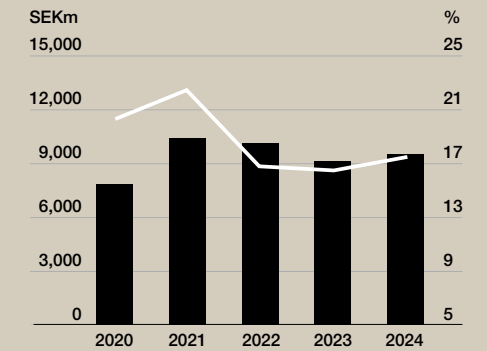

## Thule – a globally recognized premium brand in a market with tailwinds

Thule's products have a premium position in all product categories and markets, and a well-established and loyal community of customers. The positive market trend is created by more and more people wanting to live active lives.

## Proven capacity for innovation and award-winning design

7 percent of the Group's sales is invested annually in product development. Half of its sales is derived from products that were launched in the past three years. The high quality and functionality of the products, and their smart solutions, combined with a clear focus on safety and thoughtful eco-design, brings recurring international awards and success in external testing throughout the world.

## Efficient, flexible and safe manufacturing and supply chain

Nine own production facilities that are located close to our primary markets, with proven ability over many years, to flexibly and efficiently manage the entire supply chain, from the sourcing of

raw materials to deliveries to customers and consumers, with a focus on employee safety, and a strategy for achieving net-zero carbon emissions.

## Sustainability as a part of our core business

Precision, cost awareness and a concern for people and the environment have long been important aspects of Thule's history. Thule pursues a comprehensive and successful sustainability agenda with long-term climate goals based on the Science Based Target initiative (SBTi), the Net Zero targets, and the UN's 2030 Agenda for Sustainable Development.

## Proven ability to grow profitably

Thule has been characterized by profitable growth for many years. By developing existing market positions and adding new product niches, Thule generates both short and long-term growth. With premium products in high demand that have high gross margins, Thule maintains high profitability also as it expands. A larger Thule will achieve more economies of scale, which act as a catalyst for even higher profitability over time.

# Bring your life



# Thule's business concept and strong brand

Thule Group is a global lifestyle company that develops, manufactures, markets and sells high-quality, smart and well-designed products. In 2024, we launched more products than ever before and broke records in prestigious design awards. It was a special honor to receive the 2024 Red Dot Design Team of the Year award, which places us on par with reputable brands such as Apple, Porsche and Sony.



Thule Chasm

## Our business concept

is to offer high-quality products with smart features and a sustainable design that make it easy for people across the globe to live an active life.

## BRANDS CONNECTED TO LIFESTYLE CREATE LOYALTY

Brands that are used in connection with positive feelings are strengthened, which makes it easier to build consumer loyalty, sales growth and healthy profitability. Lifestyle brands that aim to be more than just a product and deliberately work to create a stronger connection to their consumers have greater possibilities of being long-term winners.

The Thule brand is global and strong, and has an extensive history, with generations of users creating a relationship with the brand and our products.

Through close dialog with our brand ambassadors and passionate users, we have gained deep insights into trends in the sports and outdoor sector, and we currently hold a leading position in our product areas.

The brand's DNA is based on safe, user-friendly and sustainably designed products, and is closely associated with the motto *Bring your life*.

**RECORD SUCCESS AT RED DOT AWARDS AND IF DESIGN AWARDS**

In addition to the prestigious title of 2024 Red Dot Design Team of the Year, Thule received a further 11 Red Dot Awards and 12 iF Design Awards in 2024. The awards are among the world’s most prestigious design prizes and included brand new products in new categories as well as new versions of existing popular products such as the Urban Glide stroller. Thule was recognized for its timeless design, seamless functionality and style. The fact that the entire design team was honored in this way is a testament to the collaborative spirit, creativity, and passion for pushing boundaries that exist within Thule.

**ENGAGING MARKETING AND CLOSE DIALOG**

The basis for product design and development is having solid knowledge and experience of how consumers use and experience our products. Our collaboration with the best retailers in each product category and market, combined with visually inspiring and engaging marketing materials provided by Thule, fuels growth.

Marketing and sales take place in brick-and-mortar stores as well as in digital channels, both through our retailers and directly to consumers. In 2024, we expanded direct-to-consumer sales via our Thule.com website, creating opportunities for us to penetrate new markets and complement our sales through retailers.

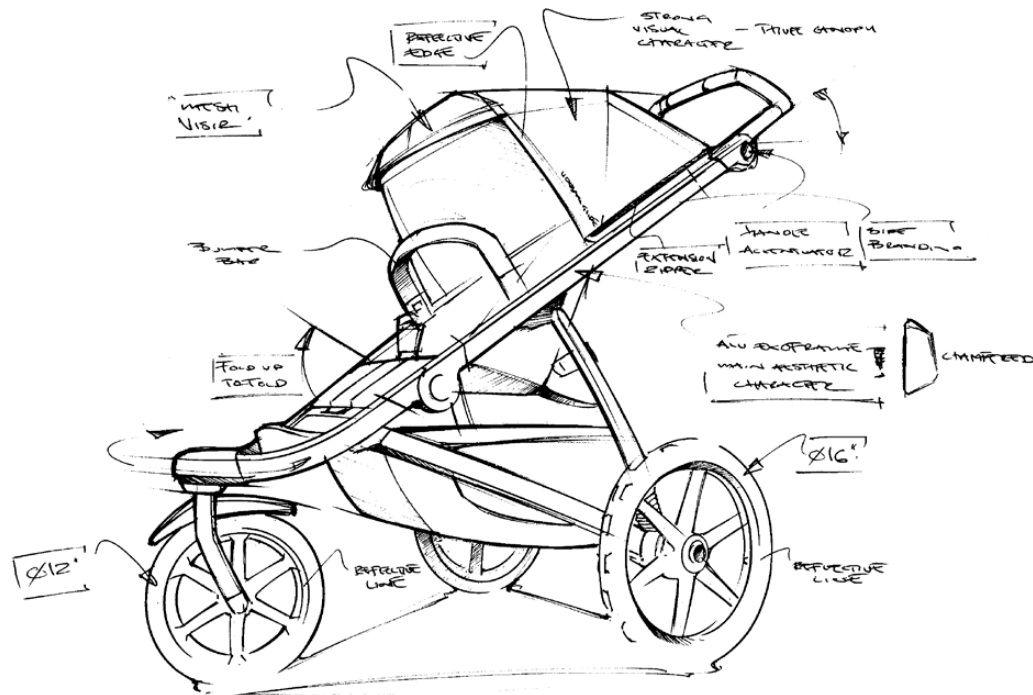

Interview with Tina Liselius, VP Global Brand at Thule

**What is the recipe for success behind your market-leading position?**

That we are constantly on the move. It’s in our nature not to rest on our laurels. We invest to increase the lead we have on our competitors. Our test and development center is constantly raising our level of ambition and improving the impact of our innovations, which has resulted in the filing of more than 1,000 patents. Breaking barriers and being creative is what we love.

**You have been working here for more than 10 years. What has been the biggest change?**

That there is now a whole different level of completeness. Our products complement each other and are all based on the same high quality, smart features, sustainable material choices and long product lifespan. We are finding that consumers who have our roof box, tent or bike carrier, would also like to have our bags, because they trust the brand.

From a broader global perspective, we see how safety has become cool. In the 90s, almost no skiers had helmets or spine guards. Now just about everyone has them. It’s a trend we are seeing across all sporting activities and our product development is based on an extremely well-developed safety mindset, particularly when it comes to our new products, such as car seats and dog transportation crates. This is where we are making a difference.

**“Breaking barriers and being creative is what we love.”**

**Which accomplishment are you most proud of?**

Our incredible successes in 2024, with records both in design awards and in performance in quality tests, is based on the tireless dedication, creativity and hard work of our amazing design and development team. Our journey has always been fueled by a passion to develop products that are not only innovative but also resonate deeply with the needs and aspirations of our users. That’s what I’m proud of.

I should also credit our ambassadors who share their passion for an active life in nature through their own social media channels and those hosted by Thule. This allows us to reach out both to their and to our followers with credibility. Several ambassadors also participated in the Innsbruck event for rooftop tents, where visitors did morning exercises with Anja Pärson, for example.

**What challenges do you see ahead?**

Educating car drivers beyond the Nordic countries that small children should ride backwards in the car and that dogs and passengers are both best served by transporting the dog in a Thule crate in the back of the car. Sweden has a tradition of keeping a safety mindset that we can and want to export in order to protect more people, but it requires perseverance and patient explanation in some markets. It’s a challenge we look forward to taking on.

**What is your favorite product?**

When my children were small, it was definitely the Thule Urban Glide stroller, but today, I’d say our amazing Thule Approach rooftop tent. What a great view and freedom it gives us!

# Product categories

**Thule has four product categories. Sport&Cargo Carriers is the largest, followed by RV-Products, Juvenile & Pets, and Packs, Bags & Luggage.**



## Sport&Cargo Carriers: Strong market trend in all categories

Thule is a market-leader in Sport&Cargo Carriers, with around half of the global market. We offer the market's widest range of products that attach to the car, such as roof boxes, bike carriers and rooftop tents. It should be easy to place the entire family's luggage in the roof box, bring the bikes to the mountain-bike trail and skis to the slopes.

We drive growth in this category through innovative product launches and intense focus on supporting retailers with store concepts, online tools and through inspiring marketing.

The market is very positively influenced by the global sports and outdoor trend, as well as the need for people to bring larger items with them when out and about, such as heavier e-bikes that require innovative and robust transportation solutions. Some cities and countries are also investing significant resources to increase the use of bikes as a mode of transportation. This is driving higher demand for and interest in our products.

Our Sport & Cargo Carriers products are well suited to being sold online and the percentage of these products being sold directly to consumers has increased. On the other hand, there is a high demand for support in terms of advice and assembly through retailers. Therefore, Thule aims to maintain a high proportion of sales through retailers in the future.

During the year, we launched upgraded versions of some of our bestselling roof boxes and bike carriers, as well as a brand-new tent.

Thule ReVert is adapted to vehicles in the US market and enables the transportation of up to six bikes vertically from the back the car. It is the only hanging bike carrier in the market that features a lifting aid when being raised or lowered.

Thule Motion is the world's bestselling roof box. A generation 3 version was launched in 2024, featuring improved aerodynamics, which is increasingly important with more electric cars on the road.

The world's first tent adapted to the tow bar, Thule Outset, has been launched. Like Thule's rooftop tent, the Thule Outset folds up in minutes. Having the tent attached to the tow bar instead of the roof, makes it easier to get in and out of, and you can also disconnect the tent from the car and use it as a stand-alone tent.

During the year, we acquired Reacha, a company that specializes in transporting kayaks and surfboards on bike trailers.

### SHARE OF THULE GROUP'S SALES:

# 59%

### MARKET POSITION:

Global market leader in roof boxes, roof racks and bike carriers. Niche growth player in rooftop tents.

### PRODUCT NEWS 2024:

**Thule ReVert**  
New bike carrier that can transport six bikes vertically.

**Thule Motion 3**  
The world's bestselling roof box with upgraded aerodynamics.

**Thule Outset**  
The world's first tent for the tow bar.

**Thule Caprock**  
Roof platform





## Thule Motion 3 – improved aerodynamics

Thule Motion is the world's bestselling roof box, probably because it offers the perfect combination of space, efficiency and style. The new version, Thule Motion 3, has an upgraded design and offers a wider range of sizes. Thule Motion 3's new low-profile variations improve fuel efficiency without compromising on storage capacity.



reddot-winner 2024



Thule Residence G3, Thule Velo Track, Thule Wanderway, Thule Chasm

## RV Products: Strong position but challenges for RV manufacturers

In RV Products, we are focusing on the European market, which accounts for 97 percent of Thule’s sales in this category. We are market leaders in terms of awnings and bike carriers for recreational vehicles (RV) and caravans, and we have an attractive product portfolio that also offers windbreaks and awnings for both types of vehicles.

In terms of RVs, Thule has two market channels – manufacturers of RVs and caravans, and retailers of RV products. Long-term relationships with vehicle manufacturers are crucial to remaining the supplier of choice and in many cases, our products are mounted as original equipment on vehicles.

One trend that has impacted the industry is the increased sale of smaller RVs. They are often used both for everyday and for outdoor activities, and clearly appeal to a new, often younger, target group. The trend also increases the demand for bike carriers for RVs/caravans, because it is an active target group.

In 2024, vehicle manufacturers reduced their production of RVs due to high inventory levels.

RV products are to a lesser extent sold directly to consumers online, as a lot of information is required about the vehicle the product is to be mounted on. During the year, we launched several products in the RV and camper van categories, which have been well received in the market.

Thule Sidehill is the most compact spring-loaded awning arm in the market and is designed for use in all types of compact vans. One of its features is that it allows for a minivan to stay under two meters in height so they still fit in garages.

Thule VeloTrack is a bike carrier for RVs with a high load capacity and allows for the loading of e-bikes that weigh significantly more than traditional bikes. Its design allows for the trunk to be opened even when the bikes are loaded.

Thule VeloSwing is a bike carrier that can also be used to pull a heavy trailer or box. Thule VeloSwing gets its name from the fact that it can be swung to the side, giving you full access to the back of the car even with the bikes loaded onto it.

### SHARE OF THULE GROUP’S SALES:

# 18%

### MARKET POSITION:

Market leader in awnings and bike carriers in Europe.  
Niche player in North America in the segment for smaller campers.

### PRODUCT NEWS 2024:

**Thule Sidehill**  
Most compact awnings for minivans.

**Thule VeloTrack**  
Bike carrier with high load capacity for e-bikes.

**Thule VeloSwing**  
Award-winning bike carrier and tow bar that can be swung to the side.



reddot winner 2024

## Thule VeloSwing wins award for its innovation excellence

With the Thule VeloSwing, you can mount the same bike carrier for tow bars as on your regular car to transport e-bikes, for example. Thule VeloSwing can be swung to the side for full access to the rear door, even with the bikes loaded. Thule VeloSwing's towing capacity is as high as the vehicle's limit, allowing for it to be used for pulling a heavy trailer or cargo box. Thule VeloSwing received the European Innovation Award under the Vehicle Equipment category, which is a coveted distinction for manufacturers and suppliers of RVs, vans, caravans and accessories.



red dot winner 2024



As of 2025, this category will be renamed "Active with Kids & Dogs."

## Juvenile & Pet: New product categories added

Juvenile & Pet has expanded with new product categories during the year. We are currently the international market leader in the premium segment for bicycle trailers and all-terrain strollers for children, and one of the three leading companies in child bike seats. In 2024, we took the step to expand into car seats and dog transportation because our customers want to be able to take their children and pets with them on their adventures.

The interest in commuting by bike combined with major investments in urban infrastructure and increased sales of e-bikes has strengthened the demand for solutions for transporting children and pets by bike. Thule is already the market leader in bicycle trailers for children and expanded its range during the year to include bicycle trailers for dogs, which can be sold through the same channels.

There is a continuing trend to live an active outdoor life together with the family; by extending our offering to families from transportation of their children in Thule's all-terrain strollers to a safe and high-quality child seats for cars, we have opened up another product segment.

Juvenile & Pet products are mainly sold through retailers, but the share of online direct-to-consumer sales has increased. Our aim is to maintain a high proportion of retailers going forward, because

parents often appreciate the expertise of a retailer. Thule Urban Glide is one of the world's most sold strollers, suitable both for city and for all-terrain use. A four-wheeled version with an improved seat and leg support has been launched.

We launched a new version of our bestselling bike trailer, Thule Chariot, which makes it easier to switch between cycling and walking. It also features a new modular seating system that makes it easy to switch from a center seat to two seats.

Thule Allax is a cleverly designed carrier for cars that meets the most stringent safety requirements. In addition, the bike trailer range has been extended with the Thule Bexey, a bike trailer for dogs.

Our Thule Maple car seat and Thule Alfi ISOFIX base exceeded all expectations when they were rated best in test in Europe's leading car seat test conducted by ADAC and Stiftung Warentest. The test covered crash safety, ergonomics and user-friendliness. The launch of this new category has gotten off to a good start and is now available in 26 European countries.

With the broadened range and this year's double-digit prestigious design awards in this category, Thule is becoming a well-known global brand in the premium segment of transportation products for children and dogs.

### SHARE OF THULE GROUP'S SALES:

# 13%

### MARKET POSITION:

Global market leader in premium products for bicycle trailers and all-terrain strollers for children. New player in car seats and dog transportation products.

### PRODUCT NEWS 2024:

**Thule Urban Glide**  
The third generation of the world's bestselling all-terrain stroller now comes with improved seat and leg support. In addition, it was launched in a four-wheel version.



**Thule Maple & Thule Elm**  
Child car seats for children from 6 months to 4 years. Thule Maple has a rotatable base that makes it easy to click in and out of the car seat.



**Thule Chariot Sports Double**  
The best cycling and jogging stroller on the market with a new seating system and easier switching between activities.



**Thule Bexey**  
Thule's first dog trailer where we have applied our knowledge in safety, quality and comfort to create the best experience for dog and owner.



**Thule Allax**  
Dog transport crates for cars in several different sizes with patented safety. Stylish aesthetic expression that breathes Thule.



## Thule Maple, Elm and Alfi – safety starts on installation

Our new range of car seats focuses on safety, ease of use and comfort. EasyDock technology makes it easy to install and rotate the car seats on the Thule Alfi ISOFIX base and our digital SenseAffirm display provides instant visual confirmation of correct installation. The Thule Impact Protection System and robust safety harnesses ensure that your child is protected.



reddot winner 2024



Thule Chasm

## Packs, Bags & Luggage: Increased travel and outdoor activities are driving this category

We offer a wide range of products within the category, Packs, Bags & Luggage; everything from the waterproof backpack for cycling to work, the durable and weather-resistant duffel bag for the weekend trip or the smart cabin bag for the business traveler. The luggage and bag industry is highly fragmented with geographically limited brands and a few strong global players, usually with a broad product range that encompasses several categories.

Thule's range of bags has changed and evolved over many years. In recent years, bags suitable for the activities covered by the other product categories have shown growth, such as backpacks for commuting to work, duffel bags for travel, and sports bags for hiking and winter sports. Accessories such as packing cubes and smaller day bags, including totes, slings and crossbody bags have also performed well. Bags under the Thule brand have increased in sales, while our range of so-called "legacy bags", primarily focused on electronics, has decreased.

The market is driven by increased interest in outdoor pursuits and travel as well as by growing demand for sustainable materials. Bags are well suited to selling online and the share of direct-to-consumer sales has grown steadily in the past few years.

In 2024, we launched upgraded versions of two of our major bag collections.

Thule Subterra 2 focuses on users who are in constant motion. With a modular system of bags that fit together and smart features such as adjustable interiors, you can find the right combination for every trip.

Thule Chasm features robust weatherproof duffel bags and sports bags that were launched in new colors and with more sustainable materials.

As of 2025, this category will be renamed "Bags & Mounts." Products added through the Quad Lock acquisition will also be included in the category.

### SHARE OF THULE GROUP'S SALES:

# 10%

### MARKET POSITION:

Stable, growing niche position in selected segments of everyday backpacks, carry-on cases, sports bags and small packing and organizational accessories.

### PRODUCT NEWS 2024:

**Thule Subterra 2**  
New sustainable and certified materials with new features and additional models.

**Thule Chasm**  
Duffel bags and sports bags made of recycled fabric in new colors.

**Thule Alltrail**  
Updated hiking and hydration backpack.

## Thule Subterra 2 – upgraded bluesign® certified collection

The second-generation Thule Subterra 2 comes in new colors, offers more smart features and products, and is made from bluesign® certified materials. bluesign® is an internationally recognized organization that only certifies textiles that meet their strict criteria for the protection of workers and the environment.



# Region Europe & Rest of World

The region's largest markets are in Central, Western and Northern Europe, with growth occurring in East-Central Europe and Asia. Our products are sold through in-store and online retailers, and in 15 countries through our own online sales at thule.com as well as through Thule's retail stores. We have six assembly sites in the region that are strategically located near our major markets.

The region accounts for 74 percent of Thule's sales and a full 97 percent of Thule's sales in the RV Products category.

## INCREASED SALES OF BIKE-RELATED PRODUCTS AND TWO NEW SUBCATEGORIES

In Region Europe & RoW, the organic growth was 4.7 percent. During the year, sales increased in three out of four product categories – Sport & Cargo Carriers and Juvenile & Pet. Sales of Packs,

Bags & Luggage was unchanged. Bike-related products were the main contributors to growth, while RV sales declined due to challenges in the market for new vehicle sales.

Several new product launches took place and two new categories – dog products and car seats – were introduced during the year.

In Europe, the expansion of direct-to-consumer (DTC) sales continued, generating growth in all product categories. Own sales via thule.com were launched in five new markets – the Czech Republic, Poland, Finland, Ireland and Portugal. Thule now conducts online sales for 15 European markets via thule.com. During the year, a Thule store was also opened in Munich, Germany. In total, DTC accounted for just over 5 percent of sales in the region.



Thule Urban Glide 4-wheel, Thule Chasm

### SHARE OF TOTAL SALES

SEKm	2024	2023
Sweden	335	327
Other Nordic countries	330	283
Germany	2,468	2,470
Other Europe	3,534	3,237
Asia/Pacific Rim	355	326
Rest of World	50	46
<b>Total</b>	<b>7,072</b>	<b>6,682</b>

### PERCENTAGE OF SALES

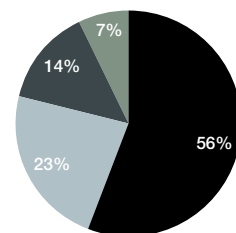

- Sport&Cargo Carriers
- RV Products
- Juvenile & Pet
- Packs, Bags & Luggage

### SALES BY PRODUCT CATEGORY

SEKm	2024	2023	2022	2021	2020
Region Europe & RoW	7,072	6,682	7,091	7,440	5,721
Sport&Cargo Carriers*	3,973	3,667	4,090	4,694	3,496
RV Products	1,653	1,720	1,700	1,403	1,117
Juvenile & Pet	964	884	887	1,024	793
Packs, Bags & Luggage	482	412	415	320	315

\* Includes other revenue, primarily pertaining to development work conducted for external customers.

As of 2025, Region Europe & RoW will be split up. Sales in Europe will be reported under Region Europe. Asia will be included in RoW together with Central and South America.



## Sport&Cargo Carriers

Thule's roof racks and roof boxes are part of a global range, with most of the models being offered in Europe and Asia. The sizes and models in demand vary depending on what is being transported. In areas with snow, the transportation of skis is common, while in warmer latitudes, roof boxes have a wider range of uses.

Bike carriers have a large geographical spread in Europe, with widespread use of the tow bar for loading. In Asia, the legislation differs between countries and heavier loads on the towbar are not always permitted.

Rooftop tents are on the rise in Europe, where there are good facilities for camping. They are an attractive alternative to investing in an RV.

Change in sales from 2023: +8%



## RV Products

As much as 97 percent of RV Products' sales are made in Europe. There is a strong tradition of going on vacation with your RV or camper van and customers are willing to pay for premium products to enhance their experience.

Change in sales from 2023: -4%



## Juvenile & Pet

Bicycle trailers have a strong position in Europe. Their popularity varies between countries depending on the level of cycling infrastructure. In Asia, cycling is widespread but transporting children is not as common due to the traffic environment.

Thule's jogging and all-terrain strollers have a strong position in Europe and account for a smaller share of sales in Asia.

During the year, we launched dog transportation products and added car seats as a new product category. Car seats were launched only in Europe, unlike dog products, which were launched in all regions.

Change in sales from 2023: +9%



Thule Bëxey



Thule Easy Fold 3



## Packs, Bags & Luggage

Increased travel and newly launched models are contributing to the popularity of Thule's bags. Thule's bags derive a large share of their sales from Asia.

As expected, sales within categories linked to consumer electronics, such as camera bags and tablet cases continued to decline.

Change in sales from 2023: 0% (excluding Quad Lock).

The category growth numbers are currency adjusted.

# Region Americas

The region is divided into North, South and Central America. It offers wide variations in active living both at national and at regional levels. The US is the region's largest market, while Canada has the highest per capita sales. Central and South America are geographically vast markets, with several South American countries mainly active in cycling and water sports. Our products are mainly sold through retailers – in stores and online. In the US, Canada and Brazil, our products are sold online through thule.com and in several countries, through Thule's own stores. We have three proprietary assembly sites in the region – two in the north and one in the south.

## CONTINUED NEGATIVE MARKET IMPACTING RESULTS

Region Americas accounts for 26 percent of Thule's sales. In Region Americas, organic growth was 0.1 percent in 2024. Sales declined in the categories: Sport & Cargo Carriers; Packs, Bags & Luggage; and RV Products. Sales increased in the

Juvenile & Pet category, where we launched a number of new products and a new category of dog products. Sales of bike-related products developed positively during the year despite a negative market trend, mainly due to the successful launch of new products.

Sales in North America declined due to a more challenging market, particularly in the US, while sales in Canada, and Central and South America developed positively during the year, despite the tougher market conditions also in this market.

Market conditions contributed to a negative trend of minus 3 percent in direct-to-consumer (DTC) sales during the year. In total, DTC sales accounted for 16 percent of sales in the region during the year.



Thule Motion 3, Thule WingBar Edge, Thule GoPack duffel set

## SHARE OF TOTAL SALES

SEKm	2024	2023
USA	1,849	1,847
Other North America	440	415
Central/South America	180	181
<b>Total</b>	<b>2,469</b>	<b>2,450</b>

## PERCENTAGE OF SALES

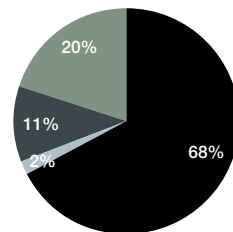

- Sport&Cargo Carriers
- RV Products
- Juvenile & Pet
- Packs, Bags & Luggage

## SALES BY PRODUCT CATEGORY

SEKm	2024	2023	2022	2021	2020
Region Americas	2,469	2,450	3,047	2,946	2,107
Sport&Cargo Carriers	1,670	1,695	2,129	2,227	1,540
RV Products	55	52	155	101	49
Juvenile & Pet	262	232	259	265	195
Packs, Bags & Luggage	482	471	504	354	323

As of 2025, Region Americas will be split up. Sales in North America will be reported under Region North America. Central and South America will be included in the RoW region along with Asia.



## Sport&Cargo Carriers

Thule's roof racks and roof boxes are part of a global range, with most of the models being offered in North, Central and South America. The sizes and models in demand vary depending on what is being transported. Near the coast and in the warmer parts of the Americas, it is common to use roof boxes for transporting surfboards and other items associated with beach life.

Bike carriers have a particularly strong foothold in North America, where a differently designed towing device called a "hitch" allows for bike carriers to handle higher loads than in Europe. The vehicle types are also different from Europe and Thule offers several models of bike carriers specially adapted for the American market. In Central and South America, the transportation of bikes is not as popular.

Rooftop tents are widely used in North America, where they are well suited to an infrastructure that features the car as a big part of the camping experience.

Change in sales from 2023: -1%



## RV Products

RV sales account for only 3 percent of Thule's sales in the region. We chose to have a niche product offering focused on smaller vehicles for active people.

Change in sales from 2023: +7%



## Juvenile & Pet

Bicycle trailers are not as widely used in the Americas compared with Europe. In North America, however, interest is growing as bike infrastructure improves.

Thule Urban Glide has a strong position as a popular jogging and all-terrain trailer in North America. In Central and South America, the market for this type of stroller is smaller.

During the year, we launched several dog transportation products. Our launch activities have focused, among other things, on building awareness of and knowledge about how dogs can be transported more safely and comfortably.

Change in sales from 2023: +14%



Thule Urban Glide 3 with bassinet



Thule Chasm



## Packs, Bags & Luggage

Increased travel and newly launched models have contributed to the popularity of Thule's bags.

Historically, the region has had greater exposure than Europe in terms of categories linked to consumer electronics, such as camera bags and tablet cases.

Change in sales from 2023: -5% (excluding Quad Lock)

The category growth numbers are currency adjusted.

PUSHING THE ENVELOPE WITH PRODUCT DEVELOPMENT

# Setting our sights on the horizon

**At Thule, we work innovatively and methodically with product development in all categories, which is resulting in sustainable growth and consolidating our position as a premium brand. Our goal is to ensure that everyone who chooses our products has an experience of safety, quality and sustainability – a combination that defines Thule. Every product is rigorously tested before it reaches the market, after which we continue to work tirelessly to challenge and improve our solutions.**

We have long been active participants in industry forums that are responsible for setting global standards and guidelines. Our development process is a key driver of profitable growth and is based on a structured and continuous process. Even after launch, we conduct regular tests to maintain the high product quality that our customers expect. In 2024, we invested a total of SEK 671 million (629) in product development, corresponding to 7.0 percent (6.9) of Group sales.

**STAYING ONE STEP AHEAD**

Our employees, who are often active users of our products, are strongly committed to identifying areas for improvement and creating smart solutions. This commitment allows us to adapt quickly to new requirements and trends.

We actively participate in working groups that shape guidelines and standards for future product categories. This provides us with insight into the requirements of the 138 markets where we are active. We also work closely with leading manufacturers in the automotive industry and outdoor sectors – from bikes and kayaks to skis and RVs. This generates valuable knowledge and information to the requirement specifications of the next big product success. In addition to tracking industry developments, we value our close collaboration with consumers who provide us with insights and ideas for future designs. To this we add our own climate targets, measured through rigorous life-cycle assessments\*.

Thule has a hands-on product development philosophy and, in addition to our solid internal expertise and advanced test equipment, we attach great importance to the early production of prototypes that are then used actively in real life. Virtual simulations are complemented by physical testing to provide direct and comprehensive feedback at every stage of the development process. All of these insights have a considerable impact on the design of the final products.

**THE RED DOT DESIGN TEAM OF THE YEAR IS LOCATED IN HILLERSTORP**

In 2024, Thule’s design team was awarded the Red Dot Design Team of the Year, a prestigious award given since 1988 to brands that demonstrate exceptional quality and innovation. Thule is the second Swedish company ever to receive this award. We are extremely proud to join the ranks of winners, which include well-known brands such as Apple, Porsche, Ferrari and Sony.

**A DESIGN MINDSET FOR LONG SERVICE LIFE**

Our products are built to last for many years and to withstand tough daily use. We know that our customers appreciate responsibly made products that they can rely on for a long time. That’s why our design language is timelessly modern and developed to facilitate repair, replacement of worn parts and resale in a secondhand market.

\*Life cycle assessment is a method of measuring the total environmental impact of a product, from raw materials to final recycling.





## Thule Outset – for quick getaways

Mounting the Thule Outset on a tow bar is easy and, once done, it only takes a couple of minutes to set up the tent. With panoramic views and a spacious interior, the tent is a comfortable place to rest and is elevated off the ground. It also features durable, weatherproof construction and a soft mattress. Rigorous rain and wind-chamber tests, as well as collision tests ensure a high level of safety. In addition, the aerodynamic positioning of the tent behind the car entails less impact on fuel economy or battery range and frees up space on the roof.

### PATENTS AND INNOVATION

We use structured development processes to secure that manufacturing is efficient and sustainable, and most of all, to achieve our ambitious targets for user-friendliness and safety. Over the years, we have proven our ability to create technical solutions that make life easier for the user. One of our most recent examples is the patented solution for our Thule Arcos tow bar mounted cargo box, which reduces the car's fuel consumption and allows you to access the cargo box without having to reach for the roof.

### STRINGENT TESTS CREATE CONFIDENCE AMONG CUSTOMERS

Safety, quality and functionality are the cornerstones of Thule's products. Rigorous tests are performed through our Thule Test Program™. At our Global Test Center in Hillerstorp, we test everything from crash safety and shaking to extreme weather in state-of-the-art facilities. This is particularly important for advanced product categories such as car seats and dog crates, where safety is paramount.



The birth of innovation is usually sparked by inspiration. For Thule Outset that spark was a desire to develop a completely new camping solution. We wanted to create a whole new way of camping, something that transforms an everyday vehicle into a luxury adventure vehicle. At Thule, design is not just about aesthetics; it is about creating practical, strong and reliable products. Thule's design language involves strong shapes and sharp transitions. Consequently, the tent's design features accentuated edges and its articulated shapes communicate both strength and softness."

**Henrik Eriksson**, Global Design Director at Thule

MANUFACTURING AND LOGISTICS

# Own manufacturing close to the market

**We have chosen to own all the rights to the products we develop. With our clear focus and stringent requirements on eco-design, materials know-how and quality, we have developed deep and reliable expertise in manufacturing over the years.**

The decision on where, how and by whom a product is to be manufactured is based on pragmatic, long-term reasoning based on when it is most logical to conduct the manufacturing inhouse and when it should be outsourced. Factors that influence such decisions include quality assurance, resource management, climate impact and the protection of intellectual property rights. The Group currently has nine well-invested modern manufacturing sites located in or near our large markets.

**A STRONG GLOBAL SUPPLIER BASE**

We have worked closely with our suppliers for many years to ensure increased efficiency, reduced emissions and constant improvements. High on the agenda are safe and secure workplaces, a conscious choice of materials (increased amounts of recycled materials and/or easily recyclable materials), energy-efficient manufacturing methods, and optimized transport and packaging solutions.

**FLEXIBLE STAFFING MODEL**

Our structure, with our own assembly plants and a flexible staffing model, in and close to our most important markets remains a huge competitive advantage.

This flexibility was required, since most of our key products have large seasonal volume fluctuations. Accordingly, in our own assembly plants, we have three staffing levels with full-time personnel as

the base, supplemented by seasonally employed in-house personnel and short-term personnel from external staffing companies for the absolute peaks.

**INVESTMENTS FOR THE FUTURE**

To ensure that we can meet future increases in demand, we make continuous investments to improve our production and supply chain. In 2024, we invested a total of SEK 288 million (269), corresponding to 3.0 percent (2.9) of sales.

For example, one of the investments was in our production facility in Poland, where we installed 30 air-to-air heat pumps in 2024. They are three times more efficient than traditional heat pumps and are powered by green electricity. From previously accounting for 7 percent of the Group's scope 1 CO<sub>2</sub> emissions, the factory's emissions have gone down to zero.

**FLEXIBLE SUPPLY CHAIN FOR SUSTAINABLE GROWTH**

Logistics comprises a strategically important issue, due to Thule's global sales structure, growing production capacity, partnerships with some 750 materials suppliers in 32 countries, our high rate of innovation with product launches in new categories, and growing e-commerce combined with a Net-Zero carbon strategy. It is also important for meeting customer expectations in terms of climate-smart and cost-efficient deliveries, and for

Category	Production strategy
<b>Sport&amp;Cargo Carriers</b>	Mainly in-house assembly with limited sourcing of finished goods
<b>RV Products</b>	Mainly in-house assembly with limited sourcing of finished goods
<b>Juvenile &amp; Pet</b>	Combination of in-house assembly and sourcing of finished goods
<b>Packs, Bags &amp; Luggage</b>	Mainly sourcing of finished goods



achieving our own ambitious climate and development goals. At the same time, we are noting a trend for retailers to reduce their shared inventories and for more direct deliveries to be made to each individual store, which changes the conditions.

**EFFICIENT TRANSPORT**

Through strong partnerships and close dialog with our partners, we ensure that our entire supply chain meets national and international guidelines as well as our own Code of Conduct. Our focus is on optimizing transport by increasing capacity utilization, minimizing air freight and replacing road transport with rail transport where possible.

To make informed decisions, we have introduced more detailed reporting to let data guide us to wiser decisions. Some of our priority initiatives include:

**Reducing air freight:** We are replacing air freight with road and sea transport where possible. This work has contributed to a reduction of our carbon emissions by over 36 percent between 2019 and 2024, from 3,163 tons of CO<sub>2</sub>eq to 2,038 tons CO<sub>2</sub>eq.

**Consolidated deliveries:** By consolidating and optimizing deliveries, we can reduce the number of shipments and thereby, our environmental impact.

**Last-mile transportation:** We are continuously exploring new and more sustainable solutions for last-mile deliveries to customers and for local transportation. For example, in 2024 we introduced two biogas-powered delivery trucks for local deliveries in proximity to our factory in Hillerstorp.



For in-depth information about greenhouse gas emissions linked to our logistics solutions, see page 44.

# Sustainability Report

# Sustainability statement

## We only have one strategy – and it is sustainable

Our strategy is based on creating long-term value through consumer-driven innovation, proven material and manufacturing competence, financial strength and a strong focus on environmental, social and ethical matters throughout the entire value chain.



Thule Chariot Sport

**Sustainalytics**  
Rated among the top 50 companies globally by Morningstar Sustainalytics.

**Ecovadis**  
Top 1 percent of 65,000 companies in 160 countries.

**Science Based Targets Initiative**  
Net-Zero emissions 2050, scopes 1, 2 & 3.

**Carbon Disclosure Project (CDP)**  
178 suppliers participated.

## A passion to push boundaries

Our origins lie in the dense forests of southern Sweden. We are a team of diligent creators and engineers who measure everything we do, with the intention to always push boundaries, find smarter solutions and lower our carbon footprint. New knowledge breeds new ideas. By 2030 we will have an entirely new product portfolio. And by 2040 we will have reinvented ourselves – again. All to inspire people to live active lives.

Our work is guided by the principles of the U.N Sustainable Development Goals, our Code of Conduct and Sustainability Policy, that are well integrated into our strategic, as well as daily work throughout the entire value chain.

**We have committed to** the Science Based Targets Initiative (SBTi), and have approved targets in line with the Paris Agreement and the long-term Net-Zero emissions target. Continuous improvements are the basis of our efforts, and in all our development we have high ambitions and innovative ability.

**We have a deep respect** for the impact of our products and operations, on the environment and climate. Our consumers trust that our products are safe and durable, and we strive for transparency regarding how they are manufactured, which organizations like Ecovadis attest to.

**According to Ecovadis**, Thule Group is among the top 1 percent of the 65,000 companies in the 160 countries reviewed. And Morningstar Sustainalytics has rated us among the top 50 companies globally out of 15,000 companies reviewed. These recognitions reflects our dedication to integrating environmental, social and governance principles in all aspects of our operations.

**All employees and workers** in our value chain have the right to perform their work in a safe and secure environment. Annually, we evaluate suppliers and subcontractors (tier 1 and 2) to ensure healthy working conditions, that no

violations of human rights occur, and that high ethical levels, and environmental requirements are met.

**Shareholders looking for** sustainable investments can rely on Thule Group being a good choice. Our inclusion in both the Dow Jones Sustainability Index and the Nasdaq OMX Sweden Small Cap 30 ESG Responsible Index™ are a testament to our commitments.



For more information about external assessments of our sustainability agenda, refer to pages 135.

# General disclosures

**Thule Group is presenting its sustainability information for 2024 in a format inspired by the current interpretation of the European Sustainability Reporting Standards (ESRS). The report has been prepared in accordance with the Swedish Annual Accounts Act.**

Thule Group is preparing for future assurance in accordance with ESRS. The transition to CSRD is a major undertaking; implementing some of the requirements already at this stage enables a more mature and transparent report to be presented in the coming years. For more information about the basis for preparation view page 38.

### SUMMARY MATERIAL MATTERS

Our largest positive impact is in mitigating climate change through the use of renewable energy at our manufacturing sites, optimizing shipments, and reducing the carbon footprint of our product categories. We also review our suppliers' sustainability performance in order to limit climate impact, and highlight the importance of human rights. We conduct trainings on our Code of Conduct, to increase knowledge and requirements for development. We work actively to increase the share of low emission, and recycled materials, and to ensure that our own products can be reused, and recycled, thereby increasing circularity.

### Our largest negative impact

We contribute to climate change through the GHG emissions caused by our shipments, business trips, purchased heat/cooling, electricity and purchased goods and services.

### EXAMPLE OF MATERIAL MATTERS

#### Our impact on the environment

Reduced emissions from our products and from our own operations.

#### The health and safety of our employees

Focus on reducing the number accidents at work. No discrimination. Gender equality in salaries and conditions.

#### Product safety

Child safety is a prioritized material matter. The likelihood of a negative impact is low, but the severity is high.

#### Suppliers

Work conditions at our suppliers.

### STATEMENT ON DUE DILIGENCE

Core elements of due diligence	Pages in the sustainability statement
Embedded due diligence in governance, strategy and business model	37-38, 70-71
Engaging with affected stakeholders in all key steps of the due diligence	38, 66-67, 70-71
Identifying and assessing adverse impacts	38, 46-49, 76-82
Taking actions to address those adverse impacts	40, 46-49
Tracking the effectiveness of these efforts and communicating	43-45, 54-56, 61-63, 71

### DISCLOSURES INCORPORATED BY REFERENCE

	Pages in the sustainability statement
ESRS 2 GOV-1 paragraph 21(d)	70-71, 84-89
Disclosure requirement SBM-1 paragraphs 40(a)-(c), 42(a)-(b) – Strategy, business model and value chain	37-38, 70-71
Disclosure requirement GOV-3 – Integration of sustainability-related performance in incentive schemes (in Financial Notes)	108
Risk management and internal control over sustainability reporting	38, 70-71
Important governing documents	69

# Our value chain

## SUSTAINABLE GROWTH PERMEATES THE ENTIRE VALUE CHAIN

A sustainable supply chain and cost-efficient, climate-smart distribution is high on our agenda. Thule Group has approximately 750 material suppliers in 32 countries – its own manufacturing at nine facilities in seven countries, and sales to more than 30,000 retailers in 138 markets. Through partnerships and close dialogues, we ensure that our entire value chain meets national and international regulations and guidelines, as well as our Code of Conduct, which sets high requirements.

## THULE GROUP HAS A STRONG SUPPLIER BASE AROUND THE WORLD

We have worked closely with our suppliers for many years to ensure increased efficiency and continuous improvements. Together we promote safe and secure workplaces and reduce emissions along the entire value chain.



### ◀ Recycling

- Product design that makes recycling easy

### Product development ▶

- Energy efficiency
- Carbon-efficient solutions
- Focus on safety and quality
- Eco-design and product environmental footprint

### ◀ Sourcing

- Partnership
- Transparency
- Review
- Sustainability

### Customer experience ▶

- Partnership
- Transparency
- Service and education

### ◀ Use

- Safe, user-friendly products
- Products with long lifetimes
- Spare parts, repair services and instructions to extend product life

### ◀ Own manufacturing

- Ensure health and safety
- Attract, develop and retain talent
- Sustainable and efficient production

### ◀ Transportation

- Optimize packaging
- High share of assembly close to markets
- Sustainable modes of transport

# Our responsibility and impact throughout the value chain

OUR IMPACT	OUR APPROACH	HOW WE MAKE A DIFFERENCE
<b>Product development</b> Degree of influence: <b>HIGH</b>		
Carbon-efficient solutions, focus on product safety and quality, and on smart use of materials are central priorities. In 2024, we invested SEK 662m in sustainable product development.	Design products based on a life cycle perspective – we calculate the life cycle impact of the product from the cradle-to gate, design products for recyclability, durability, and provide spare parts and repair services to extend the product’s life cycle. Our products also undergo state-of the art testing to ensure high quality, and long-lasting life of the product.	By driving the development of products with lower carbon emissions and through innovations in safety and material use, we strengthen our competitive ability and reduce both waste and energy use and increase product safety and functionality.
<b>Sourcing</b> Degree of influence: <b>HIGH</b>		
Thule purchases raw materials and components from approximately 750 suppliers in 32 countries. We work continuously to choose the best suppliers to support our strategy of driving change and reducing risks in the supply chain. In 2024, we purchased SEK 528m of low emission and recycled materials.	<ul style="list-style-type: none"> <li>▶ Run our operations according to best business practices and a high ethical standard and ensuring compliance with our Code of Conduct and Supplier Code of Conduct.</li> <li>▶ Conduct regular audits and focus on sustainability.</li> <li>▶ Encourage our suppliers to be innovative and share their good examples.</li> <li>▶ High-quality, high-performance materials with low GHG emissions.</li> </ul>	Partnership with our suppliers helps us achieve our sustainability goals, and in parallel allows us to develop better products and drive cost savings. We encourage our suppliers to work with the same sustainability goals that we have, which helps us reduce negative effects and increase transparency in the supply chain.
<b>Own manufacturing</b> Degree of influence: <b>HIGH</b>		
Thule has nine manufacturing sites in seven countries. Our sustainability agenda includes social, economic and environmental impact and our actions affect all parts of the value chain. Our direct GHG emissions account for a relatively small portion of our total climate impact and come primarily from energy use in our assembly plants.	<ul style="list-style-type: none"> <li>▶ Strive to always conduct business according to ethical business methods and follow our Code of Conduct and Sustainability Policy and Health and Safety Policy.</li> <li>▶ Ensure health, safety and well-being.</li> <li>▶ Attract, develop and retain the best talent in all portions of operations.</li> <li>▶ Focus on always conducting operations sustainably and efficiently.</li> </ul>	Our employees receive competitive remuneration, skills training and are offered career opportunities at the same time as society benefits from jobs and tax income. Efficient production close to our main markets means both reduced costs and lower climate impact.
<b>Transportation</b> Degree of influence: <b>MEDIUM</b>		
Approximately 7 percent of our carbon emissions come from transportation, both upstream from our suppliers and downstream to our customers and consumers. Choice of packaging, co-loading and the length and method of transportation affect our carbon emissions positively or negatively.	<ul style="list-style-type: none"> <li>▶ Reduce the share of air freight.</li> <li>▶ Improve efficiency in the logistics chain.</li> <li>▶ Optimize product packaging.</li> <li>▶ Increase share of product assembly close to the market.</li> <li>▶ Use more sustainable transportation methods for the last mile to the customer.</li> </ul>	The ambition to increase the share of sustainable transportation and reduce the share of air freight is an important part of our effort to contribute to society’s shared ambition to reduce carbon dioxide emissions. Optimizing logistics also effects our long-term financial sustainability.

OUR IMPACT	OUR APPROACH	HOW WE MAKE A DIFFERENCE
<b>Customer experience</b> Degree of influence: <b>MEDIUM</b>		
We sell our products in more than 30,000 retailers in 138 markets, in physical stores and online. We strive to promote and increase the sales of the most sustainable products, and provide alternatives when it applies to safety, climate and environmental impact.	<ul style="list-style-type: none"> <li>▶ Emphasize advantages of our most sustainable products.</li> <li>▶ Provide tools and marketing methods that can be adapted for local use all over the world.</li> <li>▶ Provide spare parts and instructions about how consumers can extend the lifetime of the product.</li> </ul>	Through our transparency about the climate, environmental and social impact of our products, we help our customers and retailers meet consumer expectations.
<b>Use</b> Degree of influence: <b>LOW</b>		
Since a large portion of our sales come from products that are used on vehicles, a significant portion of our climate impact arises during use. Our ability to reduce this impact is entirely dependent on our knowledge of product design and ability to ensure that the right material is chosen. The aspects are central for being able to meet our stringent requirements and standards for safety in the most sustainable manner. It is also important for the product to be easily mounted on and off.	<ul style="list-style-type: none"> <li>▶ Ensure life cycle analyses based on actual use.</li> <li>▶ Develop products with low climate impact that meet the quality requirements for tough environments.</li> <li>▶ Provide spare parts, repair services and instructions about how consumers can extend the lifetime of the product.</li> </ul>	Ensure product solutions that increase personal safety, while product guarantees, spare parts and instructions extend the lifetime of the product.
<b>Recycling</b> Degree of influence: <b>LOW</b>		
When our products reach the end of their life cycle, material and components need to be recycled so they can begin a new cycle.	<ul style="list-style-type: none"> <li>▶ Design products for recyclability and integrating it as a component of product specifications and design work.</li> <li>▶ Ensure life cycle analyses based on actual use for all products.</li> <li>▶ Follow changes in laws and regulations as well as trends in material development.</li> <li>▶ Use more recyclable material in products.</li> <li>▶ Promote circular approaches in partnerships with other companies.</li> </ul>	Our products are largely manufactured out of aluminum, steel and plastic, which are all recyclable. We are investigating how we can use more recycled material while we meet our stringent safety requirements and standards. The goal is to reduce waste from our products and come closer to creating a circular value chain. We collaborate with industry organizations when it comes to using sustainable fabrics. Ease of disassembly is in focus as early as the design stage.

# Double materiality assessment

## Description of the processes to identify and assess material impacts, risks and opportunities.

In the context of conducting the double materiality analysis, a mapping of the activities in Thule’s value chain was carried out. This analysis delineates the activities occurring in Thule’s (1) upstream value chain, (2) own operations, and (3) downstream value chain. For the DMA conducted in 2024, we have considered impacts only from tier 1 of the upstream value chain. This allows us to establish a clear reporting boundary for 2024, enabling a more in-depth analysis of the business activities and impacts of our tier 1 suppliers, and will help us to delineate and map other impacts such as to water and biodiversity, to suppliers further upstream the value chain.

Each activity has been analyzed based on its geographical location, Thule’s business relationships related to the activity, the key resources utilized in the activity, and considering the stakeholders affected or potentially affected by the activity.

The purpose of the mapping was to gain an understanding of the activities in Thule’s value chain and thereby identify areas of impact, risk, and opportunity in the double materiality analysis.

### IDENTIFICATION OF IMPACTS, RISKS AND OPPORTUNITIES (IRO’S)

The process of double materiality analysis began with the identification of Thule’s actual and potential, positive and negative impacts on people and the environment in the short, medium, and long term.

In this process, all sustainability topics in ESRS 1 AR 16 were considered. In line with ESRS 1, the impact was identified based on aspects of whether

the company causes, contributes to, or is directly linked to impact through business relationships. The process was conducted for Thule’s own operations and the upstream and downstream value chain. Financial risks and opportunities in the short, medium, and long term were then identified in relation to the identified impacts.

Assumptions about impacts in the upstream and downstream value chain have been made in relation to certain sustainability matters. The reason for this is because information has not been directly collected from actors in the downstream and upstream value chain.

### THRESHOLDS

After impacts, risks, and opportunities were identified, these were assessed against materiality assessment criteria based on likelihood, scope, and irremediable character for negative impacts, and likelihood, scope and scale for positive impacts. For financial risks opportunities, the likelihood and financial magnitude was considered. The maximum value for materiality is 5, and the materiality threshold is 3. Consistently, all impacts, risks, and opportunities are classified as material if their final materiality value equals or exceeds 3.

### STAKEHOLDER DIALOGUE

Thule Group conducts the stakeholder dialogue every two years. In 2023, we engaged with our stakeholders, consisting of both affected stakeholders, and stakeholders that can affect Thule Group. The recipients included investors, board members, suppliers, customers, and other stakeholders.

The most important sustainability matters that were identified by stakeholders are climate change impacts, such as reducing GHG emissions, supply chain due diligence, and health and safety.

Internal stakeholders also highlighted human rights, logistics, and waste, as a key areas of focus. The clearest change from earlier surveys indicates that GHG emissions have become increasingly significant.

Our work with sustainability is aligned with the interests of the stakeholders, whereby we are making efforts to reduce GHG emissions in scope 1, and 3, as well as keep actively sourcing renewable electricity for all of our sites above 12 employees, for scope 2. In addition, we are making efforts to reduce emissions from purchased materials, and working with suppliers on getting supplier information on additional material matters.

The results from the stakeholder survey are shared with the Board and Group Management, whereby we ensure that Group level ESG targets are also aligned with the views of the stakeholders.

Since our initial double materiality assessment we conducted in 2023, we have refined the double materiality assessment, to establish our reporting boundary for 2024, and to align with our ESRS inspired reporting. A new stakeholder dialogue will be conducted in 2025 and all stakeholders will be updated on the sustainability matters that Thule will report on. Their interests and concerns will be taken into account when reviewing the double materiality assessment.

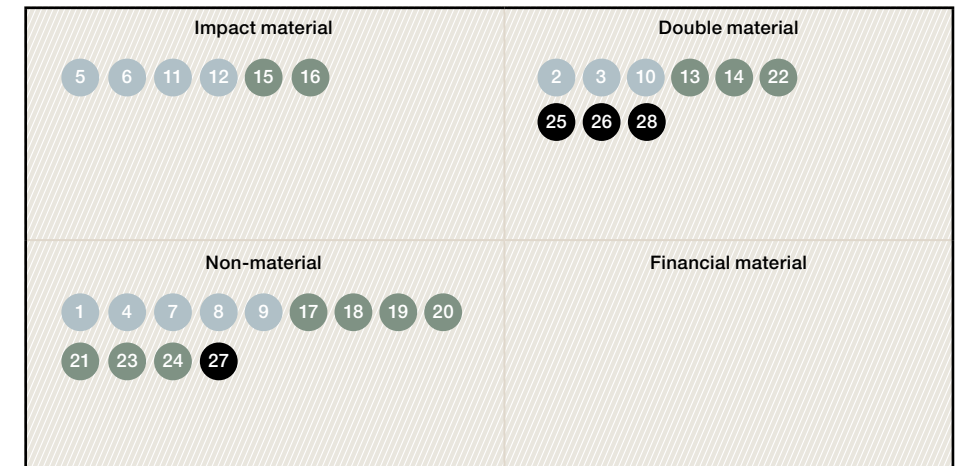

ESRS	Topic	No.	Sub-topic/Sub-sub-topic
E1	Climate change	1	Climate change adaptation
		2	Climate change mitigation
		3	Energy
E2	Pollution	4	Pollution of air, water, soil, living organisms and food resources
		5	Substances of concern
		6	Substances of very high concern
E3	Water and marine resources	7	Water consumption
E4	Biodiversity and ecosystems	8	Biodiversity – Climate change
		9	Biodiversity – Pollution
E5	Circular economy	10	Resource inflows
		11	Resource outflows
		12	Waste
S1	Own workforce	13	Working conditions
		14	Equal treatment and opportunities for all
		15	Other work-related rights
S2	Workers in the value chain	16	Working conditions
		17	Equal treatment and opportunities for all
		18	Other work-related rights
S3	Affected communities	19	Land-related impacts
		20	Cultural rights
S4	Consumers and end-users	21	Privacy
		22	Personal safety of consumers and/or end-users
		23	Non-discrimination
		24	Responsible marketing practices
G1	Business conduct	25	Corporate culture
		26	Protection of whistle-blowers
		27	Management of relationships with suppliers
		28	Corruption and bribery

# Environment



## Committed employees drive the development of Net-Zero

**We are driven by the highest standards of safety, function, and respect for the environment. We are curious and passionate entrepreneurs who believe that people have the power to move the world forward. At each product launch, we aim to reveal a glimpse of the future in each product category and always lower the climate footprint.**

### FOCUS AREAS

- ▶ Emission reduction aligned with the 2030 SBTi and Net-Zero target for 2050.
- ▶ Continue sourcing 100 percent renewable electricity at our plants and offices (scope 2).
- ▶ New products, with at least SEK 20 million in sales in their second year, must cut CO<sub>2</sub>eq emissions by at least 30 percent compared to a previous version.

STRATEGY

# Our decarbonization strategy

Our work throughout our value chain is characterized by high ambitions. The climate targets for 2030 are aligned with the Paris Agreement, and they are verified according to the science Based Targets Initiative (SBTi), along with our Net-Zero targets for 2050.

We are systematically moving towards fossil-free operations by adopting ambitious targets that are clear to everyone.

## Policies

- ▶ Sustainability Policy
- ▶ Supplier Code of Conduct
- ▶ Chemicals Policy
- ▶ Biodiversity Statement
- ▶ Human rights policy (takes into account environmental rights, soil and forest rights)

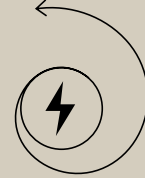

## Targets

### CLIMATE GOALS FOR THE 2030 AGENDA IN ACCORDANCE WITH THE SBTi:

- ▶ An absolute reduction of 46.2 percent in scope 1 emissions until 2030 compared to the 2019 base year.
- ▶ Continue the active sourcing of 100 percent renewable electricity at our facilities and offices with more than 12 employees until 2030.
- ▶ Reduce absolute emissions related to purchased materials, upstream and downstream transportation (scope 3) with 28 percent by 2030 compared to the 2019 base year.

### NET-ZERO 2050 IN ACCORDANCE WITH THE SBTi:

- ▶ Scope 1, 2 and 3 targets: 90 percent absolute reduction (compared with base year 2019) and 10 percent carbon offset.
- ▶ Reduce CO<sub>2</sub>eq emissions from product materials for all new products having more than second year revenue >20MSEK, compared to a benchmark product until 2030.
- ▶ Maintain a recycling rate of at least 98 percent, including hazardous waste.

## Day-to-day operations

Reduce direct and indirect emissions.

Integrate circular thinking in product design.

Extend product lifetime.

Increase the share of recycled materials.

Efficient consumption of resources/ minimizing waste.



Thule Outset

# EU Taxonomy

**In this section, information is provided on how the economic activities in the EU Taxonomy apply to Thule’s operations, including how the criteria for substantial contribution have been determined.**

## DESCRIPTION OF ELIGIBLE ACTIVITIES

Thule Group has a high ambition in terms of minimizing the environmental footprint of our products, and production processes. We want to ensure that our investments are aligned with key sustainability criteria, and that our growth is aligned with the principles of sustainable financing, where feasible. Our core business, which is consumer products for the sports and outdoor category, is not currently listed a main sector in the EU Taxonomy Compass. However, since 2021, we have been reporting on Sector 7 in the Construction Sector, for both CapEx and OpEx for eligible and aligned activities, as the turnover KPI was not applicable.

Similarly, for 2024, we are reporting on the CapEx and OpEx for climate change mitigation and adaptation for the following activities in Sector 7.

- 7.1 Construction of new buildings.
- 7.2 Renovation of existing buildings.
- 7.3 Installation maintenance and repair of energy efficiency equipment.
- 7.4 Installation maintenance and repair of charging stations for electric vehicles in buildings (and parking spaces attached to buildings).
- 7.5 Installation, maintenance and repair of instruments and devices for measuring, regulation and controlling energy performance of buildings.
- 7.6 Installation, maintenance and repair of renewable energy technologies.

In addition to Sector 7, in 2024, we have also included CapEx and OpEx for activities contributing to circular economy in Sector 2.2 Water supply, sewerage and waste management and remediation activities, due to the fact that we have maintenance work and investments in some of our sites that have rain water tanks, as well as Sector 2.3 Collection and transport of non-hazardous and hazardous waste. We are also reporting on activities contributing to Circular Economy in Sector 5: Other Services, whereby for the first time we can report on activities eligible/aligned with turnover.

## CAPEX

During previous years, Thule invested substantial amounts in our facilities in Poland and Sweden. In 2024, we have continued to invest in our sites, but at a lower pace. Despite this, we made a significant investment in our site in Pila, Poland, where we replaced gas boilers with electric heat pumps. This is also aligned with our Scope 1 decarbonization strategy for 2030. In total, Thule invested 363 MSEK in capital expenditures, whereas 29.98 MSEK is taxonomy eligible of which 29.82 MSEK is taxonomy aligned.

For calculation of the denominator related to the CapEx KPI amounts are calculated based on accounting records consistent with our accounting policies regarding CapEx (see Right-of-use assets and Tangible- and Intangible assets on pages 113–114 in our Annual Report 2024.

## OPEX

The Taxonomy regulations define OpEx KPI as costs associated with maintenance and repair, research and development, and short-term lease. Thule Group used the definition of OpEx which is stated in 1.1.3.1 of Annex I in the Commission Delegation Regulation<sup>1</sup> (EU) 2021/2178 for the calculations of the OpEx KPI. The numerator equals to the part of the operating expenditure included in the denominator of activities 7.2 to 7.6 and 2.3. The denominator represents all Operating expenses, including the non-eligible activities.

In 2024, Thule’s total Operating Expenses, according to the Taxonomy definition, 131.9 MSEK.

The company considered only the maintenance and repair activities associated with Taxonomy activities 2.3 and 7.2 to 7.6.

7.2 to 7.6 Construction Sector, reporting 4.49 MSEK eligible, 4.47 MSEK aligned.

2.3 Collection and Transport of non-hazardous and hazardous waste Management, reporting 5.75 MSEK of the reported eligible/aligned activities.

## TURNOVER

For the first time, Thule is able to report on turnover, as the EU Taxonomy Compass has included sale of spare parts beyond the warranty period, as an activity that qualifies for the taxonomy eligibility.

In 2024, Thule had a revenue of 79 MSEK from sale of spare parts, which was 100 percent

eligible, and aligned. We make efforts to extend the average product lifespan by providing spare parts, reducing waste generation and the need for new product manufacturing. In 2024, sale of spare parts accounted for 0.8 percent of our revenue; these parts are primarily purchased by customers/consumers to meet repair demands, ensuring that the products remain functional for years, while supporting sustainable production and consumption.

## MINIMUM SAFEGUARDS

The Taxonomy Regulation defines the minimum safeguards as procedures implemented by a company to ensure alignment with the OECD Guidelines for Multinational Enterprises and the UN Guiding Principles on Business and Human Rights, including the eight fundamental conventions identified in the Declaration of the International Labour Organisation on Fundamental Principles and Rights at Work and the International Bill of Human Rights. Human rights are embedded in the Code of Conduct (CoC), which provides clear guidance to our internal and external stakeholders; it also describes the principles and regulations we follow in our operations, where sustainability and human rights are key values integrated into those principles. We firmly adhere to the UN Declaration of Human Rights principles, and we are a proud signatory of the UN Global Compact. We are also committed to the human rights instruments, including the ILO’s

eight fundamental conventions and the OECD Guidelines for Multinational Companies. Accordingly, we assess our Taxonomy-eligible activities as compliant with the minimum safeguards.

<sup>1</sup>) L\_2021443EN.01000901.xml (europa.eu)



See also pages 130–133.

# Climate Change

## CLIMATE ACTION – AN INTEGRAL PART OF OUR VALUE CHAIN

We produce long-lasting, high-quality, and safe products so that people can enjoy the outdoors. Caring about the environment is in our DNA, and it is in our business interest to minimize negative impacts on people and the environment as much as possible.

## TRANSITION PLAN FOR CLIMATE MITIGATION

Thule has an ambitious transition plan for climate change mitigation. Since 2020, we have committed to the Science Based Targets Initiative (SBTi) to reduce greenhouse gas emissions in scope 1, 2, and 3. In 2023, SBTi approved and validated our commitment to Net-Zero by 2050.

## SUSTAINABILITY POLICY

Our climate action targets are informed by our Sustainability Policy, a comprehensive framework for addressing key environmental, social, and governance aspects in our value chain, including climate mitigation and adaptation.

In addition to climate change mitigation and adaptation, we also address material topics such as emissions and focus on responsible production and consumption, adherence to our Restricted List of Substances (RSL), and human rights due diligence in our value chain. Our commitment is to ensure that our products are safe for people and the environment.

---

## TRANSITION PLAN FOR CLIMATE MITIGATION, TARGETS

---

- |                |   |
|----------------|---|
| <b>Scope 1</b> | 46.2 percent reduction, in absolute numbers, of greenhouse gases from our production sites, by 2030, compared with the base year 2019.                                    |
| <b>Scope 2</b> | Continue the active sourcing of 100 percent renewable electricity at our own manufacturing sites and offices with more than 12 employees until 2030.                      |
| <b>Scope 3</b> | An absolute reduction of greenhouse gases by 28 percent by 2030, related to purchased materials, and upstream and downstream logistics, compared with the base year 2019. |
- 



## Metrics and targets

### Actions and resources

We are actively working to achieve our emission reduction targets. Our production site decarbonization plans align with our Group’s Strategic plans until 2030, and will help us achieve the SBTi scope 1 target by 2030. In 2024, one of the key actions towards, emission reduction and climate change mitigation involved installing heat pumps in Pila, Poland, as part of our decarbonization strategy. We also aim to transition to a 100 percent electric or fossil-free vehicle fleet by 2025.

### Renewable Electricity

We have committed to actively sourcing 100 percent renewable electricity for all our sites and offices, with more than 12 employees. In 2024, we had 100 percent of renewable electricity. Thule has made acquisitions in 2024 and will include the newly acquired sites as part of the 100 percent renewable electricity coverage in 2025.

### Supply chain

Regarding decarbonization in the supply chain, we are working with our suppliers to procure lower-emission materials, and increase the share of recycled materials where technically feasible without compromising the safety and quality of our products. Despite increasing DTC logistics, we are also optimizing logistics to reduce emissions.

### Products

We also set targets for reducing product emissions. New products that meet certain financial thresholds must reduce emissions by at least 30 percent compared to a benchmark product, thereby integrating emission reduction strategies into R&D. In 2024, we significantly reduced emissions in our new Thule EasyFold 3 compared to the previous product. Thule EasyFold 3 reduced emissions by 50 percent compared to the previous generation, due to the reduced weight of aluminum, using lower-emission aluminum and recycled plastic. We also designed for durability and reparability to extend the product’s life.

**100** percent electric or fossil-free vehicle fleet by 2025.

**100** percent of renewable electricity.

### Carbon Disclosure Project (CDP)

In 2024, Thule Group requested 178 suppliers (representing 90 percent of purchased spend in 2024) to disclose their emissions data and environmental impact via the Carbon Disclosure Project (CDP). These efforts are geared toward reducing emissions and enhancing social responsibility throughout our value chain.

### GHG emissions

We follow the GHG Protocol Corporate Accounting and Reporting Standard to disclose our scope 1, 2, and emissions. We do not account for Category 10, 11, 13, 14, and 15 as they are not within our operational control or not applicable. In 2023, Thule Group conducted a baseline recalculation of our scope 1, 2, and 3 emissions, as SBTi recommends a recalculation every 5 years.

While we did not undergo any structural changes in 2023, the primary changes in the emissions calculation were in methodology due to increased knowledge about purchased materials and emission factors. The updated calculations showed a difference of 3.3 percent in scope 3 emissions in 2019, which is under the SBTi threshold of 5 percent, so we do not need to reformulate existing short-term SBTi targets.

Thule has made two acquisitions in 2024. However, emissions from those acquisitions are excluded in the 2024 inventory. In 2025, we plan to map the total emissions from those two entities, when we publish the 2025 Annual Report.

### E1-5 ENERGY CONSUMPTION AND MIX (TOP LEVEL)

Energy Consumption from fossil sources (MWh)	2024	2023	2022
Coal and coal products	0.00	0.00	0.00
Crude oil and petroleum products	12,025	10,244	11,253
Natural gas	3,896	4,232	4,435
Other fossil sources	0	0	0
Purchased or acquired electricity, heat, steam, cooling from fossil sources	239	1,175	83
<b>Total energy consumption from fossil sources</b>	<b>16,160</b>	<b>15,651</b>	<b>15,772</b>
<b>Total energy consumption from nuclear sources</b>	<b>0</b>	<b>0</b>	<b>0</b>
<b>Energy consumption from renewable sources</b>	18,273	17,383	21,040
Fuel consumption for renewable sources including biomass (also comprising industrial and municipal waste of biologic origin), biofuels, biogas, hydrogen from renewable sources	1,520	1,232	1,344
Purchased or acquired electricity, heating, steam and cooling from renewable sources	15,765	13,647*	18,976*
Self-generation of nonfuel renewable energy	988	2,503	720
<b>Total energy consumption from renewable sources</b>	<b>18,273</b>	<b>17,383</b>	<b>21,040</b>
Share of total energy consumption from renewable sources, %	53	53	57
<b>Total energy consumption</b>	<b>34,433</b>	<b>33,034</b>	<b>36,812</b>
<b>Total energy consumption from activities in high climate impact sectors</b>	<b>34,433</b>	<b>33,034</b>	<b>36,812</b>
<b>Energy production</b>			
Total non-renewable energy produced	10	12	26
Total renewable energy produced	988	2,503	720
Total energy produced	998	2,515	747
Energy intensity (total energy consumption per net revenue), MWh/SEKm	3.61	3.62	3.63

\*The data for 2022 and 2023 energy consumption from fossil sources, have been revised to correct the emission of fuel from company cars. As a result, the total non-renewable fuel consumption in 2022, of 10,500 MWh and 10,900 MWh in 2023 have been amended (refer to Thule Group 2023 Annual Report). Additionally, the reported values for purchased or acquired electricity, heating, steam, and cooling from renewable sources have been corrected due to calculation errors in purchased electricity, resulting in an adjustment of electricity consumption from 19,400 MWh in 2022 to 18 976, and total renewable purchased electricity of 15, 900 MWh in 2023 has been amended to 13,647 MWh. The total purchased renewable electricity is at 100%, so it is consistent with our Scope 2 target. However, the share of total energy consumption from renewable sources, according to the ESRS disclosure requirements, is calculated together with the energy consumption also used for energy production, as well as other fuels used for heating, vehicles etc. Therefore, that share of renewable energy is not exclusive to electricity consumption.

## Metrics and targets

### GREENHOUSE GAS EMISSIONS PER NET REVENUE

	2024	2023	2022	2021*	2020*	2019*
Total GHG emissions (location-based) (tCO <sub>2</sub> eq)	211,105	178,296	268,833	N/A	N/A	N/A
Total GHG emissions (market-based) (tCO <sub>2</sub> eq)	205,914	173,319	262,141	325,759	228,231	266,397
Emissions (location-based) per net revenue (tCO <sub>2</sub> eq/SEKm)	22.13	19.52	26.52	N/A	N/A	N/A
Emissions (market-based) per net revenue (tCO <sub>2</sub> eq/SEKm)	21.58	18.98	25.90	31.37	29.16	37.85

\*Third party verified location-based emissions for 2019-2021 are not applicable, as the addition of purchased goods to scope 3 in 2022, and subsequent baseline recalculations for total emissions are only applicable from 2022 onwards.

### GREENHOUSE GAS EMISSIONS LOGISTICS – EMISSIONS, TONS OF CO<sub>2</sub> EQ NET REVENUE

Transportation Type	2024	2023	2022	2021	2020	2019
Rail	86	76	275	654	424	155
Air	2,038	933	2,516	6,556	6,705	3,163
Sea	3,137	2,794	5,945	5,730	7,745	7,147
Road	9,668	11,082	15,233	15,838	13,298	9,941
<b>Total</b>	<b>14,930</b>	<b>14,884</b>	<b>23,969</b>	<b>28,778</b>	<b>28,172</b>	<b>20,407</b>

### E1-6 GROSS SCOPES 1, 2, 3 AND TOTAL GHG EMISSIONS, TON CO<sub>2</sub>EQ

	Retrospective				Milestones and target years		
	Base year, 2019	Comparative, 2023	2024	% 2024/2023	2030	2050	Annual % target / Base year
<b>Scope 1- GHG emissions</b>							
Gross scope 1 GHG emissions (tCO <sub>2</sub> e)	3,185	3,173	3845	21	1,714	319	5
Percentage of scope 1 GHG emissions from regulated emission trading schemes (%)	0	0	0	0			
<b>Scope 2- GHG emissions</b>							
Gross location-based scope 2 GHG emissions (tCO <sub>2</sub> eq)	N/A	5,192	5,327	3			
Gross market-based scope 2 GHG emissions (tCO <sub>2</sub> eq)	272	215	136	-37			
<b>Significant scope 3 GHG emissions</b>							
Total Gross indirect (scope 3) GHG emissions (tCO <sub>2</sub> eq)	262,940	169,931	201,932	19	189,317	26,294	3
1 Purchased goods and services	238,859	151,262	163,643	8			
2 Capital goods	N/A	0.00	16,740				
3 Fuel and energy-related activities (not included in scope 1 or scope 2)	85	1,916	1,967	3			
4 Upstream transportation and distribution	11,224	4,660	5,287	13			
5 Waste generated in operations	N/A	N/A	219				
6 Business Travels	3,589	1,869	4,433	137			
9 Downstream transportation	9,183	10,224	9,643	-6			
<b>Total GHG emissions</b>							
<b>Total GHG emissions (location-based) (tCO<sub>2</sub>eq)</b>	<b>N/A</b>	<b>178,296</b>	<b>211,105</b>	<b>18</b>			
<b>Total GHG emissions (market-based) (tCO<sub>2</sub>eq)</b>	<b>266,398</b>	<b>173,319</b>	<b>205,914</b>	<b>19</b>			

## Metrics and targets

### CALCULATION FACTORS E1-6

Unit	Data Point	Factor	Comment	Reference	Publication name
Ton CO <sub>2</sub> e	Scope 1 emissions	Carbon emissions from fossil fuels and biogas	Oil, natural gas, biogas, LPG for heating and operations	UK Department for Environment, Food & Rural Affairs (DEFRA), 2024	UK government conversion factors for company reporting of greenhouse gas emissions, 2024
Ton CO <sub>2</sub> e	Scope 1 emissions	Company vehicles	Diesel, petrol, ethanol	DEFRA, 2024	UK government conversion factors for company reporting of greenhouse gas emissions, 2024
Ton CO <sub>2</sub> e	Scope 2 emissions	Purchased electricity (Location-based)	(Average grid electricity emissions for each region)	Association of Issuing Bodies (AIB), 2023; Renewable Energy Certificates; International Energy Agency (IEA), 2024; Green-e, 2023	European Residual Mixes, 2023; International Energy Agency, 2024; Green-e Renewable Energy Mix Standard (2023)
Ton CO <sub>2</sub> e	Scope 2 emissions	Purchased electricity (Market-based)	Renewable energy certificates (RECs) and supplier contracts)	Green-e, 2023; IEA, 2024; AIB, 2023	Green-e Renewable Energy Mix Standard (2023; International Energy Agency, 2024; European Residual Mixes, 2023
Ton CO <sub>2</sub> e	Scope 3 emissions	Logistics emissions	DEFRA factors for modes of transport (air, sea, rail, road FTL, road LTL)	DEFRA, 2024	UK government conversion factors for company reporting of greenhouse gas emissions, 2024
Ton CO <sub>2</sub> e	Scope 3 emissions	Purchased goods and services	Product category emission factors	Supplier EPDs; EcolInvent v3.91, 2022	EcolInvent v3.91 (2022)
Ton CO <sub>2</sub> e	Scope 3 emissions	Business travel, covering flights, car rentals, and hotel stays.	Emissions based on travel mode (air, land, sea), distance, or spend	DEFRA, 2024; Hotel Footprinting Tool, 2023; Exiobase 3.9, 2019	UK government conversion factors for company reporting of greenhouse gas emissions, 2024; Hotel Footprinting Tool, 2023; Exiobase 3.9, 2019
Ton CO <sub>2</sub> e	Scope 3 emissions	Company vehicles, fuel and electric cars charged off site	Diesel, petrol, ethanol, FAME100, B100 (RME) and electricity (market-based and location-based factors)	DEFRA, 2024; Drivkraft Sverige Beräkningsfaktorer, 2024; Energimyndigheten Drivmedel, 2024; Circle K, 2023; IEA, 2024; AIB, 2023	UK government conversion factors for company reporting of greenhouse gas emissions, 2024; International Energy Agency, 2024; European Residual Mixes, 2023
Ton CO <sub>2</sub> e	Scope 3 emissions	Waste	Hazardous waste (recycled and non-recycled), non-hazardous waste (landfilled, recycled, incineration)	DEFRA, 2024	UK government conversion factors for company reporting of greenhouse gas emissions, 2024
Ton CO <sub>2</sub> e	Scope 3 emissions	Purchased goods (aluminum, plastic, packaging)	Emission factors depend on product categories	Supplier EPDs; EcolInvent v 3.91, 2022	EcolInvent v3.91 (2022)
Ton CO <sub>2</sub> e	Scope 3 emissions	Purchased goods (textiles)	Emissions vary by material type (e.g., polyester, nylon)	Worldly Higg, 2024	Higg Materials Sustainability Index, 2024
Ton CO <sub>2</sub> e	Scope 3 emissions	Capital goods	Emission factors based on type of capital goods	Supplier EPDs; EcolInvent v3.91, 2022	EcolInvent v3.91 (2022)
Ton CO <sub>2</sub> e	Scope 3 emissions	Upstream emissions from purchased electricity	Generation, transmission, and distribution emissions	EcolInvent v3.91, 2022	EcolInvent v3.91 (2022)

# Climate Scenario analysis

**We use the recommendations of the Task Force on Climate Related Financial Disclosures (TCFD) to identify climate risks, which we categorize according to physical risks, and transitional risks.**

**Our analysis combines the three following scenarios, that draw on the Shared Socioeconomic Pathways (SSP's) from the Intergovernmental Panel on Climate Change's (IPCC Sixth Assessment Report on Climate Change in 2021.**

**1** Very low and low GHG emissions and CO<sub>2</sub> emissions declining to net-zero around or after 2050, followed by varying levels of net negative CO<sub>2</sub> emissions (SSP1-1.9 and SSP1-2.6), which aligns with the Paris Agreement.

**2** Intermediate GHG emissions (SSP2-4.5) and CO<sub>2</sub> emissions remaining around current levels until the middle of the century, are referred to as Intermediate Climate Action.

**3** High and very high GHG emissions (SSP3-7.0 and SSP5-8.5), and CO<sub>2</sub> emissions that roughly double from current levels by 2100 and 2050, are referred to as Poor Climate Action.

Physical risks include acute (coastal flood hazard, drought hazard, extra-tropical cyclone hazard, flood hazard, landslide hazard, severe storm hazard, tropical storm and cyclone hazard and wildfire hazard) and chronic risks (climate change exposure, cooling degree days, heating degrees days, heat stress, sea level rise, water stress). Transitional risks include policy, market, technological and reputational risks from climate change impacts.

The climate scenario analysis helps us to ensure that our business strategies are resilient to climate change impacts in a range of possible future scenarios.

We have conducted a qualitative analysis to understand how climate impacts create risks and opportunities for Thule Group in the short term (2–5 years) medium term (5–10 years) and long term (10–15) years. The time frame is aligned with our key strategic plans, and external climate commitments.

**PARIS AGREEMENT SCENARIO; 1.5 DEGREES** (SSP1-1.9 and SSP1-2.6) is aligned with the goals of the Paris Agreement, and requires significant reductions of global emissions, including net-zero targets for carbon dioxide (CO<sub>2</sub>) emissions before the end of the century.



Thule Subsola, Thule Öutset

In this scenario, an active awareness of the urgency of decarbonization, drives collaborative actions across governments and companies to reduce emissions to Net-Zero by 2050. This will put the world on track to limit global warming to 1.5 degrees Celsius above preindustrial levels. However, while emissions growth is decoupled from economic growth, the effects of “locked-in” climate change impacts continue to impose costs. The sustained success of businesses depends on how effective their transition is to a low carbon economy.

Thule’s global targets are aligned with the SBTi 1.5 degrees target for 2030, and we are also committed to Net-Zero by 2050. The main risks and opportunities in this scenario for Thule are related to transitional impacts such as compliance with emerging policies and trends, transitioning to low emission technologies, decarbonization of sites, investing in climate resilient assets and properties. There are also market risks and opportunities associated with the price and availability of purchased goods and materials, and consequently in the products we offer. We will also have to adapt to the transitions in the external world in terms of transitions to energy, infrastructure, transport systems, and industrial systems.

**INTERMEDIATE ACTION; 2 DEGREES**

Global warming of 2°C would extremely likely be exceeded in the intermediate GHG emissions scenario. (SSP 2-4.5). While some economies use the prolongation of warmer periods, and shortening of colder periods as advantageous, it can be extreme heat and cold to others part of the world. Heat waves, rain and drought can be more intensified, and other physical impacts can get higher. The risk of impacts to the value chain is higher in this scenario.

Progress toward sustainability is slow, with disparate development and income growth. Business continues as usual, with slow progress in sustainability. There is a heavier cost to climate change mitigation and adaptation, as well as in disaster risk management.

**POOR CLIMATE ACTION SCENARIO; 3 DEGREES AND HIGHER**

In (SSP3-7.0 and SSP5-8.5) CO<sub>2</sub> and methane emissions continue to rise, fossil fuels are still in use even if there are significant declines in emission growth rates over the second half of the century. However, there are also improvements reduction on aerosols, as well as on energy efficient technologies.

Atmospheric CO<sub>2</sub> levels rise from current-day levels of 400 up to 936 ppm by the end of this century. CO<sub>2</sub>-equivalent levels (including emissions of other non-CO<sub>2</sub> greenhouse gases, aerosols, and other substances that affect climate) reach more than 1,200 ppm by 2100, and crossing the 2°C global warming level in the midterm and long term period, is very likely to occur under the very high GHG emissions scenario, and likely to occur under the high GHG emissions scenario (SSP3-7.0)

In a poor mitigation scenario, the world continues to prioritize short-term economic growth, driven by the continued use of fossil fuels and energy intensive activities and lifestyles.

Most economic and social efforts are in protecting people and businesses from climate change impacts, and climate adaptation measures become a heavy burden on organizations and the economy.

Under this scenario, the main risks for Thule are from physical climate impacts, which entails risks to productivity and physical assets, risks to supply chain, and physical environment which can prevent people from enjoying the natural environment, as well as risks from increased technological or energy efficient costs.

**Risks and risk management**

The table on the next page summarizes what Thule currently believes to be the most significant climate-related risks and opportunities relevant to our businesses with three scenarios – an imagined future that meets the goals of the Paris Agreement, one that makes intermediate efforts to meet the climate targets, and an alternate future with poor climate action.

These risks and opportunities were identified and mapped against our value chain, ranging from R&D, testing, supply chain, transport, manufacturing, business partnerships, and downstream product use impacts. The impacts are not listed in order of significance, nor are they exhaustive.

While they should not be seen as predictions, there is a value in bringing these scenarios to our collective imagination, to create an understanding of the magnitude of impacts, and to understand the urgency of responding to decarbonization.

When assessing risks and opportunities for transitional risks, we consider only the Paris Agreement scenario, and we assume a strict regulatory landscape in Europe, which is where 6 of our production facilities are, including our headquarters.

**CLIMATE-RELATED RISKS**

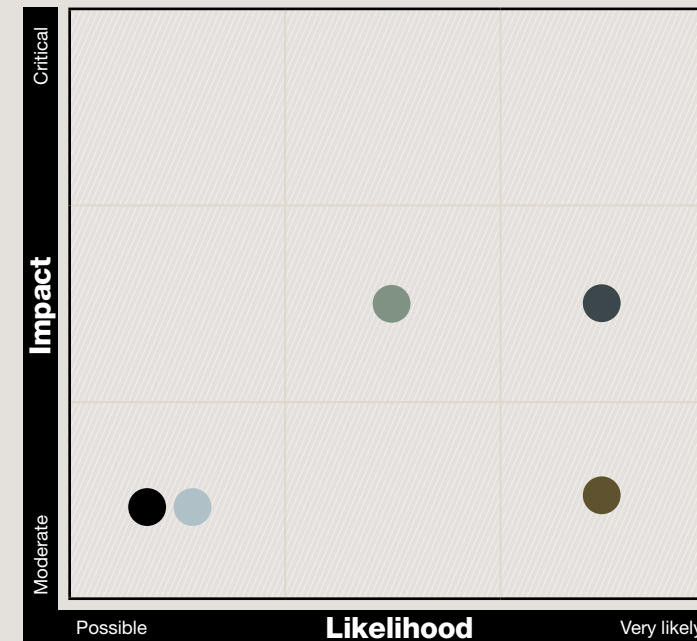

**PHYSICAL RISKS**

- Acute and chronic risks such as extreme weather events, flooding, droughts, wildfire hazards, climate change exposure, heat stress, sea level rise, water stress in value chain.

**TRANSITIONAL RISKS**

- Reduce demand for underlying products due to regulations or market factors, which affect demand for Thule products
- Supply chain limitations on sustainable materials
- Regulatory Landscape
- Decarbonization of sites, production processes and equipment

## Risks and risk management

Likelihood		Impact	
Very likely			Critical
Medium			Medium
Possible			Moderate

RISK	DESCRIPTION OF RISK	LIKELIHOOD IMPACT	TIME HORIZON	RISK CATEGORY	POTENTIAL IMPACT	OPPORTUNITIES & MITIGATING ACTIONS
<b>ACUTE AND CHRONIC WEATHER EVENTS</b>	<p><b>Own operations</b> Thule has facilities and offices in 13 countries in the world, comprising of 9 production facilities, assembly, warehouses, offices and stores within our operational control. Overall, the exposure risk for owned and leased manufacturing sites are low in an intermediate, and Paris Agreement scenario, as they are not located in high climate risk areas. Nevertheless, in a poor climate action scenario, different geographical areas are very likely exposed to different physical risks from climate change.</p> <p><b>Supply Chain</b> We have over 750 suppliers around the world. Chronic and acute weather events can lead to property loss or damage and can be devastating both for nature and people.</p> <p><b>Market</b> We sell our products in 138 markets, and if people are struggling with a climate catastrophe, that also means it puts the business at risk, since we are a company providing outdoor products for people to enjoy nature.</p>		Medium and long term	Physical risk	<p><b>Expenses from property damage and productivity loss from business disruption</b> Climate-related events could affect Thule's production sites, offices employees, suppliers, communities and customers – leading to direct and indirect costs, including losses in productivity or working days, increased costs for improving climate resilience, and higher insurance premiums, among others.</p> <p><b>Impacts to human health</b> Exposure to extreme weather events could also increase health risks to people including heat-induced illnesses, respiratory issues, physical injuries, and infectious diseases. Both the severe weather impacts and the health impacts could reduce employee productivity, thereby affecting revenue.</p>	<p>Out of 9 production sites, 8 sites are directly owned by the company. We have insurance coverage for our sites, to accommodate closure depending on different reasons.</p> <p>There are opportunities to make our sites more climate resilient. For an example, Thule can have rainwater harvesting to respond to water scarcity and droughts from climate change impacts, or to make use of increased rainfall in other sites. We also have an opportunity to use climate adaptation strategies when renovating or construction new buildings.</p>
<b>SUPPLY CHAIN LIMITATIONS ON SUSTAINABLE MATERIALS</b>	<p>Our focus is delivering premium products of the highest quality, and we are exploring options to help achieve our Science Based Targets, and Net-Zero commitment, through product design and development as well. However, there is a transitional risk in procuring sustainably processed materials, mainly steel, aluminum, and plastics, which meet our stringent quality and safety requirements, due to global availability challenges and price premiums.</p>		Short to medium	Market (transitional)	<p>There is a price premium associated with switching to sustainable materials, which also involves costs for changing a product without required machinery, and also to replace a product with more sustainable materials.</p>	<p>We have committed to achieving Net-Zero targets by 2050, whereby reducing GHG emissions and sustainable material choice will be incorporated into product design criteria. There is an increasing opportunity to attract more customers and consumers based on sustainable products. Our products are manufactured with a superior quality and can be used for a long time.</p> <p>We strive for our products to have as limited an impact on the climate and environment as possible, during their lifecycle, without compromising on safety, quality, function or lifespan. Currently we have a cradle-to gate LCA on 36 of our products and we are aiming to increase the scope. Our greatest opportunity to influence the products' long-term sustainability is during the development phase.</p>
<b>REDUCED DEMAND FOR UNDERLYING PRODUCTS DUE TO REGULATIONS OR MARKET FACTORS, WHICH AFFECT DEMAND FOR THULE PRODUCTS</b>	<p>Changes to market trends and consumer behavior could decrease the demand for underlying Thule products, such as vehicles, which can consequently reduce demand for Thule's sports and cargo category such as roof boxes, roof racks, and other vehicle related products. On the other hand, increased demand for nature activities and enjoying the outdoors without long distance traveling, can increase the demand for Thule products.</p>		As above	As above	As above	As above

RISK	DESCRIPTION OF RISK	LIKELIHOOD IMPACT	TIME HORIZON	RISK CATEGORY	POTENTIAL IMPACT	OPPORTUNITIES & MITIGATING ACTIONS
<b>REGULATORY LANDSCAPE</b>	<p>Emerging and current regulations such as CSRD, CBAM, DPP, CSDDD, EUDR, and others, pose a transitional risk as we are increasing internal resources to adhere to the regulations.</p> <p>A lot of European countries are also shifting towards more and more bike friendly policies, which divest from car infrastructure, and while that could make it challenging for car ownership, it would facilitate demand for bike lifestyles, and consequently for Thule bike products.</p>		Short to medium	Policy (transitional)	<p>The costs are assumed as part of overall operations management.</p> <p>Positive attitudes towards bike ownership, and policy shifts in bike infrastructure in cities leads to positive impacts for Thule's bike category, and potential sales boosts.</p>	<p>Achieving Net-Zero targets means it allows us to make our production and operations more efficient, and more in line with environmental, social and health and safety best practices and standards.</p> <p>We are well prepared to implement the regulatory requirements by incorporating eco-design into our products, investing in sustainability in our operations, and streamlining our upstream and downstream due diligence procedures with the policy landscape.</p> <p>There is a significant opportunity in bike category as more people shift to bike commuting lifestyles.</p>
<b>DECARBONIZATION OF SITES, PRODUCTION PROCESSES AND EQUIPMENT</b>	<p>Decarbonization of our sites by transitioning to renewable energy sources is a transitional risk. Investing in energy efficient machinery and technology can be associated with payback periods of several years.</p> <p>Existing machinery and technology are also used for many years once it is purchased, which can result in lost opportunities to invest in new best available technology and machinery, as the technological landscape is evolving.</p> <p>Thule is aiming to transition all of our vehicle fleets to electric vehicles by 2025, which depend on batteries containing lithium-ion batteries, which can have potential climate and sustainability risks upstream for mining those minerals.</p>		Short, medium, and long term	Technological (transitional)	<p><b>Decreased access to capital</b> A potential delay of future investments in Best Available Technologies (BAT) could be an outcome of Thule's investments in modern and energy-efficient technology.</p> <p><b>Expenses from increased price of renewable energy</b> As water availability becomes scarce due to climate change, it will increase operating costs for Thule. In addition, the operating expenses to secure renewable electricity, and switch to renewable heating for sites is also costly.</p>	<p>Thule owns 8 out of 9 production sites so we can invest in climate resilient buildings, invest in renewable energy, or lower emission technologies that are more efficient. This can contribute to lowered costs and higher operational efficiencies in the long term.</p>

POLLUTION

# Products that are safe for people and the environment

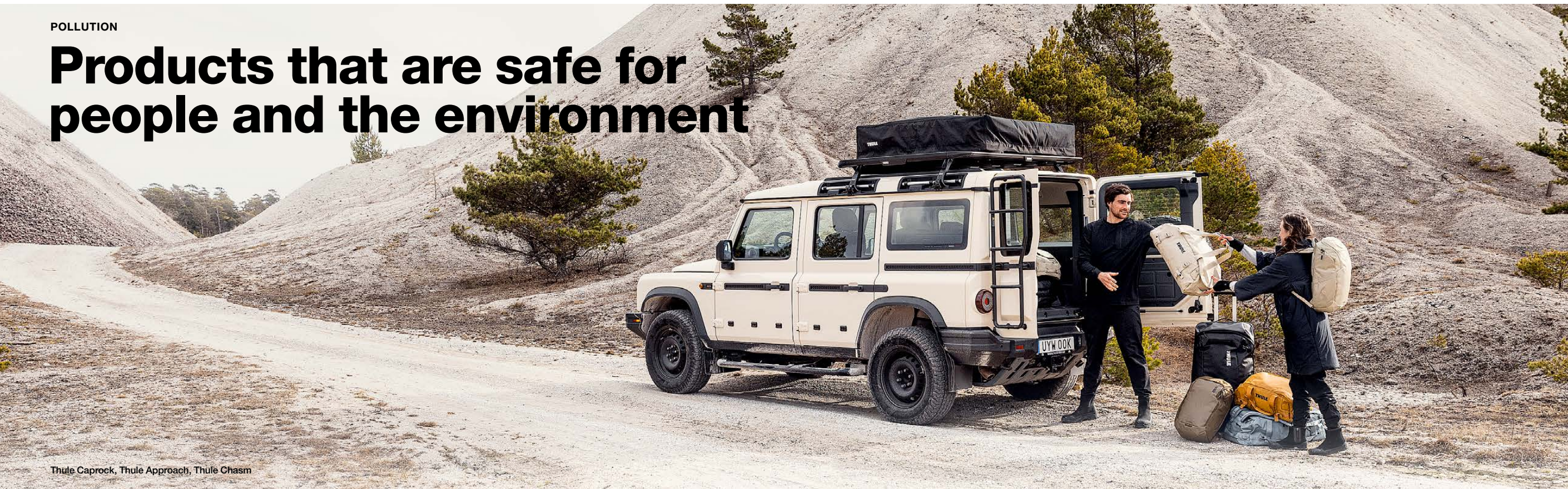

Thule Caprock, Thule Approach, Thule Chasm

**We are in the business of manufacturing high quality outdoor products, that are safe for people and the environment. Responsible chemical management is a vital part of our product design and development, and core operations, and it is aligned with our commitment to SDG 12: Responsible Consumption and Production.**

## POLICIES

Thule's Sustainability Policy, Chemicals Policy, and Supplier Code of Conduct aim to minimize environmental impacts and manage pollution and hazardous substances across our value chain. These policies are approved by the Board. Our Sustainability Policy focuses on reducing emissions and pollution to air, water, and soil, reducing impact from noise pollution, and protecting people and the environment from harmful and hazardous chemicals. The Chemicals Policy and the Supplier Code of Conduct require suppliers to adhere to Thule's Restricted Substances List (RSL), with proactive efforts to phase out harmful substances

in our production, and in upstream operations. Together, these policies reinforce Thule's commitment to product safety and responsible chemical management, by minimizing negative impacts to air, water and soil in our operations, and by prioritizing chemical safety in our products.

## OUR IMPACTS AND ACTIONS TAKEN IN 2024

We comprehensively track, measure and document emissions (air, water, soil and noise emissions from facilities and transport) and waste streams, and our production sites are ISO 14001 certified.

In 2024, we conducted a site pollution screening for emissions to air to establish a reporting baseline

with the CSRD and Regulation (EC) No 166/2006. Our baseline assessment confirmed minimal pollutant emissions, primarily from truck emissions, biogas heating, prototype productions in R&D (notably zinc), and PVC-fabric welding for awnings. However, based on our site pollution screening in 2024, as well as the supplier data we assessed from a selection of our tier 1 suppliers, the emissions are below the threshold, according to the Regulation (EC) No 166/ 2006, thereby making the impacts below the threshold.

We will continue to review the impacts and risks in 2025, so that we can consider new information when determining materiality in 2025.

For our 2024 reporting, the material topics are Substances of Very High Concern (SVHCs), and Substances of Concern (SoCs).

**SAFE PRODUCTS**

Safe and responsible use of chemicals is a critical part of product safety. Thule uses various strategies to ensure that our products meet the requirements in the Thule Restricted Substances List (RSL), and all relevant regulatory requirements. Our products are subject to various regulations including but not limited to, (EC) No 1907/2006 REACH, including both Annex XVII restrictions, and article 59 (10) candidate list, the (EU) No 2019/1021 POPs regulation, U.S Federal regulations such as the Toxic Substances Control Act (TSCA 40 CFR Part 751), and state regulations such as the Safe Drinking Water and Toxic Enforcement Act of 1986 (California Prop65). Thule conducts regular testing of products both during product development stages, as well as recurring during products’ production lifetime. We are also members of various organizations and networks that promote the safe use of chemicals, including the Chemicals Group at RISE (Research Institutes of Sweden). The combination of such strategies ensures that our products placed on the market are compliant with relevant regulations and meet the applicable stringent safety standards.



Thule Maple, Thule Shine

Thule reports Substances of Very High Concern (SVHC’s) as part of the reporting obligations under the Waste Framework Directive (WFD). Components containing SVHC’s on the REACH Candidate List, in a concentration above mg/kg (or weight by weight (w/w) are reported on the Substances of Concern on the articles as such or for complex objects in the Products (SCIP) database. We receive information from suppliers on the presence of SVHC’s in articles, such as pertaining to Article 33, regarding the obligation to communicate information on substances in articles. This information is typically verified and complemented by testing as mentioned above. The reporting is done to ensure that information on the articles containing the SVHC’s are available throughout the lifecycle of the products.

**Actions taken**

**PHASING OUT PFAS**

PFAS, or per- and polyfluoroalkyl substances, refer to over 10,000 synthetic compounds that resist breakdown and can harm health and the environment. We design new products to exclude PFAS and update existing ones to minimize their use and have committed to launch no new textile products with PFAS since January 2024, and committing to stop manufacture of products with PFAS from 2025 onwards.

**THIRD PARTY TESTS**

In 2024 we also strengthened our work with third parties to conduct stringent testing on our products. One highlight of 2024 is that our Child Car Seats, Thule Maple, Alfi and Elm, got high scores in the prestigious and stringent ADAC test for quality and safety. Several of our textile products are also bluesign® approved.

**PLANNED ACTIONS**

In 2025, we plan to develop a formalized risk matrix for chemical risk management, which would screen and assess products based on certain criteria. We also plan to engage with our suppliers to increase confirmation of adherence to our RSL.

For Substances of Concern (SoC), we will create a procedure to map SoCs to our RSL, identify gaps, update them as needed, and ensure supplier adherence.



Thule Allax

## RESOURCE USE AND CIRCULAR ECONOMY

# Eco-design principles for more than a decade

**Our greatest opportunity to influence the products' long-term sustainability is during the development phase and Thule has been working with eco-design principles since 2012. Long-lasting, innovative and high-quality products are at the heart of our business.**

By analyzing the materials, production processes, user phase and recycling potential, we strive for our products to have as limited an impact on the environment as possible, without compromising on safety, quality, and function. Our focus in circular economy is on resource inflows, the materials we buy and use in production, how we design and manufacture products, and resource outflows, the material outputs and minimizing the impacts from those materials, and our products.

Our products are mainly manufactured from aluminum, steel, plastic, textiles. Packaging contain mainly corrugated material, but also plastics.

Thule's Sustainability Policy, our Supplier Code of Conduct, and LCA Procedure during Product Development establish our commitment to advancing a circular economy by integrating ecodesign, efficient material use, and enhanced

waste management. Additionally, suppliers are required to monitor and track their emissions, report on their chemicals in line with our Restricted Substances List (RSL), and share information related to their materials and processes.

Our policies apply across Thule Group's operations, and include the upstream and downstream value chain, emphasizing sustainable practices from sourcing to end-of-life. We prioritize lower emissions and recycled materials over virgin materials, where technically feasible, while maintaining high standards for product safety and durability.

In 2024, Thule took significant steps to integrate ecodesign principles in R&D, using our in-house LCA's to guide our product development process. We also invested in tools such as Worldly and Ecochain Mobius, to expand the scope of our life cycle assessment on our products, and to refine the quality of our analysis.

## Life cycle analysis – a comparison

When developing new products, current or similar versions are assessed to see how the product materials contribute with CO<sub>2</sub>eq emissions. By analyzing the input materials, we identify high emission contributors and can take active decisions regarding material type and geographical origin of the resources. We also investigate how recycled options or materials produced with renewable electricity could reduce the climate impact of the new product.

**UPGRADED VERSION CUT EMISSIONS IN HALF**  
As example, this methodology was applied during the development of Thule EasyFold Gen 3 where Thule EasyFold XT served as benchmark. By reducing the usage of aluminum, using aluminum produced with hydro power and recycled plastics where possible, a 50 percent emission reduction from the product materials could be achieved.

**MATERIAL EMISSIONS EASYFOLD XT 3B VS GEN 3, KgCO<sub>2</sub>eq**

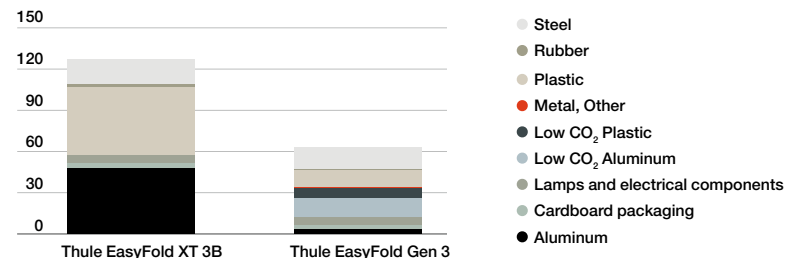

\* Note that these calculations are not third party verified and should not be seen as either LCA's or Environmental Product Declarations. Instead, they serve as fundamental input in the development of new products to ensure that sustainable decisions are taken in alignment with our target to reduce scope 3 emissions with 28 percent by 2030.

### Thule EasyFold XT 3B

**Raw material weight and emissions**

Plastic weight (kg)	6.2
Plastic emissions (kgCO <sub>2</sub> eq)	49
Aluminum weight (kg)	6.5
Aluminum emissions (kgCO <sub>2</sub> eq)	49
<b>Total emissions (kgCO<sub>2</sub>eq)</b>	<b>127</b>



### Thule EasyFold Gen 3

**Raw material weight and emissions**

Plastic weight (kg)	7.7
Plastic emissions (kgCO <sub>2</sub> eq)	17
Aluminum weight (kg)	4
Aluminum emissions (kgCO <sub>2</sub> eq)	17.5
<b>Total emissions (kgCO<sub>2</sub>eq)</b>	<b>63</b>

## Metrics and targets

### Targets

Our current targets related to circular economy and product sustainability include:

- All new development projects which are expected to reach above a certain financial threshold in the second year of sale, shall reduce their CO<sub>2</sub>eq emissions by a minimum of 30 percent compared to a defined benchmark product.
- All new development projects which are expected to reach above a certain financial threshold in the second year of sale, must evaluate their ecodesign performance in accordance with internal routines and processes.

Other targets include:

- Eliminate PFAS in all textiles by no later than 2025.
- Start to measure the level of recycled content per product family by 2026.
- Maintain a 98 percent recycling rate.
- Send no hazardous waste to landfill by 2030.

### Product environmental impact

We plan to extend the product environmental impact assessment to include impacts to water, chemical use, and impacts to biodiversity by 2025, enabling us to make more comprehensive, and data-informed decisions around product development. Thus, by embedding eco-design principles and information from LCA's, Thule expects to reduce material emissions and reliance on virgin materials, particularly in high-impact materials like aluminum, steel, and plastic.

Due to the diversity of our product portfolio, we have not yet set targets on recycled content on individual products, as each product, while going through the R&D product development phases, is subjected to a feasibility analysis for how much recycled content, or circular material use rate that can be applied.

From 2025 onwards, we aim to analyze the technical implications and applicability of these targets to relevant products, or product categories. However, we have made significant progress in using more recycled fabric in our Packs, Bags and Luggage product category. In 2023, we also committed to the Global Recycling Standard (GRS), whereby we committed to

source 100 percent GRS certified recycled nylon and polyester textiles by the end of 2024.

In 2025, Thule will also investigate how to launch digital product passports (DPP), so that we can better support our consumers in extending product life, accessing repair services, and recycling information. The DPP's will foster circular practices by informing customers about extending product life, repair options, and recycling pathways, supporting Thule's Net-Zero targets.

Our Sports&Cargo products such as roof boxes, bike racks, and Juvenile and Pet (JVP) products such as baby strollers can be passed down to family and friends, considerably extending the product's user phase. Years of internal market analysis of our products also reveal that they have a high second-hand value.

While the user phase is a relatively small part of climate and environmental impact in relation to upstream and downstream impacts, we place considerable focus on this because we want to ensure that the consumers can use our products reliably, and sustainably over a long time. When developing cargo boxes for small cars, for example, we analyze how the vehicle's energy consumption is impacted by the box's placement, but also ensure that the rack is easy to mount and unmount, so that the user does not leave it in place when not in use, thereby leading to higher energy consumption than necessary. We also provide repair services, and spare parts for products, both within and out of the warranty period, which contributes significantly to the extension of the product's life.

We provide limited warranties, extended warranties and lifetime warranties depending on the product category and are communicated on our website.

If customers are required to order spare parts or replacement products, Thule provides spare parts and accessories for products, as part of our commitment to provide the right customer care and support, but also as a reflection of our commitment to extend the product's life cycle. In 2024, Thule provided a total of 42,092 spare parts under warranty claims (in 2023 it was 54,900 pieces), and a total of 9,189 spare parts sold under non-warranty claims.

In 2024, we also have received 421 incident claims (515 claims in 2023) whereby customers would receive a replacement product. Incident claims are related to claims arising from damages to health or property. Thule also sets internal targets to reduce the number of

incident claims, spare parts or replacement products that are required, as this is related to the quality of the products. Targets are set on historical trends, past year data and the forecast of a product with regards to sales or production.

Thule is also committed to extending the product's life cycle by providing product repairs as a service. In 2024, we had a total of 2,939 repairs at our Thule Service centers in Poland, Germany, Belgium, and UK. In 2023, we had a total of 2,632 repairs.

### Sustainable Procurement – Resource Inflows

Thule's primary materials include aluminum, steel, plastics, textiles, and packaging materials, which are included in our reporting boundary for purchased materials. We categorize these as core inputs, while building materials for facilities are classified separately as capital goods, whereby we report those emissions depending on whether there has been a construction or renovation project that occurred within our operational control, in the reporting period.

We have also initiated a supplier engagement strategy in 2024, whereby supply data on material data, emission factors, processes, and circular economy initiatives are gathered from key suppliers. We will continue to work with our suppliers to increase the purchase of lower emission materials, acquire more Environmental Product Declarations (EPD's) and supplier data on materials, use more recycled materials where technically feasible, and to encourage our suppliers to reduce the environmental footprint from the materials we purchase.

We use exact measurements for volume of materials provided by suppliers, but for some categories such as fasteners or textiles, we use an estimated volume based on material composition.

Emissions from purchased materials are based on emission factors from DEFRA 2024, EcolInvent 3.91, and supplier-specific data. In 2024, we also updated our emission factors exclusively for textiles, using Worldly Higg's database. We are working to acquire more supplier specific data.

<b>WARRANTIES</b>		
<b>Product Categories</b>	<b>Europe and Rest of the World (ERoW) Warranty Duration</b>	<b>U.S. Warranty Duration</b>
Sports & Cargo	5 Years	25 Years
RV Products	2 Years	2 Years
Packs, Bags, and Luggage	5 Years	25 Years*

\*Thule laptop sleeves, cases, and protective bumpers have a product warranty of 2 years in the U.S.

<b>JUVENILE AND PET PRODUCT CATEGORY</b>		
	<b>ERoW Warranty Duration</b>	<b>U.S. Warranty Duration</b>
Juvenile bike seats	5 Years	5 Years
Bike trailers, multisport trailers	5 Years	25 Years
Dog crates	5 Years	2 Years
Strollers	3 Years	25 Years on frame/3 years fabric and parts
Child car seats	3 Years	Not released in the North American market

<b>2024 MATERIAL RESOURCE INFLOWS – MATERIALS USED (METRIC TONS)</b>		
<b>Material</b>	<b>Weight (tons)</b>	<b>Emissions from all materials (tCO<sub>2</sub>e)</b>
Steel	10,619	27,050
Aluminum	10,455	61,328
Plastic	11,080	45,953
Textiles	2,888	21,243
Packaging	7,189	8,069
<b>Total</b>	<b>42,231</b>	<b>163,643</b>

## Metrics and targets

### RECYCLED INPUT MATERIALS USED

Year	Plastic		Paper Packaging		Textiles	
	Weight of recycled materials (metric tons)	% of recycled materials used	Weight of recycled materials (metric tons)	% of recycled materials used	Weight of recycled materials (metric tons)	% of recycled materials used
2024	5,943	54	2,617	38	258	9
2023	4,881	47	565	10	115	4
2022	1,173	8	1,793	29	69	2

## Products – Resource Outflows

Our products can be disassembled at the end of life according to instructions, and recycled for materials such as aluminum, plastic or steel. However, recycling materials made of combined materials, such as textiles or other material combinations can be challenging. Product details including the weight of the products are included in the individual product specifications and available to the consumer.

Thule Group is also reporting according to the Extended Producer Responsibility (EPR) regulations, in over 15 European countries, including Sweden, the UK, Germany, France, the Netherlands, Spain, Austria, Belgium, Italy and the Czech Republic. In 2024, we reported 3.3 million kg of products related to recyclable materials, including plastics, packaging, waste electrical components, and batteries. Thule Group is actively working towards maximizing the recyclability of the materials used in the products as an effort to contribute to the circular economy and reduce waste in our industry. The data is third party verified.

### Resource Outflows related to the production

We aim to minimize the use of materials in our production and ensure that scrap materials and waste are responsibly handled.

Around 87 percent of waste was recycled in 2024 (67 percent directly as recovery of key materials), and 20 percent of plastic regrind could be incorporated into our roof boxes. Another 8 percent of total waste undergoes waste-to energy operations. Less than 1 percent is sent to the landfill.

All production sites, and warehouses in our operational control report on waste, and offices with more than 12 employees. For some rented offices, that are not attached to production sites, the waste collection services and data are embedded into commercial agreements related to the lease of the building, so it is excluded out of our reporting boundary.

To calculate waste weight, Thule Group collects data on waste materials by different waste streams, based on the volume of waste generated, and reported every quarter according to how the waste was disposed. The waste volumes also documented by third party waste management partners for scrap materials such as metal, cardboard, and plastic waste.

### WASTE BY TYPE AND DISPOSAL METHOD

Metric tons	2024
<b>Total waste generated (metric tons)</b>	
Total hazardous waste	489
Total non-hazardous waste	6,428
<b>Total waste</b>	<b>6,917</b>
<b>Total recycled waste</b>	<b>6,854</b>
Total non-recycled waste	63
Percentage of non-recycled waste	0.91
<b>Hazardous waste (metric tons)</b>	
Waste for incineration	0.2
Waste for landfill	14
Total waste directed to disposal	14
Recycling	275
Waste to energy recovery	200
Total waste diverted from disposal	475
Total hazardous	489
<b>Non-hazardous waste (metric tons)</b>	
Waste for incineration	0.8
Waste for landfill	48
Total waste directed to disposal	49
Recycled plastic materials	1,522
Recycled metals	2,661
Recycled cardboard and wood	1,302
Composting	3
Other	540
Waste to energy recovery	351
Total waste diverted from disposal	6,379
Total non-hazardous waste	6,428

## Additional data points below materiality thresholds

### Water and marine resources

#### Water consumption and water management

Thule’s long-term objective is to reduce water consumption at all of its production facilities, increase the share of rainwater, and utilize closed loop systems as much as possible. Rain water is used at the facilities in Itupeva in Brazil, Huta in Poland, and Menen in Belgium. It accounted for 5 percent of the Group’s overall water consumption during the year.

## Biodiversity and ecosystems

Our manufacturing sites for our direct operations are neither built on, nor adjacent to protected areas or areas with high biodiversity value outside the protected area. Our operations are also guided by local, national, or regional environmental laws and ordinances, where we perform environmental impact assessments and minimize the risks of biodiversity loss by monitoring the impact on water, soil, and air. Thule is aware of the potential impacts on biodiversity that can arise upstream in our supply chain since our products contain aluminum, steel, plastic, and textiles, and we use packaging from paper and synthetic materials. Our Supplier Code of Conduct, Sustainability Policy, Biodiversity Statement, and Chemical Policy, provide a comprehensive framework for suppliers regarding their impact on the natural environment, including biodiversity and impact on people. Suppliers must also follow Thule Group’s Human Rights Policy, which takes environmental rights, such as soil and forest rights, as key values for Thule.

### WATER WITHDRAWAL AND WATER CONSUMPTION

Millions of liters	2024	2023	2022	2021	2020	2019
Rainwater	23.34	24	26.33	27.72	20.26	21.79
Municipal water	1.24	0.86	1.16	1.20	0.85	0.66
<b>Total</b>	<b>24.58</b>	<b>24.86</b>	<b>27.49</b>	<b>28.92</b>	<b>21.11</b>	<b>22.45</b>
Water discharge (third party water discharge)	24.56	24.00	27.45			
Recycled water	0.01	0.86	0.04			
Turnover	9,541	9,132	10,138	10,386	7,828	7,038
Water consumption in relation to turnover (Million liters/SEKm)	0.0026	0.0027	0.0027	0.0028	0.0027	0.0032

## Metrics and targets

### Value Chain Engagement of Suppliers

Information on selected material topics with reporting boundary of Thule tier-1 impact, risk and opportunities.

In 2024, our supplier engagement approach was motivated by the following aims:

- ▶ **1** Get insight into our suppliers’ sustainability management, governance and ambitions (maturity).
- ▶ **2** Identify Impacts, Risks and Opportunities (IRO) hotspots in Thule’s supplier base in tier 1.
- ▶ **3** Inform the suppliers about upcoming reporting requirements and building partnerships in reporting.

Supplier selection was based on the following criteria:

▶ **Material category**

The aim is to get insight into our suppliers’ sustainability work throughout all Thule purchased goods categories.

▶ **Significance of supplier for Thule Group**

In each category, at least one of the chosen suppliers has a significant spend value, and or Thule Group will sustain or increase the spend in the coming years.

▶ **Representing the category structure**

One of the selected suppliers have to complement a high spend supplier to represent the remaining supplier base that potentially differs from the highest spend supplier. This differentiation can be the company location, production processes, or company size.

We selected suppliers representing 21.8 percent of the purchasing spend volume of 2024. They cover all Thule material categories (Aluminum, Steel, Plastics, Fasteners, Electronics, Finished Goods), and range from non-listed SMEs to large international corporations, with varied production processes (from producing company to trading company).

During 2025, the ambition is to expand the IRO analysis to the whole supply chains of purchased goods, thereby increasing the depth of the analysis, and investigate impacts in more sustainability topics.

### Summary of policies, actions and targets identified in the value chain

**Climate Change and Energy**

Supplier engagement on Climate Change and Energy Use shows that the majority of suppliers have medium to high risks, impacts and opportunities.

Due to restricting the impact assessment to supplier’s own operations, the biggest impacts were identified for the companies which operate own energy-intensive production facilities.

Suppliers are actively working on reducing their carbon footprint through various initiatives. Most suppliers have a policy, or similar corporate document to manage impacts, risks and opportunities regarding energy use and climate change. Many are calculating their emissions according to established protocols and setting Science-Based Targets. Many suppliers identified scope 3 as an area of improvement, both for setting reduction targets and improving data quality and coverage.

Efforts include improving energy efficiency, using green electricity, and setting ambitious goals such as achieving carbon neutrality by 2030. However, some suppliers face challenges due to energy-intensive processes and limited access to renewable energy sources. Overall, there is a strong commitment to reducing emissions and improving data quality related emissions. Several of the interviewed suppliers mentioned their ISO certifications or ambitions to get certified (14001, 45001, 5001, 9001), which influences their commitment and efforts for different sustainability topics positively.

**Pollution to air and chemical use**

For pollution to air and chemical use, the impact, risks and opportunities are generally lower than for the other assessed sustainability topics. Some suppliers have low impact due to limited chemical use, while others are working on reducing and substituting chemicals to mitigate their impact.

While the impact of pollution to air and chemical use varies among suppliers, there is a general focus on compliance with local and international regulations. While

only few of the suppliers have measurable and time-bound goals, the focus is on continuous efforts to reduce pollutants to air, substitute hazardous substances, and minimize chemical use.

**Resource use and circularity**

All selected suppliers have medium or high impacts, risks and opportunities. Compared to the other sustainability topics, the opportunity for having positive impacts is higher, i.e advancing circularity is also a focus areas for suppliers. Both for resource flows and waste management, a lot of potential for improvement has been identified by the suppliers.

Some suppliers that we have assessed are leaders in circularity in their sector, while others are following the lead. This includes developing, producing and using recycled and biobased materials, improving the reparability of products, and collaborating with other actors in the supply chain on circularity. Other commonly mentioned topics were increasing resource efficiency, reducing scrap, selecting suppliers with lower emissions, and improving waste management.

# Social



## A shared passion for smart solutions and an active life

**For us at Thule, everything is about making it easy to live an active life. We pride ourselves in developing smart, innovative, and long-lasting products to which our employees contribute. We believe that background, origin, and experience complement and amplify our performance and achievement. Therefore, we want our employees to strive towards smarter and more creative working methods, and see opportunities in all parts of our business. All in an inclusive and safe environment that promotes health and well-being.**

### FOCUS AREAS

- Further reduce the number of accidents.
- Increase diversity and promote inclusion on all levels.
- Develop people and teams.
- Expand dialogue with our customers.

STRATEGY

# People strategy

We believe in people’s inherent power to push boundaries and find new solutions to today’s challenges. Still, we are simultaneously aware that to harness this power, we need to create an inclusive and multicultural environment where employees thrive and develop.

## Day-to-day operations

Healthy and safe working environment.

Training and Education.

Diversity and equal opportunities.

Brand building and talent attraction.

Employee satisfaction survey.

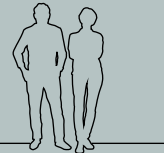

### Targets

- Zero tolerance toward harassment and discrimination.
- Increase diversity and promote inclusion at all levels.

### Policies

- Code of conduct
- Human Rights policy
- Anti-discrimination policy
- Privacy and IT security policy
- Whistle-blowing manual



Read more on pages 59, 64, 71

Interview with **Helena Dino**, Senior Vice President of HR

#### What has intrigued you the most since joining?

“The enormous pride in working at Thule, regardless of where you are in the organization and the high level of energy. Everyone is genuinely committed to the company’s success. We act with agility and make swift decisions to ensure continuous progress. It goes beyond the ordinary and I have a long experience of working at successful, large companies.”

#### Tell us more about the people strategy.

“Things are going well for Thule, and we have enormous drive and momentum, but to lift ourselves to the next level, we need to work even more to push down decisions and responsibilities in the organization and to support cross-functional collaboration. It will strengthen both employees and us as an organization.

Another key priority on our agenda is talent management. At the heart of our strategy is a deep commitment to leadership and talent development. We are confident that investing in the growth and potential of our people is essential to fueling sustainable, long-term success.”

#### What strengths within HR will you continue to build upon?

“Commitment and passion. They provide incredibly good conditions for creating a culture where everyone further develops their strengths. If we get all employees to grow, it will be reflected in our profitability.”

#### What are the biggest challenges going forward?

“Our business model where we need to find a large number of seasonal employees every year is one challenge, and another is to find the enormously elevated level of competence needed in our development center in Hillerstorp, Sweden. Although we are people who love an active life outdoors, some people still want to live in a big city.”

#### All employees seem to have their favorite Thule product, can you reveal yours?

“Our bags with well-thought-out functions, and above all the clothing inserts with a compression function that allows you to pack smart. It’s brilliant.”



OUR APPROACH AND POLICIES

# Caring is part of who we are



**Genuine concern for people and the environment is deeply rooted in our DNA, as is giving back to our society. We believe in people's inherent power to push boundaries and find new solutions to today's challenges. Still, we must create an inclusive and multicultural work environment where our employees can thrive and develop to harness this power.**

Thule has a strong corporate culture and underlying values essential for our continued success and long-term sustainable development. The Code of Conduct, Human Rights Policy, and Whistleblowing policy apply across our entire value chain, and the guidelines are the same worldwide. Our aim and efforts are centered on positively impacting our employees. The Code of Conduct assumes compliance with legislation and regulations. It is based on international standards such as the UN's Declaration of Human Rights, the UN Global Compact principles, ILO (International Labour Organization), and OECD guidelines.

The whistleblowing policy, drafted in line with the principles articulated in the Company's Code of Conduct, is vital to the Company's Corporate Compliance Program.

**ATTRACT, DEVELOP, AND RETAIN TALENT**

The collective strength of our employees' skills and experiences forms the basis of Thule Group's brand and success. The focus on sustainability, attractive products, and genuine core values attracts potential employees worldwide who say they can easily identify with us, our brands, and our products.

**SKILLS DEVELOPMENT GENERATES NEW IDEAS**

We are always on the move, pushing boundaries and introducing new creative products. Therefore, we offer various programs to improve and expand employees' skills. Our Online Academy is a comprehensive platform through which we offer policies, procedures, management development, leadership, professional qualifications, industry qualifications, and IT training. We also provide access to courses that third-party suppliers offer to meet specific requirements, such as communication, product development, leadership, calibration, geometric dimensioning and tolerance (GD&T), and software improvement training.

**EMPLOYEE SURVEYS**

Employees who are content and feel good, stimulated in their daily work and feel they can contribute and develop, are prerequisites for maintaining our strong position in the market. Every other year, we conduct a comprehensive employee survey of all our employees. In 2024, 84 percent of employees participated in a survey on workplace climate, environment, leadership, organization and core value. Overall satisfactions was 78 percent.

**SAFE AND SECURE WORKPLACES**

Thule prioritizes health and safety training programs to ensure all employees possess the necessary knowledge and skills to work safely. Our health and safety policy and ISO45001 certification form the guidelines toward our ambition to reach a work environment that not only promotes safety, but positive collaboration, job satisfaction, and a work-life balance. Our internal audits help us identify improvement areas, track the effectiveness of our actions, and encourage employees to participate in health and safety activities and training.

**A WORKPLACE CHARACTERIZED BY DIVERSITY AND EQUALITY**

We aim to offer all our employees equal opportunities to develop at the company, and incorporate an equality-centric approach to recruitment, salary, and career development. In accordance with our recruitment policy, the range of candidates is to be based on diversity and equality. However, we always consider the right skills from training and work experience.

Today, Thule has a high attraction value among both men and women. This positive trend has been strengthened for several years through proactive work and a broader product portfolio. Still, it is also growing because more women are graduating from universities and colleges with the skills we require.

**A SUSTAINABILITY PERSPECTIVE ON HEALTH**

By taking a holistic approach to our employees’ lives, we strive to help create conditions that are conducive to a good work-life balance, and support an active lifestyle. Being mentally and physically active and living a healthy life strongly affects how we perform and handle stress.

**ZERO-TOLERANCE POLICY TOWARD HARASSMENT AND DISCRIMINATION**

We have a zero-tolerance policy toward all forms of harassment and discrimination, and our policy against discrimination and harassment specifies how we manage these issues. The local Health & Safety committee handles all reported cases.

**PROCESSES FOR ENGAGING WITH OWN WORKFORCE AND WORKERS’ REPRESENTATIVES ABOUT IMPACTS**

We engage with our employees through employee surveys to ensure follow-up actions are taken and to maintain transparency in its policies and handling of discrimination reports. We systemically monitor and continuously improve processes with a structured approach involving central and local safety committees.

**RESOURCES ALLOCATED**

Intranet, online academy, health and safety training, human rights training, ISO evaluations, and social audits are part of our commitment to standardization in workforce management. We continuously gather data across the Thule organization, on a centralized platform that allows for consistent collection and analysis of workforce metrics such as health and safety, training, diversity, and employee engagement. This centralization fosters transparency and ensures all subsidiaries meet our Group level standards.



Matthias Batthyany, Area Sales Manager Juvenile DACH, Neumarkt, Germany

# Metrics and targets

## Characteristics of the undertaking's Employees

### THE TOTAL NUMBER OF EMPLOYEES BY HEADCOUNT, AND BREAKDOWNS BY GENDER AND BY COUNTRY

Country	Men	Women	Total Number of Employees	Percentage of women
Poland	423	562	985	57.0
Rest of Europe	467	247	714	34.6
North America	197	147	344	42.7
Sweden	416	249	665	37.4
South America	26	10	36	27.8
Australia	73	38	111	34.2
Asia	28	24	52	46.2
<b>Total</b>	<b>1,630</b>	<b>1,277</b>	<b>2,907</b>	<b>43.9</b>

### TOTAL NUMBER OF EMPLOYEES BY HEADCOUNT, BY GENDER

Employees	Male	Female	Not reported	Total
Full time workers on permanent contracts	1,242	933	0	2,175
Workers on temporary contracts	201	151	0	352
Part time workers in permanent contracts	187	193	0	380
Non-guaranteed hours employees	0	0	0	0
<b>Total</b>	<b>1,630</b>	<b>1,277</b>	<b>0</b>	<b>2,907</b>

### EMPLOYEE TURNOVER

Employee turnover	Rate %
Voluntary	5.8
Involuntary	3.4
<b>Total</b>	<b>9.2</b>

### EMPLOYEES SATISFACTION INDEX

Criteria	Satisfaction Index, %
Management	78
Core Values and Goals	81
Climate	75
Organization	78
Working Environment	82
Total Satisfaction Index	78

### WORKERS WHO ARE NOT EMPLOYEES

Work Type	Agency Workers	Consultants	Students	Total
Number of Employees	228	128	33	390

## Collective bargaining coverage and social dialogue

Share of employees covered by collective bargaining agreement or social dialogue in 2024: 70.5%

## Metrics and targets

### Diversity metrics

#### EMPLOYEES BY FUNCTIONS

	Total number	Percentage of women by function, %
<b>Members of the Board</b>		
Total	7	
Men	4	
Women	3	43
<b>CEO &amp; Executive Management</b>		
Total	11	
Men	8	
Women	3	27
<b>Top Management</b>		
Total	73	
Men	48	
Women	25	34
<b>People Leaders and team members</b>		
Total	2,823	
Men	1,574	
Women	1,249	44

#### EMPLOYEES BY AGE AND GENDER

	Men	Men, %	Women	Women, %
Above 50	342	56	270	44
Between 30-50	1,022	57	752	42
Below 30	266	51	255	49
<b>Total</b>	<b>1,630</b>	<b>56</b>	<b>1,277</b>	<b>44</b>

### Adequate Wages

All employees are paid an adequate wage. Thule Group Corporate Governance Manual (TCGM) supports and guides the Group’s internal control in various units in terms of implementing the core values embedded in the Code of Conduct, in relation to working and employment conditions. In our value chain, we minimize human right risks by conducting in-house or third-party audits to ensure that Thule Group fulfill human rights requirements in areas such as living wages, labor, work hours, management, health and safety, freedom of association, and environment.

### Social protection

All employees are covered by social protection against loss of income due to major life events, either through public programs or through benefits offered by the company.

### Training and skills development metrics

Thule offers various programs to improve employees’ skills. Thule Online Academy is a comprehensive online platform through which we offer various trainings. We also provide access to courses offered by third-party suppliers to meet specific requirements; we prioritize continuous competence development of our employees’ skills and knowledge by collaboratively identifying their development needs. This ongoing dialogue ensures that training initiatives are targeted and effective and that we remain an attractive employer. In 2024 81 percent of our employees completed the Human Rights Training.

#### EMPLOYEES WHO PARTICIPATED IN REGULAR PERFORMANCE AND CAREER DEVELOPMENT REVIEWS BY GENDER

	%
Men	91
Women	93

#### THE AVERAGE NUMBER OF TRAINING HOURS PER EMPLOYEE AND BY GENDER

	Hrs/employee
Men	10.0
Women	11.5

#### HUMAN RIGHTS TRAINING PER FUNCTION

	%
Blue Collars	93
White Collars	70

### Remuneration metrics

We are committed to fair and equitable remuneration as a foundation of our employees’ job satisfaction. Additionally, we fully support freedom of association and the right to engage in collective bargaining. Ensuring equal pay for equal work, regardless of gender, is a fundamental commitment for an ethical and responsible company. At our organization, men and women in equivalent roles receive equal pay, supported by clearly defined salary bands across all job categories. We conduct annual reviews to monitor pay equity, comparing salaries between men and women within comparable job bands to ensure ongoing fairness.

#### Pay Gender Pay Gap

In 2024, the aggregated gender pay gap, entry Level is 1.

#### Annual Total Compensation Ratio

The compensation ratio between highest paid executive and the average salary level for the total number of employees 2024 is 14.

#### Methodology

Annual total compensation for the undertaking’s highest-paid individual /median employee annual total compensation (excluding the highest-paid individual).

## Metrics and targets

### Work-life balance

Thule strives to create an inclusive and fair work environment at all its premises worldwide. The benefits offered depend on local regulations and company policy.

PARENTAL LEAVE	
	Number
<b>Total number of employees entitled for parental leave</b>	<b>2,907</b>
Total number of men that took parental leave	120
Total number of women that took parental leave	109

#### Accounting principles and methodologies

100 percent of the company's own workers are entitled to family-related leave through local social policies and/or collective bargaining.

Thule offers full-time employees job security and stability. Some of the benefits that can be offered to full-time employees may include, but are not limited to, the following:

- ▶ **Sick care benefits:** Full-time employees are often covered by health insurance
- ▶ **Parental leave:** Percentage of employees entitled to parental leave, total 100 percent.

### Health and safety metrics

Thule prioritizes health and safety training programs to ensure that all employees possess the necessary knowledge and skills to work safely. 100 percent of Thule's own workforce is covered by the company's health and safety management system based on legal requirements and recognised standards or guidelines.

During 2024, 90 percent of Thule entities were covered by the ISO 45001 management system. Our internal audits also identified areas for improvement and encouraged employees to participate in health and safety activities.

#### Accidents

Accidents are reported monthly on the sustainability digital platform and consolidated annually. We report accidents at our sites that result in losing 8 or more work hours.

- ▶ Annual accident counts by gender for those with 8 or more lost work hours.
- ▶ Annual days lost due to injuries per 1 million work hours.

#### Methodology

Report the annual number of accidents per 1 million work hours.

INJURIES	
	Number
Number of fatalities as a result of work-related injuries and work-related ill health	0
Number and rate of recordable work-related accidents	75
Number of cases of recordable work-related ill health or fatalities	0
Number of cases of recordable work-related ill health, subject to legal restrictions on the collection of data	0
Number of days lost to work-related injuries from work-related accidents, work-related ill health/million hours	207
Rate of work-related injuries	17.27
Working hours	
Total number of working hours	4,342,147
Lost days per million hours worked	207

### Incidents, complaints, and severe human rights impacts

During 2024, we did not have any work related grievance, incidents or complaints.

#### Accounting Principles and methodologies

Thule requires that the following three types of incidents be reported in the sustainability digital platform:

- 1) On-premise or off-premise accidents which result in professional medical treatment and personal injury.
- 2) Cases of harassment.
- 3) Cases of discrimination.

#### INCIDENTS, COMPLAINTS AND SEVERE HUMAN RIGHTS IMPACTS

	Number
<b>Work-related grievances, incidents, and complaints</b>	<b>0</b>
Number of complaints filed through channels for own workers to raise concerns (including grievance mechanisms) to the National Contact Points for OECD Multinational Enterprises	0
Total number of incidents of discrimination, including harassment	0
<b>Severe human rights impacts and incidents</b>	<b>0</b>
Total number of severe human rights incidents connected to the company's workforce	0
Total amount of fines, penalties, and compensation for damages for incidents	0
Reconciliation of the monetary amounts disclosed above with the most relevant amount presented in the financial statements	0

# Workers in the value chain

**46** suppliers were audited in 2024.

**0** cases of forced labor or child labor were identified during 2024.

## ENSURE SAFETY AND A PROPER WORK ENVIRONMENT FOR WORKERS IN THE VALUE CHAIN

At Thule, we are committed to fostering a responsible and sustainable value chain that upholds human rights, ethical practices, and environmental stewardship. Our work is guided and aligned with the U.N Guiding Principles on Business and Human Rights and the OECD Guidelines for Multinational Enterprises.

Our Sustainability Policy, Human Rights Policy, and Supplier Code of Conduct indicate our commitment to comprehensively addressing human rights within our value chain. Thule Group conducts annual CSR audits, focusing on first-tier suppliers in high- and moderate-risk countries, and we select second-tier suppliers based on a yearly risk country analysis. We also prioritize the inclusion of value chain workers through CSR audits, using interviews to gather their perspectives, and ensure that any issues are addressed with corrective actions. This is followed up by implementing corrective actions based on the severity of non-compliance. In 2024, we conducted 46 supplier audits (19 direct suppliers and 20 suppliers from tier 2), including 7 new suppliers. More details page 65.

No cases of forced labor or child labor were identified during 2024.

## HOW WE WORK WITH SUPPLIERS

In 2024 Thule officially launched the Supplier Code of Conduct (SCoC). We are working with suppliers to ensure they align with Thule's key values on human rights, working conditions, and key compliance measures related to supplier due diligence. The SCoC also requires suppliers to ensure forest and water rights in local communities where they operate, and prevent environmental harm to marginalized and vulnerable communities, including forced evacuation using security forces. We also invested in a Supplier Risk Analytics tool for comprehensive screening of risks upstream in the supply chain. Our approach ensures that we make informed, risk-aware sourcing decisions. This tool provides an in-depth supplier data analysis, assessing critical factors such as financial stability, regulatory compliance risk (including human rights), and potential exposure to supply chain disruptions.

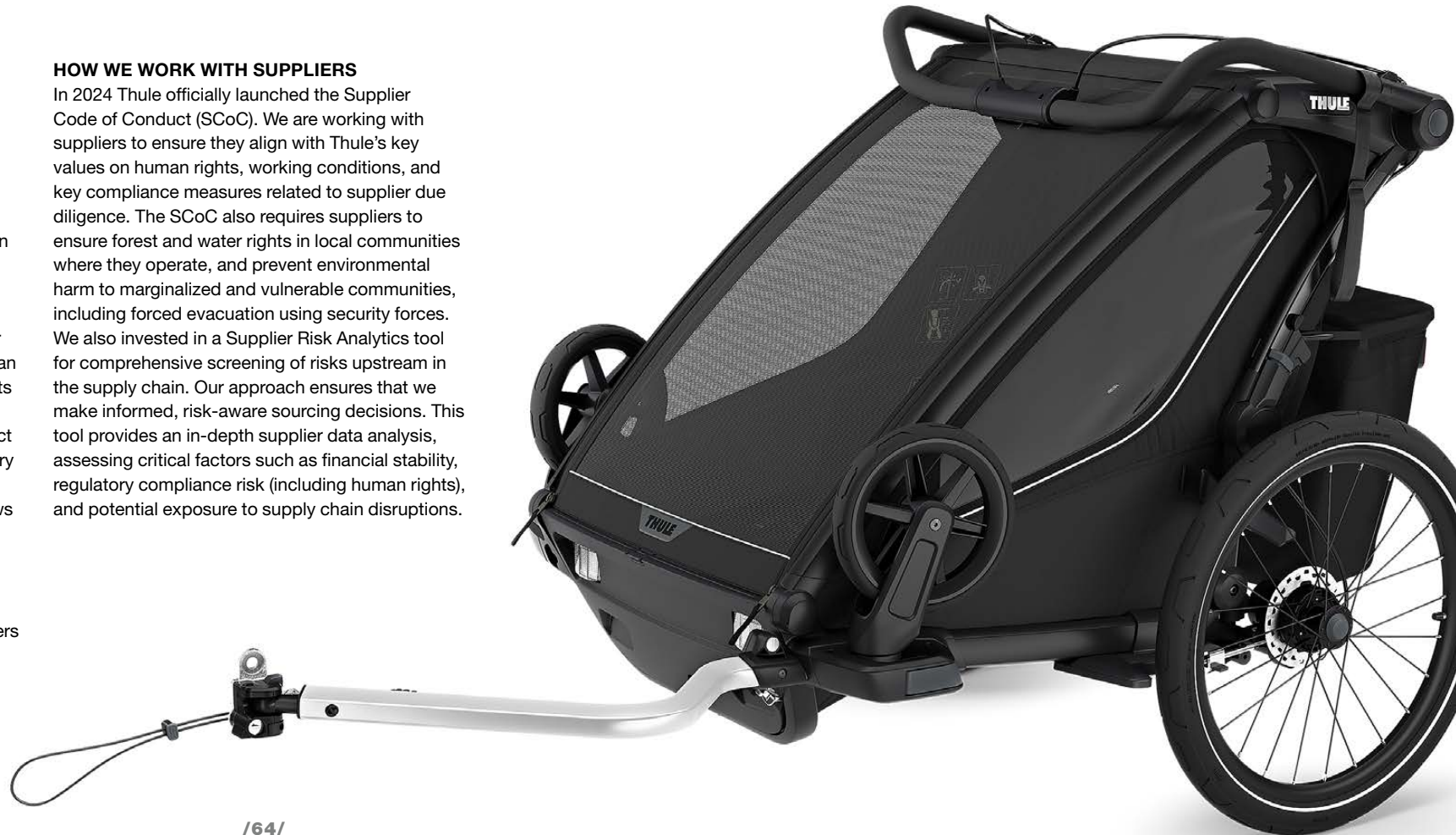

# Metrics and targets

## Managing material impacts

### Negative Impacts & Advancing Positive Impacts

► Ensure suppliers align with Thule’s key values on human rights, working conditions, and key compliance measures related to supplier due diligence.

### Ensuring continuing positive impacts

- Audited suppliers corresponding to 90 percent of purchased spend, in high/moderate-risk countries.
- Audited suppliers corresponding to 99 percent of purchased spend in high/moderate-risk countries with high-risk processes and key product categories.
- 80 percent of suppliers in the Top 80 percent Spend (2024) signed the Supplier Code of Conduct.

### Value Chain Engagement of Suppliers

The assessed Thule tier-1 suppliers demonstrated medium or high impact, risk and opportunities related to the workers in our value chain.

In 2024, we interviewed suppliers representing 21.8 percent of our purchasing spend. The interviewed suppliers are implementing policies and actions to ensure compliance with labor standards and improve working conditions and ensure alignment of their supply chain with their own values and expectations. This includes communicating Supplier Code of Conducts and conducting supplier audits for high-risk regions and for high-risk industrial processes.

### SUPPLIER ASSESSMENT BY COUNTRY

Number of CSR audits/country	Number
China	31
Taiwan	5
Poland	4
India	1
Vietnam	2
Indonesia	2
Romania	1
<b>Total</b>	<b>46</b>

### SUPPLIER AUDITS SCORE

Percentage, %	Number of suppliers
>85	30
71–85	14
51–70	2
<50	0
<b>Total</b>	<b>46</b>

OUR APPROACH AND POLICIES

# Our customer's perspective shape our business



Thule Red Dot Awards Exhibition in Essen.

**Consumer perspectives significantly shape our business strategies and impact management. Our products are sold through various B2B channels through retailers and distributors and directly to consumers through our Thule stores and online in more than 15 countries worldwide on [thule.com](https://www.thule.com)**

**AMBITIOUS PLANS FOR LONG-TERM TARGETS**

Thule has set goals to increase sales by broadening our product range and enhancing visibility by selling more directly to consumers. This ambitious plan comes with risks that we counteract in our strategic planning and daily operations. The highlighted risk categories include labor conditions, health and safety, environmental impact, and customer ethics. Thule has mapped core business processes within the value chain where potential human rights risks may arise, including production, supply chain, sales and distribution (with an emphasis on customer ethics), and corporate governance, covering internal functions like administration, marketing, and finance; read more about our risk analysis from pages 75–81.

**HUMAN RIGHTS POLICY**

Our approach to engaging with consumers and end users is aligned with our Human Rights Policy. Ensuring human rights involves adherence to global human rights principles, health and safety, ethical sourcing, and compliance with environmental and manufacturing standards. We prioritize the safety of our products and the right of people and the environment to be safe from harmful substances and chemicals so people can enjoy an active life outdoors with minimal environmental impact. The company follows the UN Guiding Principles on



Business and Human Rights, the ILO Declaration on Fundamental Principles and Rights at Work, and the OECD Guidelines for Multinational Enterprises. Customers are a key stakeholder for our business, which we ensure to include in our stakeholder dialogues. In our 2024 stakeholder assessment, one of the key areas identified as a priority risk category was customer ethics.

**HOW WE FOLLOW UP ON THE CUSTOMER'S PERSPECTIVE**

Thule integrates ESG initiatives directly into our operations, focusing on sustainable sourcing, carbon reduction, and circular economy practices

to minimize waste and enhance reusability. Transparent ESG reporting and communication with customers has become essential to meet consumer and stakeholder expectations for accountability, boosting brand credibility and loyalty. In addition to our customers' published purchase terms and conditions, Thule has a dedicated consumer service team, and we highly value consumer communications and satisfaction.

**COMMUNICATING WITH OUR CUSTOMERS AND END USERS**

We are also aware of the impact of consumer stories on our brand value, so we prioritize providing multiple

channels for consumers to raise concerns and complaints about our products. We collaborate with independent research organizations such as Mistra Sport and Outdoors, to improve our knowledge and solutions for sustainability in sports and outdoor activities. and we have participated in Mistra's "Toward Sustainable Solutions" project since 2020.

**SAFETY**

Ensuring that our products meet our stringent demands for safety, function, and quality, we conduct state-of-the-art tests in accordance with our Thule Test Program™. Thule is dedicated to SDG 12, promoting sustainable consumption and production

while educating customers on sustainable and safe product use. In line with our commitment to customer satisfaction, we offer limited, extended, and lifetime warranties for our product categories.

Thule provides spare parts and accessories for selected products for a period of up to 5–10 years after the respective warranty period. We also aim to reduce incidents and ensure the longevity of our products by setting internal targets based on historical trends, previous year data, and sales forecasts. As part of our commitment to a circular economy and customer satisfaction, we offer product repair services at our sites in Poland, Germany, Belgium, and the UK.

# Business Conduct



Thule Santu, Thule Epos, Thule Urban Glide 3

## High business ethics are at the core

**Our processes and control systems thoroughly incorporate responsible conduct in all parts of our value chain, in accordance with ambitious ethical values. Legal requirements, rules, and international standards are natural starting points, but our ambition goes further than that. We want to use our company's influence to drive positive development throughout the value chain.**

### FOCUS AREAS

- Audit of high-risk suppliers corresponding to >90 percent of the purchasing volume.
- In-house training programs to increase awareness of human rights risks.

STRATEGY

# Do what's right

At the heart of our work is a dedication to responsible and ethical practices. Our mission goes beyond making an impact; we are committed to fostering positive growth in our business by nurturing ethical behavior and promoting sustainability. With deep care and a passion for growth, we strive to weave these principles into every part of our processes, ensuring we create lasting, positive impacts together.



## Targets

- ▶ Audit of high-risk suppliers corresponding to >90 percent of the purchasing volume (SEK) from these groups on a 12-month basis.

## Policies

- ▶ Code of conduct
- ▶ Human rights policy
- ▶ Anti-Corruption Policy
- ▶ Trade Sanction Policy
- ▶ Competition policy
- ▶ Whistle-blowing manual



More on page 71.

## Day-to-day operations

Manage the company's ethical practices.

Identifying impacts, risks, and opportunities.

Building strong connections with our suppliers.



Thule Ambassador, Apa Sherpa



Thule Caprock

OUR APPROACH AND POLICIES

# Positive influence in the value chain

**We take immense pride in our work, weaving responsible conduct and high ethical values into every aspect of our value chain. While we prioritize legal requirements, regulations, and international standards as essential pillars, we aspire to go beyond just compliance. We aim to use our company's influence to foster positive growth throughout the value chain.**

**RESPONSIBILITY AND OVERSIGHT AT THULE**

Thule's Board of directors is key in guiding our sustainability efforts by establishing our strategic direction, policies, and long-term goals. Meanwhile, the CEO and Group Management focus on recognizing impacts, risks, and opportunities linked to Thule's business strategy and operations. They also ensure compliance and best practices are woven into our sustainability initiatives, including climate action, human rights, health and safety, IT security, privacy, and supply chain due diligence.

Our Board of Directors and the Group Management are responsible for identifying and validating sustainability risks, opportunities, and impacts (IROs) across the entire value chain. This process benefits from the insights gained through our Double Materiality Analysis (DMA), which helps us understand how various sustainability factors, outlined in the European Sustainability Reporting Standards (ESRS), influence Thule's value chain from environmental, social, and financial angles. We also consider how our operations affect the environment and society in general. The DMA adheres to the standards set by the Corporate Sustainability Reporting Directive (CSRD).

The Board has created governance documents to clarify the CEO's roles. Its Rules of Procedure and the Finance Policy outline the internal control quality. The Board reviews operational performance through monthly and quarterly reports that include

outcomes, budget comparisons, forecasts, targets, strategic plans, and financial risk assessments. The CEO keeps the Board informed and ensures an efficient control environment at the Group level. The Board is responsible for the Sustainability Report published annually.

**CORPORATE COMPLIANCE**

Thule’s governing documents details responsibilities and the Group’s legal and ethical duties in anti-corruption, competition, GDPR, and trade sanctions. It is implemented globally, and features structured frameworks, accountability, and regular assessments to promote compliance and ethics. This framework helps maintain core values while setting standards for health and safety, environmental practices, product recalls, risk management, and employment conditions. The governing documents undergo objective evaluations and consistent anti-corruption and legal responsibilities updates.

Thule’s Online Academy requires all employees and board members to train on the Code of Conduct and anti-corruption measures. We have a well-established whistle-blowing function to enable employees, suppliers, and customers to bring possible breaches of the Group’s Code of conduct to the Group’s attention. Technical administration of the whistle-blowing function is done through an external platform, which means, inter alia, that the service can be provided in the notifier’s language.

**SAFETY AND FOSTERING A POSITIVE BUSINESS ENVIRONMENT**

The Board at Thule supports key sustainability governance and due diligence policies, which include the Code of Conduct, Corporate Compliance Program, Sustainability Policy, and Human Rights Policy. Procedures are also in place for recognizing and evaluating risks, and protocols are in place for employees to report suspected violations.

Each year, the Board is informed about the number of whistleblower reports, the types of issues raised, and potential corrective and disciplinary actions taken after investigation. Moreover, our Group Management is dedicated to integrating sustainability into our strategic decisions. We set

targets and strive to meet them while honoring our external sustainability commitments. In addition, the Audit and Sustainability Committee meet quarterly to discuss our sustainability work and reporting.

**SUPPLIER RELATIONS AND DUE DILIGENCE**

To maintain good business conduct, we must ensure good relationships with our suppliers. We have around 750 suppliers across Europe, North America, Asia, and South America. We conduct annual risk assessments of geography, manufacturing, and materials, alongside regular site visits and audits. In 2024, we launched our Supplier Code of Conduct, revising our purchasing policy to include board members, management, employees, suppliers, business partners, subcontractors, and customers.

The Code is based on six principles:

1. Fair business
2. Fair employment
3. Environment
4. Product responsibility
5. Society
6. Property management.

We ensure suppliers adhere to our values regarding human rights, labor conditions, and freedom of speech, including protecting local forest and water rights and preventing environmental harm to vulnerable communities.

Thule ranks suppliers as high, medium, or low risk according to their country of origin, focusing CSR audits on high- and medium-risk nations. The assessment relies on external analyses from Amfori BSCI, Robeco Sam, the Human Freedom Index, and Trafficking in Persons (TIPS) report. Suppliers from high-risk countries with certain manufacturing processes are classified as high-risk.

**SUPPLIER AUDIT**

Thule invested in a supplier risk analytics tool in 2024. This lets us make informed, risk-aware sourcing decisions. The tool provides detailed

supplier data analysis, looking at important factors like financial stability, regulatory compliance risks (including human rights), and potential supply chain issues.

In 2024, 46 suppliers were audited (19 direct suppliers and 20 suppliers from tier 2), including 7 new suppliers. All the audited suppliers implemented corrective measures. If a supplier scores below 50 percent, we limit further purchases from that supplier and conduct a new audit within the next six months.

No cases of forced labor or child labor were identified in 2024.

**FAIR PAYMENT TERMS ARE A MUST**

Paying suppliers on time is crucial, as timely payments ensure sustainability and growth. We have set our payment terms in line with industry practices outlined in our Payment Policy.

**RISK ASSESSMENT**

Risk assessment is part of our daily business. The company conducts continuous risk assessments to identify risks in all areas of operation. A Group level annual Risk Assessment is conducted, reviewed, and approved by the Group Management and the Board of Directors. Read more about Thule Group’s risk assessment process and identified risks on pages 75–81.

The control activity structure is particularly important in preventing and discovering company deficiencies. Risk assessment and control also cover the operational management of each reporting unit, where meetings are held at least six times a year in connection with business review meetings. Thule Group’s CEO, CFO, and local and regional management participate in these meetings.

**HOW WE WORK WITH ANTI-CORRUPTION**

Our business operations are to be conducted according to all applicable laws and regulations and in such a way that high ethical standards are maintained. We do not pursue or accept business benefits based on illegal, inappropriate or unethical behavior. Thule’s position and clear instructions are outlined in the Thule Group Anti-Corruption Manual,

which has been translated into nine languages and published on the website.

Employees who suspect that a violation of anti-corruption laws has occurred at the company are obligated to follow standard reporting procedures. During the year, no incident was reported. Thule identifies corruption risks mainly in sales and procurement due to global operations in 138 countries with over 750 suppliers. We enforce a zero-tolerance policy on unethical behavior, providing employees and partners with mandatory training on the Code of Conduct and anti-corruption laws. Regular audits ensure compliance, along with whistleblower mechanisms for reporting misconduct.

Thule has not had any convictions or fines for violation of anti-corruption and anti-bribery laws during the reporting period.

**WHISTLE-BLOWING PROCESS**

The Board receives whistle-blowing information. The number of whistle-blower reports, kinds of issues, and potential corrective and disciplinary measures, following an investigation, are reported to the Board at least once a year. During 2024, no whistle-blowing incident was reported that resulted in an investigation.



# Annual Report

# Board of Directors' Report



**The Board of Directors and President of Thule Group AB (publ), Corp. Reg. No. 556770-6311, hereby submit the Annual Report and the consolidated financial statements for the 2024 fiscal year.**

## Operations and organization

Thule Group is a global sports and outdoor company that offers high-quality products with smart features and a sustainable design that make it easy for people across the globe to live an active life. Under the motto Bring your life, and with a focus on consumer-driven innovation and long-term sustainability – we develop, manufacture and market products within the product categories Sport&Cargo Carriers (roof racks, roof boxes and carriers for transporting cycling, water and winter sports equipment, and rooftop tents mounted on a car), Juvenile & Pet Products (car seats, strollers, bike trailers, child bike seats and dog transport), RV Products (awnings, bike carriers and tents for RVs and caravans) and Packs, Bags & Luggage (hiking backpacks, luggage and camera bags).

Thule Group has about 2,800 employees at nine production facilities and 35 sales offices worldwide. The Group's products are sold in 138 markets and in 2024, sales amounted to SEK 9.5 billion.

Thule Group is a public limited liability company listed on the Nasdaq Stockholm Large Cap list. The head office is located in Malmö, Sweden.

## Performance of the Group's operations, earnings and position

### NET SALES

For the full-year 2024, net sales amounted to SEK 9,541m (9,132), representing an increase of 4.5 percent. Organically, net sales for the Group rose 3.5 percent. Acquisitions made a positive contribution to net sales of 1.2 percent. Exchange rates had an impact of 0.2 percent.

For the full-year 2024, sales increased despite a challenging market. Growth was driven by many well-received new products and a recovery in certain sections of the bike market.

### OPERATING INCOME

Operating income amounted to SEK 1,522m (1,505), corresponding to a margin of 15.9 percent (16.5). The adjusted operating margin amounted to 17.0 percent after adjustment for transaction costs of SEK 100m in the fourth quarter pertaining to the acquisition of Quad Lock. Operating income was impacted by an improved gross margin. The gross margin amounted to 42.7 percent (40.9). Gross income was positively impacted by a changed product mix, increased volumes and lower material costs. Otherwise, operating income was impacted by higher costs for product launches and high development costs, however, the cost of external inventory management decreased compared to 2023.

## PRODUCT DEVELOPMENT

The main portion of the Group's product development expenses are recognized through profit or loss as an expense as they arise. Expenses mainly comprise development and production of new products. Development expenses amounted to SEK 671m (629) in 2024.

## SEASONAL VARIATIONS

Thule Group's sales and operating income are normally affected by seasonal variations. Sales in the first and fourth quarters are primarily attributable to sales of winter-related products, while sales in the second and third quarters are primarily attributable to summer-related products. Thule Group has adapted its production processes and supply chain in response to these variations. The acquisition of Quad Lock will impact Thule Group's seasonal variations going forward. For additional information, refer to Note 5 Business combinations.

## NET FINANCIAL ITEMS

Net financial items amounted to an expense of SEK 75m (expense: 84). Exchange rate differences on loans and cash and cash equivalents amounted to SEK 20m (21). The external net interest expense for borrowings was SEK 94m (expense: 105).

## SALES TREND BY REGION

### Region Europe & RoW (Rest of World)

In region Europe & RoW, organic growth was 4.7 percent. Sales increased in two out of four product categories – Sport & Cargo Carriers and Juvenile & Pet. In Packs, Bags & Luggage sales were flat. Bike-related products were the main contributors to growth, while RV sales declined due to challenges in the market for new vehicle sales. Several new product launches took place and two new categories – dog products and child car seats – were introduced during the year. In Europe, the expansion of direct-to-consumer (DTC) sales continued, generating growth in all product categories. Own sales via thule.com were launched in five new markets – the Czech Republic, Poland, Finland, Ireland and Portugal. Thule now conducts online sales for 15 European markets via thule.com. During the year, a Thule store was also opened in Munich, Germany. In total, DTC accounted for just over 4 percent of sales in the region.

### Region Americas

In Region Americas, growth was on a par with 2023 (0.1 percent). Sales declined in the categories, Sport & Cargo Carriers and Packs, Bags & Luggage. Sales increased in the Juvenile & Pet category, where a number of new products were launched, and a new category of dog products was introduced. Sales of bike-related products developed positively over

the year despite a negative market trend, mainly due to the successful launch of new products. Sales in North America declined due to a more challenging market, particularly in the US, while sales in Canada and Central and South America developed positively. Market conditions contributed to a negative trend of minus 3 percent in direct-to-consumer (DTC) sales for the year. In total, DTC sales accounted for 15 percent of sales in the region for the year.

**SALES TREND BY PRODUCT CATEGORY Sport&Cargo Carriers**

For the full year, sales increased 5 percent organically. Sales of the largest subcategory of bike carriers reported healthy sales growth during the year with launches of the Thule EasyFold 3 and Thule ReVert bike carriers. Sport&Cargo Carriers accounted for 59 percent of total sales.

**RV Products**

This category has a strong focus on Region Europe & RoW, which accounts for 97 percent of the Group's sales in the category.

For the full year, sales declined 3 percent year-on-year. The RV industry is undergoing a weaker period in which sales to retailers is increasing while

sales to manufacturers is in decline. RV Products accounted for 18 percent of total sales.

RV Products is Thule Group's only product category exposure to a historically cyclical market segment.

**Juvenile & Pet Products**

For the full year, sales increased 10 percent organically year-on-year. A number of product launches took place during the year, leading to healthy sales growth. Two new subcategories were introduced, child car seats and dog products. Thule Allax, a dog transportation crate, and Thule Bexey, a bike trailer for dog transportation, contributed to sales growth. The launch of the Thule Maple and Thule Elm car seats also led to healthy sales growth. The stroller sales trend was driven by the upgraded all-terrain sport stroller Thule Urban Gilde. Juvenile & Pet accounted for 13 percent of total sales. (As of 2025 the category will be named "Active with Kids & Dogs").

**Packs, Bags & Luggage**

For the full year, in Packs, Bags & Luggage, sales declined 2 percent organically year-on-year. Sales have declined for legacy products that are actively being phased out. The Thule brand range posted an

increased sales trend during the year. Packs, Bags & Luggage accounted for 9 percent of total sales.

**Quad Lock**

As from December 4, 2024 Quad Lock was consolidated into Thule Group. As from 2025 the sales will be included in category Packs, Bags & Luggage (which will be renamed "Bags & Mounts").

**FINANCIAL POSITION**

On December 31, 2024, the Group's equity amounted to SEK 8,095m (6,849). Equity was impacted by the dividend of SEK 1,004m resolved on by the 2024 AGM. The equity ratio amounted to 54.1 percent (62.5). The pro forma leverage ratio or net debt:LTM EBITDA (including pro forma EBITDA for Quad Lock corresponding to 12 months) amounted to 1.8 (1.1) as of December 31.

Net debt amounted to SEK 3,961m (2,006) on December 31, 2024. Total long-term borrowing amounted to SEK 4,301m (2,038), comprising loans from credit institutions of SEK 4,164m (1,905), gross, long-term lease liabilities of SEK 150m (128), capitalized financing costs of SEK -21m (2), and the long-term portion of financial derivatives of SEK 7m (7). Total current financial liabilities amounted to SEK 77m (136) and comprised the short-term

portion of financial derivatives and lease liabilities. Net debt increased during the year by SEK 1,955m. Cash flow from operating activities positively contributed with SEK 2,310m, while investments of SEK 3,099m and a dividend of SEK 1,004m had a negative impact.

As of December 31, 2024, goodwill totaled SEK 7,417m (4,857). The acquisition of Quad Lock has increased goodwill recognized by SEK 2,327m. For more information, see Note 5 Business combinations.

As of December 31, 2024, deferred tax receivables amounted to SEK 359m (281), of which SEK 145m (120) pertained to capitalized loss carry forwards.

**CASH FLOW**

Cash flow from operating activities for the full-year 2024 was SEK 2,310m (1,850). Inventories declined SEK 492m compared with the start of the year. Investing activities were impacted by acquisitions amounting to a net SEK 2,837m and investments in tangible and intangible assets amounting to a net SEK 263m (251).

The Group's cash and cash equivalents at year end totaled SEK 405m (94). Moreover, the Group also has unutilized, binding loan commitments of

SEK 2,105m (2,288) to finance the ongoing operations.

For more information about terms of the loans, see Note 23.

**Parent Company**

Thule Group AB's principal activity pertains to head office functions such as Group-wide management and administration. The comments below refer to the period January 1–December 31, 2024. The Parent Company invoices its costs to Group companies. The Parent Company reported net income of SEK 579m (634). Cash and cash equivalents and current investments amounted to SEK 0m (0). Long-term liabilities to credit institutions totaled SEK 4,143m (1,903).

The Parent Company's financial position is dependent on the financial position and development of its subsidiaries. The Parent Company is therefore indirectly impacted by the risks described in the Risks and risk management.

**Significant events during the fiscal year**

**ACQUISITIONS**

At the start of July, Thule Group acquired the German company Reacha (good goods tegernsee GmbH). The company has an innovative product design that makes it possible for people to cycle to the sea or lake with a kayak, surfboard or stand up paddleboard (SUP) carried on a bike trailer. Operations are based in Germany with the majority of sales in Europe. The company had sales of about SEK 9m in 2023 and the purchase consideration was about SEK 11m (including net debt) with the possibility of an earn-out payment of a maximum of SEK 4m based on the outcome for 2024.

Bike trailers is an attractive and growing segment. Operations will be integrated in Thule's product portfolio and distribution channels. Reacha was consolidated into Thule Group as of July 2024.

SHARE OF SALES PER PRODUCT CATEGORY		
%	2024	Growth vs 2023 <sup>1</sup>
Sport&Cargo Carriers	59	5
RV Products	18	-3
Packs, Bags & Luggage	9	-2
Juvenile & Pet	13	10
Quad Lock	1	n.a.

1) Adjusted for changes in exchange rates and acquisitions

NET DEBT		
SEKm	Dec 31, 2024	Dec 31, 2023
Long-term loans, gross	4,315	2,033
Financial derivative liability, long-term	7	7
Short-term loans, gross	75	99
Financial derivative liability, short-term	2	34
Overdraft facilities	0	3
Capitalized financing costs	-21	-2
Accrued interest	2	1
<b>Gross debt</b>	<b>4,380</b>	<b>2,175</b>
Financial derivative assets	-15	-75
Cash and cash equivalents	-405	-94
<b>Net debt</b>	<b>3,961</b>	<b>2,006</b>

On December 4, the Group completed the acquisition of 100 percent of the shares and votes of the unlisted company Key TopCo Pty Ltd, the owner of Quad Lock. Quad Lock is the global market leader in performance phone mount solutions, giving cyclists, motorcyclists, and other adventurers access to their mobile phones while being active.

The purchase consideration was based on a valuation of AUD 500m, or approximately SEK 3.6 billion, on a cash and debt free basis. The purchase consideration corresponds to a multiple of 10x Quad Lock's LTM EBITDA. The transaction was financed through a combination of existing cash and credit facilities (approximately 76 percent of the purchase consideration), newly issued shares in Thule Group (approximately 24 percent), see Note 5 Business combinations.

Quad Lock was founded in 2011 when its two Australian founders invented a wear-resistant and user-friendly solution to easily mount cellphones on their mountain bikes. The product offering has been expanded at a rapid pace and, today, Quad Lock is the global market leader in performance phone mounts with the market's largest selection of high-quality and robust solutions for enthusiasts of all-terrain biking, motorcycling or driving. Quad Lock has sales in approximately 100 countries, of which about 75 percent are via e-commerce direct to consumers. The head office is based in Melbourne, Australia. Quad Lock was consolidated into Thule Group as of December 4, 2024.

### NEW FINANCING AGREEMENT

A new, EUR 550m financing agreement was entered during the year and comprises a combination of a revolving credit facility (RCF) of EUR 470m and a long-term loan of EUR 80m. The RCF comprises two tranches of equal amounts with maturities of three and five years, and options for extension of up to two years. The long-term loan has a maturity of four years. The new RCF facility is provided in equal shares by Nordea Bank Abp, Swedish branch; Swedbank AB (publ); Danske Bank A/S, Swedish branch; and DNB Bank ASA, Swedish branch. Nordea Bank Abp, Swedish branch, acts as a proxy and coordinator for the transaction in its role as

documentation proxy. The lender for the long-term loan is AB Svensk Exportkredit (SEK). In conjunction with the new financing agreement entering force, the existing loans under the old loan agreement were repaid. The new financing agreement secured flexible, long-term financing for the company and has a diversified term structure.

## Risks and risk management

Like all business operations, Thule Group's operations are associated with different types of risk. Continuously identifying and evaluating risks is a natural and integrated part of the work approach, thus enabling us to control, limit and manage prioritized risks in a proactive manner. The Group's ability to identify, map and prevent risk reduces the likelihood of adverse events having a negative impact on the company's operations. The goal of risk management is not necessarily to eliminate risk, but rather to safeguard meeting our business goals by way of a balanced risk portfolio.

Identifying, mapping, planning and managing identifiable risks all support management when taking strategic decisions. The risk assessment also aims to increase risk awareness across the entire organization, both for operational decision-makers and for the Board.

### ORGANIZATION

The Board of Directors of Thule bears ultimate responsibility for the company's risk management. Risks relating to business development, long-term strategic planning, sustainability initiatives are managed and prepared by way of a prioritization proposal produced by Group management, and prioritized ultimately by the Board. Prioritization is also allocated according to the assessed likelihood and level of impact should the risk materialize.

Group management reports ongoing risk issues such as the Group's financial status and compliance with the Group's finance policy to the Board. The Group's central finance department is responsible for the prioritization and management of financial risks.

Thule Group has a central function responsible for ensuring that the Group is appropriately protected by insurance for insurable risks. The Group's Code of Conduct and a number of more specific policies form the basis of ongoing operational risk management undertaken at every level of the organization.

### RISK OVERVIEW

A number of risk areas have been identified in Thule's risk management process. The tables briefly describe the most significant risks, along with their counteracting factors and management, to limit their potential impact on operations. Each of these risks is also assessed according to the likelihood and level of impact should the risk materialize. These assessments are presented using a graded scale for each of the risks.

The Group management evaluates and manages the primary risks in operations relate to a time frame of 1–3 years. A more detailed compilation of financial risks can be found in Note 4 on pages 101–103.

Thule has categorized identified risks as Product design and development, Supply chain and sourcing, External factors and market risks, Production and operations, Financial risks, Human resources and workplace conditions, Policy risks and Corporate governance.

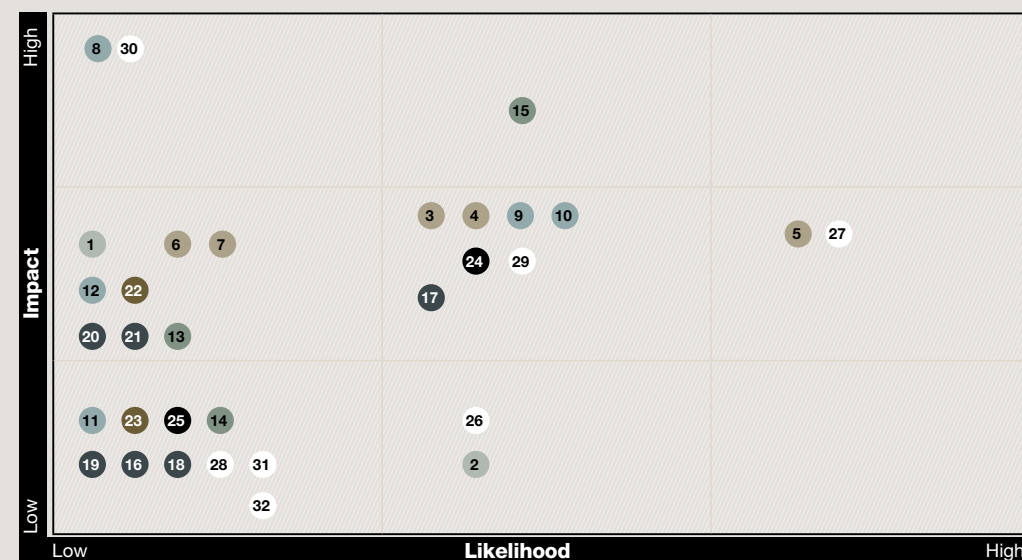

<b>Product design and development</b>
1 Product quality and safety
2 Increased requirements on product transparency, Product Environmental Footprint and related regulatory compliance
<b>Supply chain and sourcing</b>
3 Supply chain disruptions
4 Dependency on external suppliers
5 Increased volume of shipments
6 Violation of human rights
7 Commodity price risk
<b>External factors and market risks</b>
8 Lowered demand for underlying products
9 Climate change impacts
10 General business cycle and its impact on demand
11 Competition
12 Reputation
<b>Production and operations</b>
13 Transitional risks involved in decarbonization of sites
14 Environmental management of Thule sites
15 Deficiencies in health and safety

<b>Financial risks</b>
16 Interest rate risk
17 Exchange rate risk
18 Refinancing and liquidity risk
19 Credit risk
20 Insurance risks
21 Financial regulatory risks
<b>Human resources and workplace conditions</b>
22 Inability to retain and recruit qualified personnel and executive management
23 Deficiencies in gender equality, diversity and discrimination
<b>Policy risks</b>
24 Policy compliance
25 Competition Legislation
<b>Corporate governance</b>
26 Local business in countries with operations
27 Disruption to critical IT systems, business processes and other digital infrastructure, and cyber security risks
28 Patent
29 Taxes
30 Deficiencies in sustainability efforts
31 Corruption and bribery
32 Responsible Marketing

# Risks and risk management

Likelihood	Impact
High	
Medium	
Low	

RISK CATEGORY	DESCRIPTION OF RISK	LIKELIHOOD IMPACT	LINK TO ESRS	COUNTERACTING FACTORS AND MANAGEMENT
<b>● Product design and development</b>				
<b>PRODUCT QUALITY AND SAFETY</b>	<ul style="list-style-type: none"> <li>▶ Thule offers many products intended for use in urban environments, on the roads and in nature. These products are exposed to extreme stress. If any failures or faults were to arise in the products, this could result in damage to property or in the worst case people.</li> <li>▶ The Juvenile &amp; Pet Product Category is growing steadily with more products. A growing portfolio of products for children also increases the risk of product safety issues, as well as the need to take extra precaution with chemical compliance.</li> </ul>		<a href="#">E-2</a>	<ul style="list-style-type: none"> <li>▶ Thule complies with all laws and regulations that apply to the development and testing of the products in development.</li> <li>▶ Thule Group implements detailed failure mode effect analyses (FMEAs) for all new products in development. Possible risks and their potential negative consequences are evaluated and defined in these analyses.</li> <li>▶ Thule Group conducts extreme tests pursuant to Thule Test Standards. The requirements under Thule Test Standards are as or more stringent than the requirements contained in the relevant product safety regulations.</li> <li>▶ Thule conducts a detailed follow-up on quality levels at suppliers and in their own assembly plants, and follow-up and manages any end-user complaints.</li> <li>▶ Thule Group regularly invests significant resources in its own Thule Test Center, where all of the company's products are tested during development and as finished products.</li> </ul>
<b>INCREASED REQUIREMENTS ON PRODUCT TRANSPARENCY AND PRODUCT ENVIRONMENTAL FOOTPRINT (PEF), AND RELATED REGULATORY COMPLIANCE</b>	<ul style="list-style-type: none"> <li>▶ Requirements on product sustainability are a potential risk, as lower emission materials, or materials that have third party certifications on chemical and data are most costly, and liable for more product compliance requirements. Moreover, increasingly recycled content depends on the cost and availability of materials.</li> </ul>		<a href="#">E-2</a> <a href="#">E-5</a>	<ul style="list-style-type: none"> <li>▶ Thule conducts life cycle assessments of product materials, using a cradle to gate approach, and implements ecodesign principles that are integrated across different checkpoints of the R&amp;D and product design and development stages. We also work with our suppliers to procure lower emission materials, work towards getting supplier data on materials, and we have implemented a Restricted Substances List that is in accordance with the REACH Regulation, applicable to all our business partners.</li> </ul>
<b>● Supply chain and sourcing</b>				
<b>SUPPLY CHAIN DISRUPTIONS</b>	<ul style="list-style-type: none"> <li>▶ Thule works with external suppliers primarily from Europe, Asia and North America. Any disruption in the logistics chain for raw material or component goods in our own production, finished products produced by suppliers or in deliveries from Thule Group to customers could adversely impact the Group's delivery commitments and sales.</li> <li>▶ Several supply chains have faced significant pressures and capacity challenges in recent years. These risks delaying supplier deliveries to Thule Group as well as from the Group to customers.</li> </ul>		<a href="#">E-5</a> <a href="#">S-2</a>	<ul style="list-style-type: none"> <li>▶ Thule collaborates closely with suppliers and freight forwarders, which enables the Group to be well-prepared and able to manage the risk of temporary supply-chain disruptions.</li> <li>▶ Thule's proven flexibility in its supply chain entails a very high degree of adaptability.</li> <li>▶ Thule's assembly facilities are strategically located close to the Group's main markets, which reduces exposure to supply chain risks for product deliveries to the Group's customers.</li> <li>▶ Equally, a large proportion of Thule Group's suppliers are geographically located close to the Group's facilities, which increases flexibility and reduces the risk of supply chain challenges.</li> </ul>
<b>DEPENDENCY ON EXTERNAL SUPPLIERS</b>	<ul style="list-style-type: none"> <li>▶ Thule purchases products and components from 750 suppliers around the world. In order to be able to manufacture, sell and deliver products, Thule Group is dependent on external suppliers. If these suppliers are affected by financial, legal or operations-related problems, this could in turn result in adverse impacts on Thule Group's deliveries. Deficiencies in quality and performance from suppliers can lead to consequences for Thule's products, their sustainability and safety-in-use for consumers.</li> </ul>		<a href="#">S-2</a>	<ul style="list-style-type: none"> <li>▶ Thule conducts regular assessments of the status of external suppliers in order to predict and prepare its business and production for any potential changes.</li> <li>▶ Thule continuously monitors changes in relevant regulations.</li> <li>▶ Clear requirement specifications for external suppliers are used to assure follow-up of quality and business-related risks.</li> <li>▶ We have our own dedicated quality organization (Supplier Quality), which maintains regular contact with and inspection of external suppliers, including physical meetings for local follow-up.</li> <li>▶ Thule Group conducts regular tests of purchased material and our suppliers' products. These tests are performed both internally and with assistance from external parties.</li> </ul>

Supply chain and Sourcing, cont.

Likelihood	Impact
High	
Medium	
Low	

RISK CATEGORY	DESCRIPTION OF RISK	LIKELIHOOD IMPACT	LINK TO ESRS	COUNTERACTING FACTORS AND MANAGEMENT
<b>INCREASED VOLUME OF SHIPMENTS</b>	<ul style="list-style-type: none"> <li>▶ The company's products are sold in 138 markets. Overall, this inevitably entails the transportation of goods and components. The direct and indirect use of transportation services often involves the use of fossil fuels. A strained global logistics chain entails a risk of forcing more transportation to be conducted using energy-intensive modes of transport.</li> <li>▶ An increased share of direct to customer (DTC) sales through Thule's own online channel means an increased number of short-distance shipments</li> </ul>		<a href="#">E-1</a>	<ul style="list-style-type: none"> <li>▶ Thule works to optimize necessary logistics flows.</li> <li>▶ When procuring transportation services, emissions requirements constitute a vital parameter.</li> <li>▶ Thule Group's assembly and warehouse facilities are strategically located close to the Group's main markets, helps optimize the company's logistics flows.</li> </ul>
<b>VIOLATION OF HUMAN RIGHTS</b>	<ul style="list-style-type: none"> <li>▶ We have over 750 suppliers located around the world. In some countries, insights into human rights may be limited. This entails a risk that the company could involuntarily contribute to violations of human rights.</li> </ul>		<a href="#">S-2</a>	<ul style="list-style-type: none"> <li>▶ Thule is a participant in the UN Global Compact and therefore abides by its ten principles.</li> <li>▶ The company's global Code of Conduct applies to all of Thule Group's Board members, senior executives.</li> <li>▶ We require our suppliers to adhere to our Human Rights Policy and Supplier Code of Conduct, with strict requirements on human rights due diligence. We also conduct audits on 90 percent of our rolling 12 month spend, on suppliers based in high risk countries. High risk suppliers are determined based on an annual risk assessment, that screens suppliers based on risk associated with their geographical location, materials they supply to Thule, and spend.</li> <li>▶ Thule supplier strategy includes the company's sustainability aspects (including Group Management), employees and, to the greatest extent possible, suppliers, business partners, sub suppliers and customers.</li> <li>▶ Thule conducts CSR audits, both in-house and in partnership with the company Intertek.</li> </ul>
<b>COMMODITY PRICE RISK</b>	<ul style="list-style-type: none"> <li>▶ For the Group, it is primarily fluctuations in plastic, aluminum and steel prices that constitute a significant commodity price risk. The introduction of tariffs increases the risk of fluctuating commodity prices.</li> </ul>		<a href="#">S-2</a>	<ul style="list-style-type: none"> <li>▶ The commodity price risk is managed through supplier contracts and through financial commodity contracts with terms of up to one year.</li> </ul>

**External factors and market risks**

<b>LOWERED DEMAND FOR UNDERLYING PRODUCTS</b>	<ul style="list-style-type: none"> <li>▶ In some cases, demand for Thule's range is dependent on demand for other underlying products. If such demand should change, it could entail an adverse impact on Thule Group's earnings.</li> </ul>		<a href="#">S-4</a>	<ul style="list-style-type: none"> <li>▶ Thule consistently monitors consumer trends and developments in adjacent industries to which the Group has a link, and is accustomed to quickly adapting to new trends, demand and needs.</li> <li>▶ Thule Group's proven flexibility in its purchasing and logistics organization entails a very high degree of adaptability</li> </ul>
<b>CLIMATE CHANGE IMPACTS</b>	<ul style="list-style-type: none"> <li>▶ Over a longer time horizon, if climate change impacts are unmitigated, the impacts can potentially hinder opportunities to enjoy an active life in terms of, for example, skiing in an alpine environment or water sports in polluted watercourses.</li> </ul>		<a href="#">E-1</a>	<ul style="list-style-type: none"> <li>▶ Thule works with SBTi targets, both in our own operations, and with our supply chain keeping our work aligned with the Paris Agreement to not exceed the global temperature by 1.5 degrees.</li> <li>▶ We work with our suppliers and customers to manufacture products with low climate impact, and we continuously renew our product portfolio, so that we are aligned with trends and market pattern, as well as to identify opportunities to live an active life.</li> <li>▶ We work with several interest organizations to advance our interests of living an active life, and our aim is that by continued collaborative efforts, that we mitigate climate impacts so that the planet continues to be a source of inspiration for people to live an active life outdoors.</li> </ul>

External factors and market risks, cont.

Likelihood	Impact
High	
Medium	
Low	

RISK CATEGORY	DESCRIPTION OF RISK	LIKELIHOOD IMPACT	LINK TO ESRS	COUNTERACTING FACTORS AND MANAGEMENT
<b>GENERAL BUSINESS CYCLE AND ITS IMPACT ON DEMAND</b>	<ul style="list-style-type: none"> <li>▶ Changes in the business cycle, as well as interest rate changes and inflation, that lead to reduced spending power may have a negative effect on Thule Group's earnings.</li> <li>▶ Higher tariff rates imposed on Thule products in different countries can incur high import costs for Thule but can also increase the price of the product for consumers.</li> <li>▶ A changing global security situation can lead to declining optimism among consumers around the world, which can lead to reduced interest in purchasing Thule products and thereby have a negative impact on Thule's earnings.</li> <li>▶ RV Products is the Group's only cyclical product category, since purchases of products in this category normally coincide with the purchase of the vehicle (RV or caravan), which comprises a substantial financial investment for the consumer.</li> <li>▶ In 2024, the product category was negatively impacted by increased costs for financing purchases due to higher interest rates around the world.</li> </ul>			<ul style="list-style-type: none"> <li>▶ Thule has sales in 138 markets, thereby reducing the impact risk of an event in any one market.</li> <li>▶ The sports and outdoor industry's historically relatively limited exposure to rapid fluctuations during the business cycle allows time for adaptation.</li> <li>▶ Thule's various product areas means reduced exposure to impact from the economic cycle.</li> <li>▶ Thule purchasing, manufacturing and retailing organization has proven flexibility, resulting in a very high degree of adaptability Thule Group participates in several interest organizations and follows developments closely.</li> <li>▶ Thule Group continuously renews its product portfolio to be able to follow trends in terms of consumer patterns as well as opportunities to carry out activities and live an active life.</li> </ul>
<b>COMPETITION</b>	<ul style="list-style-type: none"> <li>▶ Thule's operations are exposed to competition. If this competition should increase, it could have an adverse impact on Thule Group's earnings.</li> </ul>		<a href="#">S-4</a> <a href="#">E-5</a>	<ul style="list-style-type: none"> <li>▶ Activities such as product development, quality work and prize-winning designs as well as proven security of supply and comprehensive sustainability efforts, are focused on maintaining the Group's market position and strengthening its competitiveness.</li> </ul>
<b>REPUTATION</b>	<ul style="list-style-type: none"> <li>▶ Thule's sales and results are to a large degree dependent on the Group's reputation remaining positive.</li> </ul>		<a href="#">S-1</a> <a href="#">S-4</a>	<ul style="list-style-type: none"> <li>▶ Thule conducts continuous preventative work by providing training and information about the Group's Code of Conduct. Procedures are in place encompassing how the products are developed and tested as well as how we ensure compliance with competition law and sustainability matters.</li> <li>▶ The Group's quality work is certified in line with ISO 9001:2015 and in 2024 will be certified in line with ISO 45001.</li> <li>▶ Thule Group has an established product recall policy in place with clear procedures and established steps for escalation and decision.</li> </ul>

## ● Production and operations

<b>TRANSITIONAL RISKS INVOLVED IN DECARBONIZATION OF SITES</b>	<ul style="list-style-type: none"> <li>▶ Meeting Group level Scope 1 targets requires decarbonization of sites that have transitional risks.</li> </ul>		<a href="#">E-1</a>	<ul style="list-style-type: none"> <li>▶ Thule is investing in site decarbonization of selected sites with technical and cost feasibility studies, and assessment of alternative options, including market readiness and policy requirements.</li> </ul>
<b>ENVIRONMENTAL MANAGEMENT OF THULE SITES</b>	<ul style="list-style-type: none"> <li>▶ Increased production leads to an increase in overall environmental impact related to the manufacture and distribution of the Group's products, specifically on higher energy consumption, increased emissions, impacts on water consumption and waste generation.</li> <li>▶ Mismanagement of environmental impacts on energy, waste, water, emissions, pollution, as well as use of chemicals could lead to known, as well as currently unknown, clean-up costs could impact Thule Group's operations, earnings and reputation.</li> </ul>		<a href="#">E-1</a> <a href="#">E-2</a> <a href="#">E-3</a> <a href="#">E-5</a>	<ul style="list-style-type: none"> <li>▶ Thule conducts systematic work to reduce the Group's general environmental impact and to ensure the group's operations are conducted in compliance with relevant environmental legislation and other environmental provisions.</li> <li>▶ Thule pursues comprehensive quality and environmental management initiatives that impose requirements both on our own production and on that conducted by suppliers. As part of these efforts, the Group is gradually certifying all production facilities under the ISO 14001:2015 framework. The current status is always updated on the Group's website <a href="http://www.thulegroup.com/en/certificates">www.thulegroup.com/en/certificates</a>.</li> </ul>

Production and operations, cont.

Likelihood	Impact
High	
Medium	
Low	

RISK CATEGORY	DESCRIPTION OF RISK	LIKELIHOOD IMPACT	LINK TO ESRS	COUNTERACTING FACTORS AND MANAGEMENT
<b>DEFICIENCIES IN HEALTH AND SAFETY</b>	<ul style="list-style-type: none"> <li>▶ The work environment, health and safety are central focus areas for Thule.</li> <li>▶ Deficiencies in safety and the work environment entail an increased risk of ill health and incidents for the Group's employees.</li> </ul>		<a href="#">S-1</a>	<ul style="list-style-type: none"> <li>▶ Thule Group conducts systematic work to safeguard and improve the work environment.</li> <li>▶ Thule Group continuously monitors a number of parameters within the area of health and safety. Opportunities for improvements are discussed in the central and local Safety Committees. Improvements are continuously implemented and debriefed.</li> </ul>

## Financial risks

<b>INTEREST RATE RISK</b>	<ul style="list-style-type: none"> <li>▶ Interest rate risk is the risk that the value of financial instruments fluctuates due to changes in market interest rates and the risk that changes in the interest rate level will impact the Group's borrowing costs.</li> </ul>			<ul style="list-style-type: none"> <li>▶ This interest rate risk is managed by the Group's central finance department, which adheres to the company's finance policy. The finance policy stipulates the use of lock-in periods, and the tool mainly comprises interest rate swaps.</li> </ul>
<b>EXCHANGE RATE RISK</b>	<ul style="list-style-type: none"> <li>▶ Thule is active internationally and exposed to exchange rate risk that arise from various currency exposures, mainly with respect to EUR/SEK, for which the Group has a positive net inflow.</li> <li>▶ Exposure stems from transaction exposure as well as translation exposure.</li> </ul>			<ul style="list-style-type: none"> <li>▶ The central finance department is responsible for all hedging to reduce the effect of transaction exposure.</li> <li>▶ The Group's policy with regard to translation exposure, is to hedge current net investments for each currency with loans in the same currency to the extent possible.</li> </ul>
<b>REFINANCING AND LIQUIDITY RISK</b>	<ul style="list-style-type: none"> <li>▶ Refinancing risk refers to the risk that Thule Group is unable to refinance its operations at the desired moment, or that the cost of refinancing increases.</li> <li>▶ Liquidity risk refers to the risk that Thule Group is unable to fulfill its payment commitments.</li> </ul>			<ul style="list-style-type: none"> <li>▶ The central finance department continuously monitors whether Thule Group is fulfilling the binding key figures linked to the company's loan facilities.</li> <li>▶ The Group has a rolling eight-week liquidity plan that includes all divisions of the Group. The plan is updated monthly.</li> </ul>
<b>CREDIT RISK</b>	<ul style="list-style-type: none"> <li>▶ Credit risk is the risk that Thule Group's counterparties are unable to pay their liabilities and thereby cause losses for Thule Group.</li> </ul>			<ul style="list-style-type: none"> <li>▶ Customers undergo credit checks in accordance with the Group's credit policy and outstanding balances are monitored continuously.</li> </ul>
<b>INSURANCE RISKS</b>	<ul style="list-style-type: none"> <li>▶ Insurance risks refer to potential difficulties signing adequate insurance protection to cover potential financial losses and liabilities associated with different aspects of Thule Group's operations that could be mitigated through insurance protection. The major insurance protection for Thule Group is insurance for product liability, and property and business interruption insurance.</li> </ul>			<ul style="list-style-type: none"> <li>▶ Through continuous internal and external evaluations of potential insurable risks, as well as close partnerships with expertise in the area, Thule Group maintains focus on its operations to identify potential risks and to customize insurance protection that provides adequate protection against the defined risks.</li> <li>▶ Insurance protection is usually renewed annually.</li> </ul>
<b>FINANCIAL REGULATORY RISKS</b>	<ul style="list-style-type: none"> <li>▶ Operations at Thule Group generate financial transactions, which need to follow established regulatory requirements in each market. If Thule Group fails to follow established laws and regulations, there is a risk for financial and legal consequences for the company.</li> <li>▶ Financial, acquisition related and legal consequences for the company entail risks for the company's operations, financial stability and reputation.</li> </ul>			<ul style="list-style-type: none"> <li>▶ Thule Group regularly updates its policies and procedures for financial transactions and performs basic risk assessments when conducting financial transactions.</li> <li>▶ Thule Group partners with expertise to stay informed about changes in regulation compliance.</li> <li>▶ The company regularly holds training to ensure that employees are aware of, and follow, applicable regulations.</li> <li>▶ Internal follow-up and evaluation is conducted according to Thule Group's Code of Conduct.</li> <li>▶ External follow-up and evaluation is performed through bank procedures and disclosures in connection with Know Your Customer (KYC) and Anti-Money Laundering (AML).</li> </ul>

Likelihood	Impact
High	
Medium	
Low	

RISK CATEGORY	DESCRIPTION OF RISK	LIKELIHOOD IMPACT	LINK TO ESRS	COUNTERACTING FACTORS AND MANAGEMENT
---------------	---------------------	-------------------	--------------	--------------------------------------

## ● Human resources and workplace conditions

<b>INABILITY TO RETAIN AND RECRUIT QUALIFIED PERSONNEL AND EXECUTIVE MANAGEMENT</b>	<ul style="list-style-type: none"> <li>▶ Being able to attract and retain qualified personnel and its executive management is vital to Thule Group's future operations.</li> </ul>		<u>S-1</u>	<ul style="list-style-type: none"> <li>▶ By promoting career development and other development opportunities for employees while offering market-rate and competitive remuneration, we safeguard our ability to attract the right resources and ensure that employees choose Thule Group as a long-term employer because they thrive and develop in the environment provided by the company.</li> <li>▶ The risk of dependency on seasonal staff is reduced through increased automation, primarily of assembly lines.</li> </ul>
<b>DEFICIENCIES IN DIVERSITY AND INCLUSION</b>	<ul style="list-style-type: none"> <li>▶ Deficiencies in the implementation of and compliance with Thule Group's core values could lead to deficiencies in gender equality and diversity.</li> <li>▶ Deficiencies in the right to organize can lead to conflicts with labor organizations as well as public opinion.</li> </ul>		<u>S-1</u>	<ul style="list-style-type: none"> <li>▶ Thule conducts recurring in-depth employee surveys and actively follows up on these results.</li> <li>▶ The work is conducted with full transparency in relation to policies, employee manuals and the reporting of breaches related to discrimination.</li> <li>▶ Thule Group has a well-established whistle-blowing function to enable employees, suppliers and customers to bring possible breaches of the Group's Code of Conduct to the Group's attention. Technical administration of the whistle-blowing function is through an external platform, which means, inter alia, that the service can be provided in the notifier's own language.</li> </ul>

## ● Policy risks

<b>POLICY COMPLIANCE</b>	<ul style="list-style-type: none"> <li>▶ Regulatory compliance in relation to relevant international and EU laws and other provisions are requisite to avoiding penalty fees and other sanctioning measures. There are several environmental laws and directives, including laws on supply chain, carbon emissions, and other aspects such as trade sanctions that can affect Thule's financial position.</li> </ul>		<u>E-1</u> <u>E-2</u> <u>S-4</u> <u>G-1</u>	<ul style="list-style-type: none"> <li>▶ Thule is stringent with observing the policy landscape, in terms of existing or emerging regulations, -compliance requirements, as well as other relevant laws and provisions that can impact the business, or product requirements. We are equipped with the knowledge and operative skills to navigate and implement regulations and requirements.</li> </ul>
<b>COMPETITION LEGISLATION</b>	<ul style="list-style-type: none"> <li>▶ Thule Group's guidelines on competition legislation can be contravened.</li> <li>▶ Thule Group's strong position in certain product categories and in some markets may entail restrictions on acquisitions and other business decisions.</li> </ul>		<u>G-1</u>	<ul style="list-style-type: none"> <li>▶ Thule works continuously with training employees in the relevant legislation and regulations.</li> <li>▶ Thule conducts continuous internal audits.</li> <li>▶ Thule engages expert legal support in cases of uncertainty.</li> </ul>

## ○ Corporate Governance

<b>LOCAL BUSINESS RISKS IN COUNTRIES WITH OWN OPERATIONS</b>	<ul style="list-style-type: none"> <li>▶ Thule Group's business is subject to local laws and regulations in countries where the Group operations are active.</li> <li>▶ Violation of local laws and regulations could impede the Group's investments and result in increased costs.</li> </ul>		<u>G-1</u>	<ul style="list-style-type: none"> <li>▶ Thule's Code of Conduct is comprehensive and regulates local behavior. At the same time, Thule Group also implements various preventive measures to further reduce the risk of regulatory non-compliance.</li> </ul>
--	--	--	------------	---

Corporate governance, cont.

	Likelihood	Impact
High		
Medium		
Low		

RISK CATEGORY	DESCRIPTION OF RISK	LIKELIHOOD IMPACT	LINK TO ESRS	COUNTERACTING FACTORS AND MANAGEMENT
<b>DISRUPTION TO CRITICAL IT SYSTEMS, BUSINESS PROCESSES AND OTHER DIGITAL INFRASTRUCTURE, AND CYBER SECURITY RISKS</b>	<ul style="list-style-type: none"> <li>Disruption or failures in critical IT systems can directly impact production, logistics and our own online sales (DTC) for example, thereafter, leading to the risk of shortcomings relating to the delivery of products or information to customers and other stakeholders Shortcomings pertaining to data protection can also lead to business-critical data becoming accessible to unauthorized parties.</li> <li>External breaches of the Group's IT environment entail increased risk of data loss, fraud and other irregularities.</li> </ul>			<ul style="list-style-type: none"> <li>The company has a structured Group-wide responsibility for IT security. The work follows a well-defined process for IT governance.</li> <li>Thule Group continuously endeavors to keep the systems well protected and also invests in recovery plans, data storage functions, IT security expertise and employee training in information security with the aim of increasing internal know-how and awareness of the risks posed by increased threats and attacks on the company's IT infrastructure.</li> <li>Thule Group continuously strengthens its technical IT security.</li> <li>Continuous reviews and evaluations are conducted of the Group's systems and system providers as well as of procedures for data and information security.</li> </ul>
<b>PATENT</b>	<ul style="list-style-type: none"> <li>As the Juvenile &amp; Pet product category grows, this means increased exposure in a segment with well-established competitors as well as others that are new for Thule Group. This means increased risk of disputes over intellectual property such as patent rights.</li> </ul>			<ul style="list-style-type: none"> <li>Thule Group has a department with proven expertise and experience in handling intellectual property such as brands and patents.</li> <li>There are clearly developed routines and processes to evaluate intellectual property risks and leverage opportunities at early stages of and throughout the product development process.</li> </ul>
<b>TAXES</b>	<ul style="list-style-type: none"> <li>Operations are pursued in accordance with Thule Group's interpretation of applicable laws and tax regulations. If these interpretations should prove to be incorrect, they could have an adverse impact Thule Group's earnings.</li> </ul>			<ul style="list-style-type: none"> <li>Thule Group has a clear tax policy that sets out the company's fundamental approach to and management of considerations in conjunction with tax questions.</li> <li>Thule Group has resources in place to ensure continuous assessments in ample time prior to any changes. Requisite provisions to cover any disputes that may arise are made in consultation with experts.</li> </ul>
<b>DEFICIENCIES IN SUSTAINABILITY EFFORTS</b>	<ul style="list-style-type: none"> <li>The confidence of society and the market in Thule Group's sustainability efforts is a prerequisite for successful operations.</li> <li>Deficiencies in sustainability work can have a considerable negative impact on customer relationships in, for example, the automotive or sport and leisure industries.</li> <li>A precondition for an investor collective's investment in a company is often that the company meets their sustainability requirements.</li> </ul>		<a href="#">ESRS-2</a>	<ul style="list-style-type: none"> <li>General sustainability targets relating to the environment, quality and social responsibility are monitored on a quarterly basis.</li> <li>Thule Group pursues comprehensive quality and sustainability initiatives that impose requirements on both our own operations and those conducted by suppliers.</li> <li>Thule Group continuously trains employees and suppliers in the Group's Code of Conduct.</li> </ul>
<b>CORRUPTION AND BRIBERY</b>	<ul style="list-style-type: none"> <li>Corruption threatens sustainable economic and social development around the world, particularly in poor regions. Corruption may exist to various extents in some countries and in different sectors of society.</li> <li>Thule sells products in 138 countries, and purchases products and components from more than 750 suppliers. This means that we, like many other companies, run a risk of becoming involved in unethical business transactions, fraud and irregularities in areas encompassing sales and procurement processes.</li> </ul>		<a href="#">G-1</a>	<ul style="list-style-type: none"> <li>Thule Group applies zero tolerance to unethical business practices. The Group conducts obligatory courses on the Group's Code of Conduct for employees, suppliers and business partners. In addition, courses are held on the regulatory framework pertaining to anticorruption and other policies. Combined with the framework of internal control and monitoring, this provides the foundation for an ethical business approach and correct financial reporting.</li> <li>Thule Group applies global and local authorization manuals in to avoid conflicts of interest.</li> <li>Thule Group applies procurement processes that ensure sound business ethics.</li> <li>Thule Group provides suppliers with training on the Group's Code of Conduct, and conducts CSR audits, both in-house and in partnership with the company Intertek, to monitor and audit compliance with the Code of Conduct.</li> </ul>
<b>RESPONSIBLE MARKETING</b>	<ul style="list-style-type: none"> <li>Responsible and ethical marketing is required to avoid claims of greenwashing, and to ensure transparency and accountability for our operations, business activities, and to provide accurate information related to our products.</li> </ul>		<a href="#">S-4</a>	<ul style="list-style-type: none"> <li>We use a holistic approach to marketing, whereby sustainability, branding, and responsible communications are integrated to ensure maximum transparency, and provide the right information to our customers.</li> </ul>

## Employees and remuneration

### NUMBER OF EMPLOYEES

The average number of employees was 2,808 (2,559).

### REMUNERATION TO SENIOR EXECUTIVES

Guidelines for remuneration to senior executives were approved by the 2023 Annual General Meeting for the period until the 2027 Annual General Meeting. These guidelines as well as the expensed amounts are presented in Note 11.

### GUIDELINES FOR REMUNERATION TO SENIOR EXECUTIVES

The Board of Directors of Thule Group AB (publ) proposes that the general meeting resolves to adopt the following guidelines for executive remuneration.

The executives covered by the guidelines are the CEO and the other members of the Group Management. The basis for the remuneration to members of the Group Management shall be the sustainability of the company within a commercial financial development, organizational structure to provide for a professionalism that is adapted to the company's strategic objectives and also to provide the company with the adequate competence and resources at any given time. The remuneration to the Group Management shall comprise of fixed salary on market terms and variable remuneration, intended to stimulate the fulfillment of objectives of the company's commercial and sustainable development, pension benefits and competitive other benefits. The total remuneration shall be on market terms, be competitive and reflect the individual's performance and responsibilities.

For employments governed by rules other than Swedish, pension benefits and other benefits may be duly adjusted for compliance with mandatory such rules or established local practice, taking into account, to the extent possible, the overall purpose of these guidelines.

In accordance with a resolution by the annual general meeting 2023, a long-term share-based

incentive scheme is established in the company. Such scheme is excluded from these guidelines. The purpose of the share-based incentive scheme is, among other things, to stimulate a sustainable and favorable value development of Thule Group's share that will benefit the shareholders. The basis of the incentive scheme is the company's strategic plan and sustainable development and constitute an incentive to fulfill the growth objectives that the company stipulated in its strategic three year plan.

Fixed salary shall be on market terms. The variable remuneration may compromise of annual variable cash remuneration and long-term variable cash remuneration. Annual variable cash remuneration shall be measured during a calendar year and be conditional upon the fulfillment of predefined and measurable objectives in relation to EBIT results, sales development, other financial objectives, sustainability objectives and/or other personal objectives. The annual variable remuneration shall amount to a maximum of 100 per cent of the annual fixed salary for the CEO and 80 per cent for the other executives, with requirements to use 50 per cent of the compensation net of tax to invest in the Thule share with a minimum holding period of three years.

If and to the extent the general meeting does not resolve to implement long-term share-based incentive schemes, variable remuneration may also consist of a long-term variable cash remuneration that is implemented annually. To participate in the scheme for long-term variable remuneration, an own investment is required by the participant. Long-term variable remuneration must be measured over a period of at least three calendar years and be conditional upon the fulfillment of predefined and measurable objectives during the measurement period, and the payment is conditional on a predetermined fulfillment of objectives within sustainability. The long-term variable remuneration must, with regard to each measurement period, be amount to a maximum of 150 per cent of the fixed salary.

The terms and conditions for variable remuneration shall be designed so that the Board of Directors may choose, under exceptional economic circumstances, to limit or refrain from payment

of variable remuneration if such a measure is considered reasonable.

For members of the Group Management, pension benefits, including health insurance (Sw: sjukförsäkring), shall be premium defined. Variable cash remuneration shall not qualify for pension benefits. The pension premiums for premium defined pension shall amount to not more than 35 per cent of the annual fixed salary.

Other benefits may include, among other things, life insurance, medical insurance (Sw: sjukvårdsförsäkring), company car and fuel benefit. Such benefits may amount to a maximum of 15 per cent of the annual fixed salary.

Severance payments may be made when the employment is terminated by Thule Group. Members of the Group Management shall have a period of notice of not more than 12 months, in combination with severance pay corresponding to a maximum of 12 months fixed salary. No severance payment will be made when the employment is terminated by the employee.

In the preparation of the Board of Directors' proposal for these remuneration guidelines, remuneration and employment conditions for employees of the company have been taken into account, in that information on the employees' total income, the components of the remuneration and increase and growth rate over time has constituted part of the basis of decision in the Remuneration Committee and the Board of Directors in evaluating the reasonableness of the guidelines and the limitations following from these. The development of the gap between the remuneration to executives and remuneration to other employees will be disclosed in the remuneration report.

The Board of Directors has established a Remuneration Committee. The Committee's tasks include preparing the Board of Directors' decision to propose guidelines for executive remuneration. The Board of Directors shall prepare a proposal for new guidelines at least every four years and submit it to the AGM. The guidelines shall be in force until new guidelines are adopted by the general meeting. The Remuneration Committee shall also monitor and evaluate programs for variable remuneration

for the Group Management, the application of the guidelines for executive remuneration as well as the current remuneration structures and compensation levels in the company. The members of the Remuneration Committee are independent of the company and its management. The CEO and other members of the Group Management do not participate in the Board of Directors' processing of and resolutions regarding remuneration-related matters in so far as they are affected by such matters.

The Board of Directors may temporarily resolve to derogate from the guidelines, if in a specific case there is special cause for the derogation and a derogation is necessary to serve the company's long-term interests and sustainability, or to ensure the company's financial viability.

Details of the total remuneration to the Group Management, including previous commitments not yet due for payment, is included in the annual report. In addition, the company's remuneration report contains information on how the company has applied the guidelines for remuneration to the CEO and other senior executives.

### Description of significant changes to the guidelines and comments from shareholders

In relation to current guidelines, resolved by the 2023 AGM, the proposal for the 2025 AGM means that the company has increased the maximum annual variable remuneration to the CEO (by 25 percentage points) and the other executives (by 20 percentage points) and introduced a requirement to invest part of the variable remuneration in the Thule share. Furthermore, the detailed weighting of objectives for variable remuneration has been removed to increase flexibility in determining objectives for different senior executives, to ensure a relevant target structure.

### INCENTIVE PROGRAM

#### Share-based incentive program 2023/2026, 2024/2027 and 2025/2028

The warrants program 2024/2027 resolved on by the Annual General Meeting (AGM) for executive management and key employees of Thule Group was implemented in 2024. The program entails

the issue of a maximum of 2,778,000 warrants, distributed in equal parts in three series, to Thule Group's wholly owned subsidiary Thule AB, for further transfer to the participants.

During the year, a total of 326,009 warrants in series 2024/2027 were acquired by 28 participants. The warrants were transferred at a price of SEK 29.77 per warrant, which corresponded to the fair market price calculated by an external party at the time of transfer. The warrants can be exercised to subscribe for shares between June 15 and December 15, 2027 and the exercise price per share has been set at SEK 379.94, which corresponds to 120 percent of the volume-weighted average price according to Nasdaq Stockholm's official price list during the five trading days immediately preceding the transfer. The so-called roof price has been set at SEK 519.57, which corresponds to 164.1 percent of the same average share price. This means that if the market price of the company's share exceeds the roof price when the option is exercised, the exercise price shall be increased accordingly.

The third series, 2025/2028, will be implemented during 2025, but no later than June 15, 2025.

### ISSUE OF CONSIDERATION SHARES

Based on the authorization from the Annual General Meeting 2024, 2,105,065 new shares in Thule Group have been issued as part of the consideration in conjunction with the acquisition of Quad Lock. The shares represent 1.91 percent of the total number of shares and votes in Thule Group, on a fully diluted basis. The total number of shares in Thule Group has increased from 105,733,097 to 107,838,162. The share capital has increased SEK 23,526.94, from SEK 1,181,710 to SEK 1,205,237.

## Environment

### ENVIRONMENTAL IMPACT

Thule Group has a long history of environmental focus due to a commitment to develop high-quality products built to last for a long time, encourage employees with deep environmental engagement

and manage its own nine production facilities, not only to legal requirements, but to the higher Thule Group standards. The most important sustainability-related matters are integrated into the company's business and operational plans and reported in the annual sustainability report.

The Group is subject to a number of European Union, national, regional and local environmental and occupational health and safety laws, rules and regulations relating to the protection of the environment and natural resources including, among other things, the management of hazardous substances and waste, air emissions, the discharge of water, transportation, remediation of contamination and workplace health and safety.

Thule Group's operations require the Group to maintain certain environmental licenses for the production of its products including metal-based products with surface treatments and plastics. In addition, Thule Group's manufacturing sites have generally been certified according to the ISO 9001 quality management standards and IATF 16949 as well as the ISO 14001 environmental management system.

The plants outside Sweden adapt their operations, apply for the necessary licenses and report to authorities in accordance with local laws. The Group's Swedish plant, with the production facility in Hillerstorp, conducts operations that require an environmental license in accordance with Swedish environmental legislation.

Thule Sweden AB conducts class C operations under a license for class B operations and is classified as mechanical manufacturing in the form of metal working in a workshop area of less than 18,000 square meters and guarantees that its impact in the form of, for example, noise, dust and emissions to air and water, both in the immediate area and in general, from its manufacturing unit in Hillerstorp, Sweden is minimal. Systems are in place for classifying and sorting waste at source and for handling industrial waste. The unit is also certified pursuant to the environmental management standard EN-ISO 14001:2015, the quality management system EN-ISO 9001:2015, IATF 16949:2016 (quality management system for automotive industry

suppliers) and the occupational health and safety management system EN-ISO 45001:2018.

**SUSTAINABILITY REPORT**

The Group's Sustainability Report can be found on pages 33–71 and 125–133.

**Future development**

**FORECAST**

Thule Group does not present a financial forecast.

**The Thule share, shareholders and proposed appropriation of profits**

**NUMBER OF SHARES AND QUOTIENT VALUE**

The shares of Thule Group AB are listed on the Nasdaq Stockholm Large Cap list. The Group did not buy back or hold any treasury shares during the fiscal year. The number of shares approved, issued and fully paid as per December 31, 2024 was 107,838,162. The company has only one class of share. At general meetings of shareholders, each share carries one vote and each shareholder is entitled to vote for the full number of shares such a shareholder holds in the company.

All shares carry equal rights to the company's assets and profits. The quotient value (nominal value) of the share is SEK 0.01118 per share.

**LARGEST SHAREHOLDERS**

As of December 31, 2024, Thule Group AB had 26,443 known shareholders. On this date, the largest shareholders were AMF Försäkringar & Fonder (10.8 percent of the capital and votes), Swedbank Robur Fonder (7.9 percent of the capital and votes), Alecta (4.5 percent of the capital and votes) and Handelsbanken Fonder (4.1 percent of the capital and votes).

**ARTICLES OF ASSOCIATION**

The Articles of Association contain no separate provisions pertaining to the appointment and dismissal of Board members, nor to amendment of the Articles of Association.

**PROPOSED APPROPRIATION OF PROFITS Parent Company**

Proposed appropriation of the company's earnings.

At the disposal of the Annual General Meeting:

Share premium reserve, SEK	1,493,993,136
Net income, SEK	578,969,227
	<b>2,072,962,363</b>

The Board proposes that the profit brought forward be appropriated as follows:

Dividend to shareholders, SEK 8.30 x 107,838,162	895,056,745
To be carried forward, SEK	1,177,905,618
	<b>2,072,962,363</b>

# Corporate Governance Report

**Thule Group is a Swedish public limited liability company listed on the Nasdaq Stockholm Large Cap list. Thule Group's corporate governance is mainly regulated by the Swedish Companies Act and other Swedish laws, Nasdaq Stockholm's Rule Book for Issuers and the Swedish Corporate Governance Code, "the Code" (available at [corporategovernanceboard.se](http://corporategovernanceboard.se)). The Code is to be applied to all Swedish companies whose shares are traded on a regulated market-place in Sweden.**

Thule Group has applied the Code since November 26, 2014, when Thule Group's share started to be traded on Nasdaq Stockholm. The 2024 Corporate Governance Report describes Thule Group's corporate governance, management and administration as well as the internal control and risk management.

**THULE GROUP'S CORPORATE GOVERNANCE STRUCTURE**

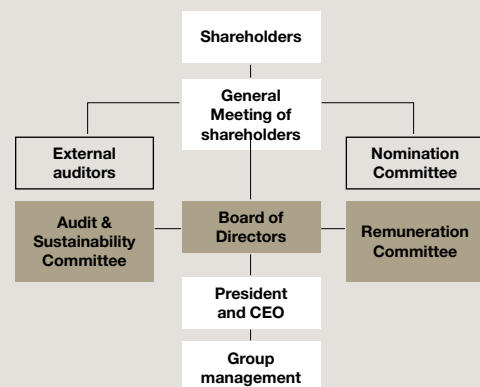

## REGULATORY COMPLIANCE

### External governance systems

The external governance systems that comprise the framework for corporate governance at the Thule Group primarily comprise the Swedish Companies Act, the Swedish Annual Accounts Act, Nasdaq Stockholm's Rule Book for Issuers, the Swedish Corporate Governance Code and other applicable rules and relevant legislation.

### Internal governance systems

The Articles of Association adopted by the Annual General Meeting (AGM) and the documents on the rules of procedure for the Board of Thule Group, instructions for the CEO and instructions for the Remuneration and Audit & Sustainability Committees, as adopted by the Board of Directors, are the most important internal governance documents. In addition, the Group has a number of policies and instructions containing rules and principles for the Group's operations and employees.

### Deviations from the Code

Companies are not obliged to at all times apply every rule in the Code, but are allowed the freedom to choose alternative solutions which they feel are better in their particular circumstances, provided they report every deviation, describe the alternative solution and explain the reasons for the deviation in its annual corporate governance report (the

"comply or explain" principle). Thule Group did not deviate from the rules of the Code in 2024 and therefore has no such deviations to report.

### GENERAL MEETING OF SHAREHOLDERS

Pursuant to the Swedish Companies Act (2005:551), the General Meeting is the company's highest decision-making body and the body where shareholders exercise their voting rights. Shareholders who are recorded in the share register on the record date and have notified the company of their intention to participate in the General Meeting not later than the date and time indicated in the notice are entitled to attend the Meeting in person or by proxy. Resolutions are made at the General Meeting normally by a simple majority. However, in certain matters, the Swedish Companies Act stipulates that a certain level of attendance is required to form a quorum or a qualified majority of votes.

Annual General Meetings must be held within six months from the end of each fiscal year. Thule Group's Annual General Meeting is usually held in April. The Annual General Meeting resolves on such issues as the Articles of Association and is tasked with appointing Board members and the Chairman of the Board, electing auditors and resolving to adopt the income statement, balance sheet and the appropriation of the company's profits, and the discharge from liability of the Board and the CEO vis-à-vis the company. In addition, where necessary,

the Annual General Meeting also resolves to adopt principles for the appointment and work of the Nomination Committee, and on principles for the terms of remuneration and employment for the CEO and other executive management.

An Extraordinary General Meeting can be held if specifically required. At the Annual General Meeting, shareholders have the opportunity to ask questions about the company and its results for the year just ended. In addition to annual general meetings (AGMs), extraordinary general meetings (EGMs) can be called. In accordance with the Articles of Association, notice of a general meeting is published in Post- och Inrikes Tidningar and on the company's website, [www.thulegroup.com](http://www.thulegroup.com). In conjunction with notice being given, an announcement is made of the notification in Dagens Industri. The Articles of Association contain no separate provisions pertaining to the appointment and dismissal of Board members, nor to amendment of the Articles of Association. For the complete Articles of Association, refer to the website [www.thulegroup.com](http://www.thulegroup.com).

## SHAREHOLDERS

Thule Group's share has been listed on Nasdaq Stockholm since November 26, 2014 and moved to the Large Cap list on January 1, 2017. At year end, the share capital amounted to SEK 1,205,237.17, divided between 107,838,162 shares. All of the

shares are of the same class and all of the shares in the company carry equal rights in all respects. As of December 31, 2024, Thule Group AB had 26,443 known shareholders. On this date, the largest shareholders were AMF Försäkringar & Fonder (10.8 percent of the capital and votes), Swedbank Robur Fonder (7.9 percent of the capital and votes), Alecta (4.5 percent of the capital and votes) and Handelsbanken Fonder (4.1 percent of the capital and votes). Further information about the share and shareholders is available at [www.thulegroup.com](http://www.thulegroup.com).

### RESOLUTIONS AT THE 2024 ANNUAL GENERAL MEETING

The 2024 AGM was held on April 26, 2024. The complete minutes of and information about the 2024 AGM are available at [www.thulegroup.com](http://www.thulegroup.com). The AGM resolved to adopt the submitted income statement and balance sheet and the consolidated income statement and consolidated balance sheet. In accordance with the Board's proposal, the AGM resolved to distribute a dividend of SEK 9.50 for the 2023 fiscal year. The dividend was distributed in two installments for a better adaptation to the Group's cash flow profile.

The AGM also resolved that the company's profit, together with earnings for 2023, were to be carried forward. The Meeting discharged the Board members and the CEO from liability and resolved on fees to Board members.

### 2025 ANNUAL GENERAL MEETING

The 2025 Annual General Meeting will be held on April 29 in Malmö. For more information, refer to [www.thulegroup.com](http://www.thulegroup.com).

### NOMINATION COMMITTEE

The Nomination Committee is, in accordance with the principles decided by the AGM in April 2019, to be composed of five members comprising representatives from each of the four largest shareholders in terms of the number of votes as of August 31 every year, and the Chairman of the Board.

The Nomination Committee member representing the largest shareholder in terms of votes is to be appointed as Chairman unless the Committee

unanimously appoints another. If more than three months prior to the Annual General Meeting, one or more of the shareholders who have appointed members to the Nomination Committee should cease to belong to the four largest shareholders in terms of votes, the members appointed by these shareholders are to vacate their membership and the shareholder/shareholders who has/have instead become among the four largest shareholders in terms of votes is/are to be entitled to appoint his/their representatives. If a member leaves the Nomination Committee before its work is completed and the Committee finds it desirable to appoint a replacement, the new member should be sourced from the same shareholder or, if this shareholder is no longer one of the largest shareholders in terms of votes, from the next shareholder in line. Changes in the composition of the Nomination Committee must be announced immediately.

The Nomination Committee's duties are to present proposals to the AGM regarding the

Chairman of the Board and other Board members together with an explanatory statement for the proposal, to propose fees and other remuneration for Board assignments for each of the Board members, including any remuneration for Committee work, to present proposals on auditors and their fees, to present a proposal for the Chairman of the AGM and, where appropriate, to propose changes to the appointment of the Nomination Committee. In addition, the Nomination Committee is to assess the independence of the Board members in relation to the company and the largest shareholders. The composition of the Nomination Committee for the AGM is normally announced on the company's website six months before the Meeting. No remuneration is paid to members of the Nomination Committee.

The company is to pay any necessary expenses that the Nomination Committee may incur in its work. The term of office for the Committee ends when the composition of the following Nomination Committee has been announced.

### NOMINATION COMMITTEE PRIOR TO THE 2025 ANNUAL GENERAL MEETING

The composition of the Nomination Committee was published in a press release and on [www.thulegroup.com](http://www.thulegroup.com) on October 14, 2024. The Nomination Committee prior to the 2025 Annual General Meeting comprises Anders Oscarsson (AMF Försäkring & Fonder), Magnus Sjökvist (Swedbank Robur Fonder), Helen Fasth Gillstedt (Handelsbanken Fonder), Carina Silberg (Alecta) and Hans Eckerström (Chairman of the Board of Thule Group AB).

After the 2024 Annual General Meeting and until the date on which this Annual Report was presented, the Nomination Committee held 5 meetings. As a basis for its proposals to the 2025 Annual General Meeting, the Nomination Committee assessed whether the current Board was appropriately composed and meets the requirements imposed on the Board considering the company's operations, financial position and other circumstances.

The Nomination Committee interviewed the company's Board members and discussed the main requirements that should be imposed on Board members, including the independence of members given the number of Board assignments that they have in other companies.

### BOARD OF DIRECTORS Composition in 2024

The Board's duty is to manage the company's affairs on behalf of the shareholders. Under the Articles of Association, the Board of Thule Group is to comprise no fewer than three and not more than ten members appointed by the AGM for the period until the end of the next AGM. Six Board members were re-elected at the Annual General Meeting on April 26, 2024: Hans Eckerström, Anders Jensen, Sarah McPhee, Johan Westman and Helene Willberg. Sandra Finér and Paul Gustavsson were newly elected. Heléne Mellquist declined re-election.

#### NOMINATION COMMITTEE

Name	Appointed by	Percentage of votes Sep 30, 2024, %
Anders Oscarsson	AMF Försäkring & Fonder	11.7
Magnus Sjökvist	Swedbank Robur Fonder	8.5
Helen Fasth Gillstedt	Handelsbanken Fonder	5.5
Carina Silberg	Alecta Tjänstepension	4.8
Hans Eckerström	Chairman of the Board of Thule Group	

#### BOARD COMPOSITION

Name	Year elected	Total fee, SEK (annual) <sup>1</sup>	Independent	Attendance		
				Board meetings	Audit & Sustainability Committee	Remuneration Committee
<b>Chairman</b>						
Hans Eckerström	2009	1,540,000	Yes	15/15		5/5
<b>Board members</b>						
Heléne Mellquist <sup>2</sup>	2016	-	Yes	4/4		1/1
Helene Willberg	2019	730,000	Yes	15/15	8/8	
Johan Westman	2022	455,000	Yes	15/15		
Sarah McPhee	2022	565,000	Yes	15/15	8/8	
Anders Jensen	2023	455,000	Yes	15/15		
Sandra Finér <sup>3</sup>	2024	455,000	Yes	11/11		
Paul Gustavsson <sup>3</sup>	2024	505,000	Yes	11/11		4/4

<sup>1</sup> Fee resolved at the 2024 Annual General Meeting.

<sup>2</sup> Heléne Mellquist declined re-election at the 2024 Annual General Meeting.

<sup>3</sup> Sandra Finér and Paul Gustavsson were elected as Board members at the 2024 Annual General Meeting.

Moreover, Hans Eckerström was elected Chairman of the Board. No member of Group management is a Board member. Both the CEO and the CFO of Thule Group participate at Board meetings. Other officers of the company participate at Board meetings when presenting separate issues.

In its reasoned statement ahead of the 2024 AGM, the Nomination Committee stated that it had applied rule 4.1 of the Swedish Corporate Governance Code on diversity policy. The objective of the policy is to ensure that the Board of Directors will, with consideration for the company's business, phase of development and other relevant circumstances, have an appropriate composition of Board members that collectively display diversity and breadth in respect of skills, experience and background, and an equal gender distribution. The 2024 AGM resolved to appoint the Board members in accordance with the Nomination Committee's proposal, entailing the election of seven members, three of whom were women and four men. Annual fees to the Board's members are decided by the AGM.

For 2024, fees amounted to SEK 1,445,000 to the Chairman of the Board and SEK 455,000 to each of the other Board members. The Chairman of the Audit & Sustainability Committee is to receive remuneration of SEK 275,000 for Committee work, while SEK 110,000 is to be paid to each of the other members. The Chairman of the Remuneration Committee is to receive remuneration of SEK 95,000 for Committee work, while SEK 50,000 is to be paid to each of the other members.

#### Independence of the Board

In accordance with the Code, a majority of the members of the Board elected by the General Meeting are to be independent in relation to the company and its management. The independence of the Board members is presented in the table Board composition.

Each member's assessment of his or her independence in relation to the company, its management and major shareholders is presented in the Facts about the Board and Group management section.

The composition of the Board meets the Code's requirements for independence.

#### Responsibilities of the Chairman

The Chairman of the Board leads the Board's work and ensures that activities are conducted efficiently. The Chairman ensures that the Swedish Companies Act and other applicable laws and regulations are adhered to and that the Board receives the necessary training and improves its knowledge of the company. The Chairman monitors the operations in close dialog with the CEO, conveys opinions from shareholders to other Board members and serves as a spokesman for the Board.

The Chairman is also responsible for providing the other members of the Board with information and decision data and for implementing Board decisions.

In addition, the Chairman is responsible for ensuring that the work of the Board is evaluated every year and reported to the Nomination Committee.

#### Board responsibilities and work

The duties of the Board of Directors are primarily set out in the Swedish Companies Act and the Code. In addition, the work of the Board is guided by rules of procedure that the Board adopts every year. The rules of procedure regulate the allocation of work and responsibility between the Board, Chairman of the Board and CEO, as well as stipulate procedures for financial reporting by the CEO.

The Board also adopts instructions for the Board's Committees. The Board is tasked with establishing strategies, business plans and budgets as well as submitting interim financial statements, annual accounts, and adopting policies and guidelines. The Board is also charged with following the financial developments, ensuring the quality of financial reporting and control functions and evaluating the company's operations based on the established goals and guidelines adopted by the Board. Finally, the Board also takes decisions regarding major investments and organizational and operational changes in the company.

Working closely with the CEO, the Chairman of the Board is tasked with monitoring the company's performance and acting as Chairman at Board meetings. The current rules of procedure state

that the Board is to meet at least six times a year in addition to the statutory meeting following election. The Board held 15 meetings during the year, of which four were held per capsulam. All Board meetings follow a predetermined agenda. Attendance at Board meetings is presented in the table on the composition of the Board.

In 2024, the Board mainly addressed matters regarding the operations, budget, acquisitions (including the acquisition of Quad Lock) strategic direction, sustainability and CSR matters as well as company law issues.

#### BOARD COMMITTEES

The Board has two committees, the Remuneration Committee and the Audit & Sustainability Committee. The committees report on the issues addressed to the Board in connection with Board meetings. The work of the respective committees is carried out pursuant to written instructions and rules of procedure from the Board. Minutes of the committees' meetings are available to all Board members.

#### Remuneration Committee

The Remuneration Committee is tasked with preparing issues regarding remuneration and other terms of employment for the CEO and the company's executive management. The work involves the preparation of proposals for guidelines for items, such as: the allocation between fixed and variable remuneration, the relationship between performance and compensation, the main terms of bonus and incentive programs, conditions for other benefits, pensions, termination and severance pay, and the preparation of proposals for individual remuneration packages for the CEO and executive management.

Furthermore, the Remuneration Committee also monitors and evaluates the outcome of variable remuneration, and how the company complies with the remuneration guidelines adopted by the general meeting of shareholders.

Until the Annual General Meeting, the Remuneration Committee consisted of Hans Eckerström (Chairman) and Heléne Mellquist. From the Annual General Meeting, the Remuneration Committee

<b>AUDIT FEES</b>				
<b>SEKm</b>	<b>Group</b>		<b>Parent Company</b>	
	<b>2024</b>	<b>2023</b>	<b>2024</b>	<b>2023</b>
Audit PwC	5.0	3.9	1.9	1.2
Audit-related advisory services beyond the scope of the audit assignment PwC	0.1	—	0.1	—
Tax consultancy PwC	—	0.6	—	0.6
Other services PwC	0.8	0.4	0.8	0.4
<b>Total</b>	<b>5.9</b>	<b>5.0</b>	<b>2.8</b>	<b>2.2</b>

consisted of Hans Eckerström (Chairman) and Paul Gustavsson. The Remuneration Committee held five meetings in 2024, of which three were held per capsulam. The members' attendance at meetings of the Remuneration Committee is presented in the table Board composition.

#### Audit & Sustainability Committee

The main task of the Audit & Sustainability Committee is to ensure that the Board meets the supervision requirements relating to accounting and financial reporting, internal control regarding financial reporting, auditing, financial risk management and prepares accounting and auditing matters. The Audit & Sustainability Committee is also tasked with monitoring the company's sustainability reporting and the company's preparations for the implementation of CSRD in 2025. In addition, the Committee monitors the impartiality and independence of the auditor and evaluates the audit work. The Audit & Sustainability Committee also assists the company's Nomination Committee when preparing proposals for auditors and recommendations for auditor's fees.

The Audit & Sustainability Committee in Thule Group comprises two members, Helene Willberg (Chairman) and Sarah McPhee. Throughout 2024, Helene Willberg was Chair of the Audit & Sustainability Committee with Sarah McPhee as

a committee member. The Audit & Sustainability Committee held eight meetings in 2024. The members' attendance at meetings of the Audit & Sustainability Committee is presented in the table Board composition.

The Audit & Sustainability Committee meets all the requirements vis-à-vis auditing and accounting competence as stipulated in the Swedish Companies Act.

#### AUDITORS

The auditor is elected at the Annual General Meeting every year. The auditors review the company's and subsidiaries' financial reports and accounts as well as the administration of the Board and the CEO. The auditor participates at the Board meeting that addresses the year-end accounts. At this meeting, the auditor presents the financial information and discusses the audit with the Board members without the CEO and executive management attending. The auditor maintains continuous contact with the company and its management.

Thule Group's auditors are to review the Annual Report and consolidated financial statements for Thule Group AB and the administration of the Board and the CEO. The auditors follow an audit plan that is discussed with the Audit & Sustainability Committee.

Reports were presented to the Audit & Sustainability Committee during the course of the audit and finally to the Board as a whole when the year-end report was adopted. The auditor is also to attend the Annual General Meeting and describe the audit activities and observations made in an auditor's report. The 2017 Annual General Meeting elected PricewaterhouseCoopers AB as Auditor in Charge. In conjunction with the 2024 Annual General Meeting, Öhrlings PricewaterhouseCoopers AB was re-elected for a term of one year with Sofia Götmar-Blomstedt as Auditor in Charge. The appointed auditor is responsible for auditing all of the important subsidiaries in the Group (with the exception of the part of the Group – the recently acquired Quad Lock).

#### **CEO AND OTHER EXECUTIVE MANAGEMENT**

The CEO is subordinate to the Board of Directors and is responsible for the day-to-day management and operations of the company. The division of work between the Board of Directors and the CEO is set out in the rules of procedure for the Board of Directors and instructions for the CEO. The CEO is also responsible for the preparation of reports and compiling information from management for Board meetings and for presenting such material at Board meetings.

According to the instructions for financial reporting and sustainability reporting, the CEO is responsible for the financial reporting in Thule Group and consequently must ensure that the Board receives adequate information for the Board to be able to evaluate the company's and the Group's financial position and sustainability work. The CEO keeps the Board continuously informed of developments in Thule Group's operations, the development of sales, Thule Group's results and financial position, important sustainability topics, liquidity and credit status, important business events and all other events, circumstances or conditions that can be assumed to be of significance to the company's shareholders.

Information about remuneration, share-based incentive programs and terms of employment for the

CEO and other executive management is available at [www.thulegroup.com](http://www.thulegroup.com).

#### **INTERNAL CONTROL AND RISK MANAGEMENT**

The Board's responsibility for the internal control is governed by the Swedish Companies Act, the Swedish Annual Accounts Act (1995:1554), and the Code.

Information regarding the most important aspects of the company's system for internal control and risk management in connection with financial reporting must each year be included in the company's Corporate Governance Report.

The procedures for internal control, risk assessment, control activities, and monitoring with respect to the financial reporting have been designed to ensure reliable overall financial reporting and external financial reporting in accordance with IFRS, applicable laws and regulations as well as other requirements, which apply to companies listed on Nasdaq Stockholm. This work involves the Board, Group management and other personnel.

#### **Control environment**

The Board has adopted instructions and governance documents aimed at regulating the roles and allocation of responsibility between the CEO and the Board. The way in which the Board monitors and ensures quality in the internal control is documented in the Board's rules of procedure and Thule Group's finance policy.

The control environment also includes the Board evaluating the performance and results of the operations through monthly and quarterly report packages. The reporting contains outcomes, budget comparisons, forecasts, operational targets, strategic plans, assessment and evaluation of financial risks, and analysis of important financial, sustainability- and operational key figures. The responsibility for the presentation of the report package to the Board and the responsibility for maintaining an effective control environment, and the day-to-day risk assessment and internal control over the financial reporting are delegated to the CEO. However, the Board is ultimately responsible.

Managers at various levels in Thule Group's business areas are, in turn, responsible for ensuring compliance with established guidelines within their business area.

#### **Risk assessment and control activities**

The company conducts continuous risk assessment to identify risks in all areas of operation. These risks, which include the risk of both loss of assets as well as irregularities and fraud, are assessed regularly by the Board. The structure of control activities is of particular importance in the company's work of preventing and discovering deficiencies. The assessment and control of risks also cover the operational management of each reporting unit, where meetings are held at least six times a year in connection with business review meetings. Thule Group's CEO and CFO, as well as local and regional management, participate at these meetings.

#### **Information and communication**

The company's governance documents for financial reporting primarily comprise guidelines, policies and manuals that are continuously updated and communicated to the appropriate employees via relevant information channels. A communication policy is in place for external information that provides guidelines on how such information is to be provided. The aim of the policy is to ensure that the company complies with the requirements for disseminating correct and complete information to the market.

#### **Monitoring, assessment and reporting**

The Board regularly assesses the information provided by Group management. Between Board meetings, the Board regularly receives updated information regarding Thule Group's performance. Thule Group's financial position, operations, development and capital expenditures are discussed at each Board meeting. The Board is also responsible for monitoring the internal control. This work includes ensuring that measures are taken to address any deficiencies, as well as follow-up of proposals for measures to which attention has been drawn in connection with the external audit.

Each year, the company carries out a self-assessment of the risk management and internal control work. This process includes a review of the manner in which established routines and guidelines are applied. The Board receives information regarding important conclusions drawn from this annual assessment process, and regarding any measures relating to the company's internal control environment.

#### **Internal audit**

Under paragraph 7.3 of the Code, the Board is to annually evaluate the need for a separate audit function, which is to ensure that financial reports are produced in accordance with legislation, applicable accounting standards and other applicable requirements for listed companies. Considering the internal control activities that have been performed, the Board does not deem there to be any need to establish a separate internal audit function.

## Board of Directors

### HANS ECKERSTRÖM

Chairman  
Chair of the remuneration committee.

Born 1972.  
Member of the Board since 2007.  
Member of the Board of a former parent company of Thule Group 2007-2009.  
Chairman of the Board since 2022.  
**Education:** Master of Science Mechanical Engineering, Chalmers University of Technology. Master of Science Business Administration, University of Gothenburg.  
**Professional experience:** Previously, Management Consultant at Arthur D. Little. Partner, NC Advisory AB and advisor to the Nordic Capital Funds, CIO for Aligro Planet Acquisition Company.  
**Other current board appointments:** Chair of Profoto Invest AB and Profoto Holding AB. Board member of Swedbank AB (publ).  
**Previous board appointments (relevant selection):** Chair of Henry Lloyd Group AB, Nobia AB (publ), Brink International AB and Britax Childcare Limited.  
Board member of Nordstjärnan AB, Nefab AB (publ), Cloetta AB (publ) and Aditro AB.  
**Holdings in Thule Group:** As of 1st March 2025: Shares 35,000 (legal person).



**Independence:** All members are independent in relation to the company's owners.

### ANDERS JENSEN

Member of the Board

Born 1977.  
Member of the Board since 2023.  
**Education:** Bachelor in Marketing from IHM Business School, Stockholm, Sweden.  
**Professional experience:** CEO and President of Cary Group Holding AB. Previously founder of Samglas AB, where he also was CEO and board member. Appointed CEO of the company when Samglas was later acquired by Ryds Bilglas AB.  
**Other current board appointments:** Board member of RS Sport.  
**Relevant sustainability experience:** CEO of Cary Group with extensive sustainability work, including SBTi-verified sustainability goals.  
**Holdings in Thule Group:** As of 1st March 2025: Shares 17,862 (own).



### SANDRA FINÉR

Member of the Board

Born 1979.  
Member of the Board since 2024.  
**Education:** Master of Science degree in chemical engineering from Chalmers University of Technology, Gothenburg, Sweden and educated in organizational psychology and business administration.  
**Professional experience:** Senior Vice President Service Market Logistics Volvo Group. Previously Vice President Operations and Plant Manager at Volvo Trucks' factory in Tuve, Gothenburg, Sweden. CEO of start-up company Limes Audio and Head of Product Development at BabyBjörn AB.  
**Other current board appointments:** Member of the Board of Umeå University and Umeå University Holding AB, Sweden.  
**Holdings in Thule Group:** As of 1st March 2025: Shares 250 (own).

### HELENE WILLBERG

Member of the Board  
Chair of the audit & sustainability committee

Born 1967.  
Member of the Board since 2019.  
**Education:** Master of Science Stockholm School of Economics, Sweden.  
**Professional experience:** Previously, Country Head Alvarez & Marsal Sweden AB, and several leading roles at KPMG, including as CEO of KPMG Sweden and as Head of KPMG's Financial Advisory Services. Former authorized public accountant.  
**Other current board appointments:** Chair of Accru Partners Group AB. Board member of Enzymatica AB (publ).



### SARAH MCPHEE

Member of the Board  
Member of audit & sustainability committee

Born 1954.  
Member of the Board since 2022.  
**Education:** Bachelor of Science in Economics from the Stockholm School of Economics, Sweden, a Master of Arts from Stanford University, USA and a Bachelor of Arts from Wesleyan University, USA.  
**Professional experience:** Previously CEO at SPP and Executive Vice President of Storebrand ASA. Held several leading roles in AMF Pension, The Fourth Swedish National Pension Fund, Svenska Handelsbanken and GE Capital.  
**Other current board appointments:** Chair of the Board of Houdini Sportswear AB and board member of Bure Equity AB and Karolinska Institutet.



**Previous board appointments (relevant selection):** Chair of the board of The Fourth Swedish National Pension Fund and the Center for Business and Economic Studies (SNS). Board member of Klarna AB, Grover GmbH, SAXO Bank and Axel Johnson Inc.  
**Relevant sustainability experience:** Sweden's third most environmentally powerful CEO 2015 according to Miljöaktuellt. When Chair of The Fourth Swedish National Pension Fund, awarded most climate friendly pension fund in the world (IFC). Built up first sustainable index funds in Sweden at SPP.  
**Holdings in Thule Group:** As of 1st March 2025: Shares 1,000 (own) and 2,652 (legal person).

### JOHAN WESTMAN

Member of the Board

Born 1973.  
Member of the Board since 2022.  
**Education:** Master of Science in Industrial Engineering and Management from Chalmers University of Technology, Gothenburg, Sweden.  
**Professional experience:** President and CEO AAK (publ). Previously been Senior Vice President Europe and Managing Director of the BlankLight division at Shiloh Industries, Inc. CEO and President within FinnvedenBulten Group (publ). Additionally, several years of experience as a management consultant at Arthur D. Little.  
**Other current board appointments:** Chair of the Board of Absolent Air Care Group AB (publ).  
**Relevant sustainability experience:** Participation in sustainability work including the World Economic Forum in his roles at AAK, Shiloh and FinnvedenBulten.  
**Holdings in Thule Group:** As of 1st March 2025: Shares 3,332 (own)



### PAUL GUSTAVSSON

Member of the board  
Member of the remuneration committee

Born 1966.  
Member of the Board since 2024.  
**Education:** Master of Science degree in Industrial Engineering and Management from Chalmers University of Technology, Gothenburg, Sweden.  
**Professional experience:** Group CEO of Vexve Group, Finland. Previously group CEO of Nordkalk Group and Britax Group Ltd and before that held several positions within Volvo Cars, including as Senior Vice President and member of the corporate management.  
**Other current board appointments:** Board member Consenz International AB.

**Previous board appointments (relevant selection):** Chairman of the Board of CPAC System AB. Board Member Svermin, Svenskt Näringsliv Mining Industry. Board Member and Chairman of several Joint Ventures in the engineering industry.  
**Relevant sustainability experience:** Led Volvo Cars' electrification initiative and several sustainability initiatives in the mining and minerals industry. CEO of several companies with extensive sustainability reporting.  
**Holdings in Thule Group:** As of 1st March 2025: Shares 1,120 (own)

## Group Management

### MATTIAS ANKARBERG

CEO and President

Born 1976.  
**Employed since:** 2023  
 Member of the board 2018–2023.  
**Education:** Master of Science in Economics and Business Administration, Stockholm School of Economics, Sweden.  
**Professional experience:** CEO of Byggmax Group, leading positions at the H&M Group and Consultant at McKinsey & Company in Sweden and USA.  
**Current board appointments:** Chair of Sigrid Therapeutics AB.  
**Holdings in Thule Group:** As of 1st March 2025: Shares 10,000 (own), warrants Series 2023/2026: 110,000, warrants Series 2024/2027: 100,772.



### TOBY LAWTON

Vice President Category Management

Born 1974.  
**Employed since:** 2024.  
**Education:** Master of Arts in Physics from Oxford University, UK.  
 Member of the Chartered Institute of Management Accountants and Association of Corporate Treasurers.  
**Professional experience:** CFO Svenska Cellulose SCA (publ), CFO Renewcell AB (publ), CFO Vinda International Holdings Limited, CFO Asia Pacific and VP M&A in the SCA Group.  
**Holdings in Thule Group:** As of 1st March 2025: Shares: 750 (own), warrants series 2023/2026: 40,000, warrants series 2024/2027: 36,949.

### ADEN JOHNSON

Vice President Category Management

Born 1985.  
**Employed since:** 2021.  
**Education:** Bachelor of Political Science and Communication Studies, Vanderbilt University, Nashville, TN, USA.  
**Professional experience:** VP of Merchandising North America at Victorinox Swiss Army Inc., VP of Merchandising at Vineyard Vines, LLC., Director of Global Merchandising at Ralph Lauren Corporation.  
**Holdings in Thule Group:** As of 1st March 2025: Warrants Series 2024/2027: 7,000.



### ANDREAS HÄGGLUND

Senior Vice President Supply Chain

Born 1981.  
**Employed since:** 2019.  
**Education:** Master of Science in Industrial Engineering and Management, Linköping University, Sweden.  
**Professional experience:** Various leading positions within logistics and Supply Chain at Thule Group. Logistics Manager within Mekonomen Group and RNB Retail and Brands.  
**Holdings in Thule Group:** As of 1st March 2025: Warrants series 2023/2026: 4,000, warrants series 2024/2027: 4,000.

### CATHARINA PAULCÉN

Senior Vice President Corporate Communications & Investor Relations

Born 1973.  
**Employed since:** 2024  
**Education:** Bachelor in Business Administration at Lund University, Sweden.  
**Professional experience:** Head of Corporate Communications at Lindab, EVP Marketing & Commercial support at Haldex, SVP Marketing & Communications at Enea, Director of Marketing at IBM and EVP Marketing & Communications at Telelogic.  
**Current board appointments:** Chairman of Friluftsvävar Nordic AB, Board member of NorDisk Clean Solutions AB.  
**Holdings in Thule Group:** As of 1st March 2025: Shares: 1,000 (own), warrants Series 2024/2027: 20,000.



### DANIEL LARSSON

Senior Vice President Commercial

Born 1975.  
**Employed since:** 2019.  
**Professional experience:** Various management positions at VF Corporation, including Sales Director for Lee and Wrangler, Sales Director and Go To Market Director for The North Face.  
**Holdings in Thule Group:** As of 1st March 2025: Shares: 14,785 (own), warrants Series 2023/2026: 29,940, warrants Series 2024/2027: 26,872.



### FILIP VAN DER LINDEN

Vice President, Business unit Recreational Vehicle

Born 1963.  
**Employed since:** 2010.  
**Education:** Master in Applied Economic Sciences with a specialization in marketing, University of Antwerp, Belgium.  
**Professional experience:** VP Category leader at Ceramics EMEA, VP Marketing at Ideal Standard International, VP Sales, Central Europe. Other various management positions internationally at Whirlpool Europe & Whirlpool Corporation and product management at Philips Belux.  
**Holdings in Thule Group:** As of 1st March 2025: Shares: 53,869 (own), warrants Series 2023/2026: 10,000, warrants Series 2024/2027: 7,000.

### HELENA DINO

Senior Vice President Human Resources

Born 1967.  
**Employed since:** 2024.  
**Education:** Bachelor in Human Resources at the University of Gothenburg, Sweden.  
**Professional experience:** Transformation Lead & HR Manager at Mediq Sweden & Norway, Interim CHRO for Kry Livi, HR Director for Castellum, Senior HR Director at Volvo Cars and HR Manager for Volvo Ocean Race.  
**Holdings in Thule Group:** As of 1st March 2025: Warrants Series 2024/2027: 9,000.



### HILARY HARTLEY

Senior Vice President Global Business Development

Born 1967.  
**Employed since:** 2021.  
**Education:** Bachelor of Business Administration, Marketing, University of Maine, USA.  
**Professional experience:** President North America at Victorinox Swiss Army Inc., Vice President North America, at Oakley / Luxottica, Managing Director at Oakley, Canada. Sales, Product Development and Marketing roles at Rossignol Ski Company.  
**Current board appointments:** Vice Chairman Outdoor Foundation Board.  
**Holdings in Thule Group:** –

### KARL-JOHAN MAGNUSSON

Senior Vice President Product Development

Born 1972.  
**Employed since:** 1999.  
**Education:** Bachelor of Science in Mechanical engineering from Halmstad University, Sweden.  
**Professional experience:** Various leading positions within product development and product management at Thule Group. Engineering & supply at Turnils AB.  
**Current board appointments:** Board member Stiftelsen Forum Finnveden.  
**Holdings in Thule Group:** As of 1st March 2025: Shares: 1,365 (own), warrants Series 2023/2026: 26,500, warrants Series 2024/2027: 10,000.



### TINA LISELIUS

Vice President Global Brand

Born 1975.  
**Employed since:** 2012.  
**Education:** University studies in law, language and history at Lund University, Sweden, Sorbonne University in Paris and Nice University, both in France.  
**Professional experience:** Media and IMAP manager at Saab Automotive in Trollhättan and Pan European Sales Manager at Eurosport Television in Paris and Stockholm.  
**Holdings in Thule Group:** As of 1st March 2025: Warrants: Series 2023/2026: 29,940, warrants: Series 2024/2027: 26,872.



# Financial statements

Consolidated income statement	90
Consolidated statement of comprehensive income	90
Consolidated balance sheet	91
Consolidated statement of changes in equity	92
Consolidated statement of cash flow	92
Parent Company income statement	93
Parent Company statement of comprehensive income	93
Parent Company balance sheet	93
Parent Company statement of changes in equity	94
Parent Company cash flow statement	94

## Consolidated income statement

January 1– December 31, SEKm	Note	2024	2023
Net sales	6, 7	9,541	9,132
Cost of goods sold		-5,467	-5,395
<b>Gross income</b>		4,074	3,737
Selling expenses		-2,005	-1,820
Administrative expenses		-547	-412
<b>Operating income</b>	9, 11, 12, 13	<b>1,522</b>	<b>1,505</b>
Financial revenue	14	97	79
Financial expenses	14	-172	-163
<b>Income before taxes</b>		<b>1,447</b>	<b>1,420</b>
Taxes	15	-325	-321
<b>Net income</b>		<b>1,122</b>	<b>1,099</b>
<b>Net income pertaining to:</b>			
Shareholders of Parent Company		1,122	1,099
<b>Net income</b>		<b>1,122</b>	<b>1,099</b>
<b>Earnings per share, SEK</b>	16		
before dilution		10.59	10.45
after dilution		10.59	10.44

## Consolidated statement of comprehensive income

January 1– December 31, SEKm	Note	2024	2023
<b>Net income</b>		<b>1,122</b>	<b>1,099</b>
<b>Other comprehensive income</b>			
<b>Items that have been carried over or can be carried over to net income</b>			
Foreign currency translation		373	-109
Cash flow hedges		-48	35
Net investment hedge		35	11
Tax on components in other comprehensive income	15	-1	-20
<b>Items that cannot be carried over to net income</b>			
Revaluation of defined-benefit pension plans		4	-41
Tax pertaining to items that cannot be carried over to net income	15	-1	8
<b>Other comprehensive income</b>		<b>363</b>	<b>-115</b>
<b>Comprehensive income</b>		<b>1,484</b>	<b>984</b>
<b>Comprehensive income pertaining to:</b>			
Shareholders of Parent Company		1,484	984
<b>Comprehensive income</b>		<b>1,484</b>	<b>984</b>

## Consolidated balance sheet

Per December 31, SEKm	Note	2024	2023
<b>Assets</b>			
Intangible assets	17	8,651	4,887
Tangible assets	18, 22	2,339	2,122
Long-term receivables		16	7
Deferred tax receivables	15	359	281
<b>Total fixed assets</b>		<b>11,365</b>	<b>7,297</b>
Inventories	19	2,155	2,300
Tax receivables		46	199
Accounts receivable	20	764	706
Prepaid expenses and accrued income		106	199
Other receivables		116	172
Cash and cash equivalents	26	405	94
<b>Total current assets</b>		<b>3,592</b>	<b>3,669</b>
<b>Total assets</b>		<b>14,957</b>	<b>10,966</b>

Per December 31, SEKm	Note	2024	2023
<b>Equity and liabilities</b>			
<b>Equity</b>	21		
Share capital		1	1
Other capital contributed		3,690	2,923
Reserves		1,078	719
Profit brought forward including net income		3,326	3,206
<b>Total equity</b>		<b>8,095</b>	<b>6,849</b>
<b>Liabilities</b>			
Long-term interest-bearing liabilities	22, 23	4,301	2,038
Provision for pensions	12	212	205
Deferred income tax liabilities	15	666	399
<b>Total long-term liabilities</b>		<b>5,178</b>	<b>2,642</b>
Short-term interest-bearing liabilities	22, 23	77	136
Accounts payable		746	649
Tax liabilities		51	78
Other liabilities		106	51
Accrued expenses and deferred income	24	625	513
Provisions	25	78	49
<b>Total short-term liabilities</b>		<b>1,683</b>	<b>1,475</b>
<b>Total liabilities</b>		<b>6,862</b>	<b>4,117</b>
<b>Total equity and liabilities</b>		<b>14,957</b>	<b>10,966</b>

Information about the Group's pledged assets and contingent liabilities is provided in notes 29 and 30.

## Consolidated statement of changes in equity

SEKm	Equity attributable to shareholders of Parent Company					Total equity
	Share capital	Other capital contributed	Translation reserve	Hedge reserve	Profit brought forward including net income	
<b>Opening balance, January 1, 2023</b>	<b>1</b>	<b>2 644</b>	<b>788</b>	<b>13</b>	<b>3,107</b>	<b>6,553</b>
<b>Comprehensive income</b>						
Net income	—	—	—	—	1,099	1,099
Other comprehensive income	—	—	-110	28	-33	-115
<b>Comprehensive income</b>	<b>0</b>	<b>0</b>	<b>-110</b>	<b>28</b>	<b>1,066</b>	<b>984</b>
<b>Transactions with the Group's owners</b>						
Dividend	—	—	—	—	-967	-967
New issue of shares	0	273	—	—	—	273
Warrants	—	6	—	—	—	6
<b>Total contribution from owners</b>	<b>0</b>	<b>279</b>	<b>0</b>	<b>0</b>	<b>-967</b>	<b>-688</b>
<b>Closing balance equity, December 31, 2023</b>	<b>1</b>	<b>2,923</b>	<b>678</b>	<b>41</b>	<b>3,206</b>	<b>6,849</b>
<b>Opening balance, January 1, 2024</b>	<b>1</b>	<b>2,923</b>	<b>678</b>	<b>41</b>	<b>3,206</b>	<b>6,849</b>
<b>Comprehensive income</b>						
Net income	—	—	—	—	1 122	1 122
Other comprehensive income	—	—	397	-38	4	363
<b>Comprehensive income</b>	<b>0</b>	<b>0</b>	<b>397</b>	<b>-38</b>	<b>1,125</b>	<b>1,484</b>
<b>Transactions with the Group's owners</b>						
Dividend	—	—	—	—	-1,004	-1,004
New issue of shares	0	757	—	—	—	757
Warrants	—	9	—	—	—	9
<b>Total contribution from owners</b>	<b>0</b>	<b>766</b>	<b>0</b>	<b>0</b>	<b>-1 004</b>	<b>-238</b>
<b>Closing balance equity, December 31, 2024</b>	<b>1</b>	<b>3,690</b>	<b>1,076</b>	<b>2</b>	<b>3,326</b>	<b>8,095</b>

The translation reserve and hedge reserve are included in the item Reserves under equity in the balance sheet.

## Consolidated statement of cash flow

January 1– December 31, SEKm	Note	2024	2023
<b>Operating activities</b>	26		
Income before taxes		1,447	1,420
Adjustments for items not included in cash flow		282	303
Paid income taxes		-188	-509
<b>Cash flow from operating activities prior to changes in working capital</b>		<b>1,541</b>	<b>1,214</b>
<b>Cash flow from changes in working capital</b>			
Increase (-)/Decrease (+) in inventories		492	801
Increase (-)/Decrease (+) in receivables		112	-74
Increase (+)/Decrease (-) in liabilities		165	-91
<b>Cash flow from operating activities</b>		<b>2,310</b>	<b>1,850</b>
<b>Investing activities</b>			
Acquisition of subsidiaries		-2,837	—
Acquisition of intangible assets		0	—
Acquisition of tangible assets		-264	-251
Divestment of tangible assets		1	0
<b>Cash flow from investing activities</b>		<b>-3,099</b>	<b>-251</b>
<b>Financing activities</b>			
New issue of shares		0	273
Dividend		-1,004	-967
Warrants		9	6
Borrowings		6,738	3
Debt repaid		-4,641	-995
<b>Cash flow from financing activities</b>		<b>1,102</b>	<b>-1,679</b>
<b>Net cash flow</b>		<b>313</b>	<b>-80</b>
Cash and cash equivalents at beginning of year		94	176
Effect of exchange rates on cash and cash equivalents		-2	-2
<b>Cash and cash equivalents at end of year</b>		<b>405</b>	<b>94</b>

## Parent Company income statement

January 1– December 31, SEKm	Note	2024	2023
Other operating revenue	8	23	21
Administrative expenses		-60	-84
<b>Operating income</b>	9, 11, 12	<b>-37</b>	<b>-62</b>
<b>Profit from financial items:</b>	14		
Profit from participations in Group companies		550	600
Other interest income and similar profit/loss items		157	164
Interest expense and similar profit/loss items		-173	-178
<b>Income after financial items</b>		<b>497</b>	<b>524</b>
Appropriations	27	90	120
<b>Income before taxes</b>		<b>587</b>	<b>644</b>
Taxes	15	-8	-9
<b>Net income</b>		<b>579</b>	<b>634</b>

## Parent Company statement of comprehensive income

January 1– December 31, SEKm	Note	2024	2023
Net income		579	634
<b>Other comprehensive income</b>			
Other comprehensive income		—	—
<b>Comprehensive income</b>		<b>579</b>	<b>634</b>

## Parent Company balance sheet

Per December 31, SEKm	Note	2024	2023
<b>Assets</b>			
<b>Fixed assets</b>			
<b>Financial fixed assets</b>			
Participations in Group companies	28	1,757	1,000
Receivables from Group companies	32	5,759	3 499
Deferred tax receivables		8	7
Other long-term receivables		29	25
<b>Total financial fixed assets</b>		<b>7,552</b>	<b>4,530</b>
<b>Total fixed assets</b>		<b>7,552</b>	<b>4,530</b>
<b>Current assets</b>			
Receivables from Group companies	32	745	721
Other current receivables		13	10
Cash and bank balances		0	0
<b>Total current assets</b>		<b>757</b>	<b>731</b>
<b>Total assets</b>		<b>8,309</b>	<b>5,261</b>

Per December 31, SEKm	Note	2024	2023
<b>Equity and liabilities</b>			
<b>Equity</b>	21		
<b>Restricted equity</b>			
Share capital		1	1
<b>Non-restricted equity</b>			
Share premium reserve		1,494	1,098
Profit brought forward		—	—
Net income		579	634
<b>Total equity</b>		<b>2,074</b>	<b>1,734</b>
<b>Long-term liabilities</b>			
Provisions for other pensions		38	32
Liabilities to credit institutions	23	4,143	1,903
Liabilities to Group companies	32	0	0
<b>Total long-term liabilities</b>		<b>4,181</b>	<b>1,935</b>
<b>Short-term liabilities</b>			
Liabilities to credit institutions	23	0	0
Liabilities to Group companies	32	1,928	1,546
Other short-term liabilities		30	15
Accrued expenses and deferred income	24	97	31
Provisions	25	0	0
<b>Total short-term liabilities</b>		<b>2,054</b>	<b>1,592</b>
<b>Total equity and liabilities</b>		<b>8,309</b>	<b>5,261</b>

## Parent Company statement of changes in equity

SEKm	Share capital	Share premium reserve	Profit brought forward	Net income	Total equity
<b>Opening balance, January 1, 2023</b>	<b>1</b>	<b>1,102</b>	<b>0</b>	<b>684</b>	<b>1,786</b>
<b>Comprehensive income</b>					
Net income	—	—	—	634	634
<b>Total comprehensive income</b>	<b>0</b>	<b>0</b>	<b>0</b>	<b>634</b>	<b>634</b>
Appropriation of profits	—	—	684	-684	0
New issue of shares	0	273	—	—	273
Dividend	—	-277	-690	—	-967
Warrants	—	—	6	—	6
<b>Closing balance equity, December 31, 2023</b>	<b>1</b>	<b>1,098</b>	<b>0</b>	<b>634</b>	<b>1,734</b>
<b>Opening balance, January 1, 2024</b>	<b>1</b>	<b>1,098</b>	<b>0</b>	<b>634</b>	<b>1,734</b>
<b>Comprehensive income</b>					
Net income	—	—	—	579	579
<b>Total comprehensive income</b>	<b>0</b>	<b>0</b>	<b>0</b>	<b>579</b>	<b>579</b>
Appropriation of profits	—	—	634	-634	0
New issue of shares	0	757	—	—	757
Dividend	—	-361	-643	—	-1 004
Warrants	—	—	9	—	9
<b>Closing balance equity, December 31, 2024</b>	<b>1</b>	<b>1,494</b>	<b>0</b>	<b>579</b>	<b>2,074</b>

## Parent Company cash flow statement

January 1– December 31, SEKm	Note	2024	2023
<b>Operating activities</b>	26		
Income before taxes		587	644
Adjustments for items not included in cash flow		-550	-600
Dividend received		600	650
Paid income taxes		0	0
<b>Cash flow from operating activities prior to changes in working capital</b>		<b>637</b>	<b>694</b>
<b>Cash flow from changes in working capital</b>			
Increase (-)/Decrease (+) in receivables		-82	-45
Increase (+)/Decrease (-) in liabilities		86	31
<b>Cash flow from operating activities</b>		<b>641</b>	<b>680</b>
<b>Investing activities</b>		<b>—</b>	<b>—</b>
<b>Financing activities</b>			
New issue of shares		—	273
Dividend		-1,004	-967
Warrants		9	6
Borrowings		6,738	—
Debt repaid		-4,537	-900
Debt repaid/borrowings to subsidiaries		-1,847	907
<b>Cash flow from financing activities</b>		<b>-641</b>	<b>-680</b>
Net cash flow		0	0
Cash and cash equivalents at beginning of year		0	0
<b>Cash and cash equivalents at end of year</b>		<b>0</b>	<b>0</b>

# Notes for Parent Company and Group

Note	Page
1 Significant accounting policies	95
2 Assessments and assumptions	99
3 Measurement of financial assets and liabilities	100
4 Financial risk management	101
5 Business combinations	104
6 Revenue	105
7 Segment accounting	105
8 Other operating revenue	106
9 Audit fees	106
10 Average number of employees and gender distribution in company management	106
11 Remuneration of employees	107
12 Provision for pensions	109
13 Expenses divided by type of cost	110
14 Net financial items	110
15 Taxes	111
16 Earnings per share	112
17 Intangible assets	113
18 Tangible assets	114
19 Inventories	115
20 Accounts receivable	115
21 Specific disclosures regarding equity	115
22 Leases	116

Note	Page
23 Interest-bearing liabilities	117
24 Accrued expenses and deferred income	117
25 Provisions	117
26 Cash flow statement	118
27 Appropriations	119
28 Participations in subsidiaries	119
29 Pledged assets	120
30 Contingent liabilities	120
31 Events after the balance sheet date	120
32 Related-party transactions	120

All amounts are in million Swedish kronor (SEKm) unless otherwise stated.

## NOTE 1

### Significant accounting policies

#### General information

Thule Group AB (publ), Corp. Reg. No. 556770-6311, is a Swedish registered, limited liability company with its registered office in Malmö, Sweden. The shares of Thule Group are listed on the Nasdaq Stockholm Large Cap list. The consolidated financial statements for the fiscal year January 1 to December 31, 2024 comprise Thule Group AB (Parent Company) and its subsidiaries.

The annual and consolidated accounts were approved for publication by the Board of Directors and the CEO & President on April 4, 2025.

The consolidated income statement, statement of comprehensive income, and the balance sheet, and the Parent Company income statement and balance sheet are subject to approval by the Annual General Meeting on April 29, 2025.

The consolidated financial statements were prepared in accordance with the International Financial Reporting Standards (IFRS), issued by the International Accounting Standards Board (IASB) as adopted by the EU. In addition, the Swedish Corporate Reporting Board's recommendation RFR 1 Supplementary Accounting Rules for Groups was applied. The Parent Company applies the same accounting policies as the Group except in cases listed below in the section "Parent Company accounting policies."

Refer to Alternative performance measures and other financial definitions on page 140 for alternative performance measures.

#### Basis of preparation of the consolidated financial statements

The Parent Company's functional currency is SEK, which is also the presentation currency for the Parent Company and the Group. This means that the financial statements are presented in SEK. All amounts, unless otherwise stated, are rounded to the nearest million.

Assets and liabilities are recognized at historical cost, except for certain financial assets and liabilities, and contingent considerations that are measured at fair value. Financial assets and liabilities measured at fair value consist of derivatives. A defined-benefit pension liability is recognized at the present value of the defined-benefit liability.

The preparation of the financial statements in accordance with IFRS requires management to make assessments and estimates, as well as assumptions, that affect the application of the accounting policies and the amounts of assets, liabilities, revenue and expenses recognized. The actual outcome may differ from these estimates and assessments.

Estimates and assumptions are reviewed regularly. Changes in estimates are recognized in the period in which the change is made if the change only affects that period, or in the period in which the change is made and future periods if the change affects the period in question and future periods. Assessments made by management when applying IFRS that have a significant effect on the financial statements and estimates made that may involve material adjustments in

the following year's financial statements are described in detail in Note 2. The accounting policies presented below have been consistently applied to all periods presented in the consolidated financial statements, unless otherwise stated below.

### Amended accounting policies resulting from amended IFRS

Amended IFRSs that became effective from January 1, 2024 have had no material impact on the Group's accounting.

### Standards, amendments and interpretations not yet applied

The Group is reviewing the impact of IFRS 18 Presentation and Disclosure in Financial Statements, which will become effective from January 1, 2027. Other new and amended IFRSs adopted by the IASB that will be applied in the future are not expected to have any significant impact on the company's financial statements.

### Classification

Fixed assets essentially comprise amounts that are expected to be recovered or paid more than twelve months after the balance sheet date, while current assets essentially comprise amounts expected to be recovered or paid within twelve months from the balance sheet date.

Long-term liabilities essentially comprise amounts that, at the end of the reporting period, the Group has an unconditional right to choose to pay more than twelve months after the end of the reporting period. If no such right should exist at the end of the reporting period, or if the liability is held for trading or is expected to be settled within the normal business cycle, the liability is recognized as a current liability.

### Operating segment reporting

An operating segment is part of the Group that conducts business operations from which it generates revenue and incurs expenses and for which independent financial information is available. Furthermore, the earnings of an operating segment are followed up by the company's chief operating decision-maker, the CEO, and the company management for evaluating performance and for allocating resources to the operating segment.

### Consolidated financial statements

The consolidated financial statements include the Parent Company and its subsidiaries. Subsidiaries are companies over which Thule Group AB has

controlling influence. Controlling influence exists if Thule Group AB has power over the investee, is exposed to or has rights to variable returns from its involvement, and has the ability to use its power over the investee to affect the amount of the returns. Shares that potentially carry voting rights and any de facto control are taken into account in assessing the existence of a controlling influence.

Subsidiaries are recognized in accordance with the purchase method. This method entails that the acquisition of a subsidiary is considered to be a transaction whereby the Group indirectly acquires the subsidiary's assets and assumes its liabilities. The acquisition analysis determines the fair value of the acquired identifiable assets and assumed liabilities, as well as any non-controlling interests, on the acquisition date.

Subsidiaries are fully consolidated from the acquisition date until the controlling influence ends. In cases where the subsidiary's accounting policies are not the same as the Group's accounting policies, adjustments were made to the Group's accounting policies. Losses attributable to non-controlling interests are also allocated if the non-controlling interest is negative.

### Elimination of intra-Group transactions

Intra-Group receivables and liabilities, revenue or costs and unrealized gains or losses arising from intra-Group transactions are eliminated in their entirety when preparing the consolidated financial statements.

### Transactions in foreign currency

Transactions in foreign currency are translated to the functional currency at the exchange rate on the date of the transaction. The functional currency is the currency in the primary financial environments in which the Group companies operate their business. Monetary assets and liabilities in foreign currency are translated to the functional currency at the exchange rate that applies on the balance sheet date. Exchange rate differences arising on translation are recognized through profit or loss. Non-monetary assets and liabilities that are recognized at historic cost are translated using the exchange rate at the date of the transaction. Non-monetary assets and liabilities measured at fair value are translated to the functional currency using the exchange rate on the date that fair value was determined. Exchange rate differences on operating receivables and operating liabilities are included in operating income, while exchange rate differences on financial receivables and liabilities are classified as financial items.

### Translation of foreign subsidiaries

Assets and liabilities in foreign operations, including goodwill and other consolidated surplus and deficit values, are translated from the foreign operation's functional currency to the Group's presentation currency, SEK, at the existing exchange rate on the balance sheet date. Revenue and expenses in foreign operations are translated to SEK using an average exchange rate that is an approximation of the exchange rates prevailing on each individual transaction date.

Translation differences that arise in currency translations of foreign operations are recognized in other comprehensive income and accrued in a separate component in equity, called the translation reserve. When a foreign operation is divested, accumulated translation differences attributable to the business are realized, at which time they are reclassified from the translation reserve in equity to net income.

### Net investment in a foreign operation

Monetary long-term receivables from foreign operations for which settlement is not planned or will likely not occur in the foreseeable future, are, in practice, part of the company's net investment in the foreign operations. Exchange rate differences arising on the monetary long-term receivable are recognized in other comprehensive income and accrued as a separate component in equity, called a translation reserve. When a foreign operation is divested, the accrued exchange rate differences attributable to monetary long-term receivables are included in the accrued translation differences that are reclassified from the translation reserve in equity to net income.

### Revenue

Revenue is measured based on the compensation specified in the contract with the customer. The Group recognizes revenue when control of a product or service is transferred to the customer. All revenue recognition takes place at one point in time. The Group's revenue is mainly attributable to goods. Sales of products to retailers and distributors normally have short delivery times. Control of the goods passes to customers when these have been delivered and accepted by the customer. In conjunction with delivery of the products, invoices are normally prepared with customary payment terms depending on the product category and geographic market. Some contracts entitle the customer to discounts and certain contracts allow the customer to return goods under specific circumstances. For contracts that allow customers to return goods, revenue is recognized to the extent

that it is highly likely that a substantial reversal of recognized revenue will not arise. Discounts and volume discounts affect the transaction price continuously.

### Leases

The Group recognizes a right-of-use asset and a lease liability on the commencement date of a lease. The right-of-use asset is initially recognized at cost, which comprises the initial value of the lease liability plus any lease payments paid on or prior to the commencement date and plus any initial direct costs. The right-of-use asset is depreciated on a straight-line basis from the commencement date to the earlier of the end of the asset's useful life and the lease term, which for the Group is normally the end of the lease term. In less usual cases, where the cost of the right-of-use asset reflects the Group's intention to exercise an option to purchase the underlying asset, the asset is depreciated until the end of its useful life. Right-of-use assets are included under the balance sheet item Tangible assets.

The lease liability – which is allocated to long-term and short-term components – is initially measured at the present value of the remaining lease payments over the estimated lease term. The lease term comprises the non-terminable period with the addition of further periods in the agreement if, on the commencement date, it is deemed reasonably certain that this option will be exercised. Lease liabilities are included in the respective balance sheet items long-term interest-bearing liabilities and short-term interest-bearing liabilities.

The lease payments are normally discounted at the Group's incremental borrowing rate, which in addition to the Group's credit risk, reflects the respective lease term, currency and quality of the underlying asset as collateral.

Lease payments are allocated between repayment of the liability and interest payments. The interest expense is recognized in profit or loss over the lease term so as to produce a fixed rate of interest on the remaining balance of the lease liability for each period.

The lease liability for the Group's premises with index-linked rent are calculated on the rent payable at the end of each reporting period. At this point in time, the liability is adjusted together with a corresponding adjustment to the carrying amount of the right-of-use asset. The liability and the asset value are adjusted in a corresponding manner in conjunction with any reassessment of the lease term.

This is done when the last date for terminating the lease of the premises in the previously assessed lease term has passed or, alternatively, when significant events occur or circumstances materially change in a

manner within the Group's control, and which impact the assessment of the lease term.

Leases with a term of 12 months or less, or with an underlying asset of low value, are not recognized as right-of-use assets and lease liabilities. Lease payments for these leases are recognized as costs in a straight line over the lease term.

### Financial revenue and expenses

Financial revenue and expenses comprise interest income on bank deposits and receivables and interest-bearing securities, interest expense on loans, exchange rate differences and the results from derivatives used in the financial operations.

Interest income on receivables and interest expense on liabilities are calculated using the effective interest rate method.

The effective interest is the interest rate that makes the present value of all estimated future receipts and disbursements during the expected fixed-rate period equal to the carrying amount of the receivables or liabilities. Interest income and interest expense include allocated transaction costs and any discounts, premiums and other differences between the original carrying amount of the receivables and liabilities and the amount that is settled on maturity and the estimated future receipts and disbursements during the contract period.

### Taxes

Income tax includes both current tax and deferred tax. Income tax is recognized through profit or loss, except when the underlying transaction is recognized in other comprehensive income or in equity, whereby the associated tax effects are recognized directly in other comprehensive income or equity. Current tax is tax that is to be paid or received in the current year, using tax rates that are decided or decided in practice on the balance sheet date. Current tax also comprises current tax adjustments for prior periods. Deferred tax is calculated using the balance-sheet method, based on temporary differences between carrying amounts and tax bases of assets and liabilities. Temporary differences are not recognized in consolidated goodwill, nor are differences attributable to participations in subsidiaries that are not expected to be reversed in the foreseeable future. The measurement of deferred tax is based on how underlying assets and liabilities are expected to be recovered or settled. Deferred tax is calculated using the tax rates and tax rules established or decided in practice on the balance sheet date.

Deferred tax receivables relating to deductible temporary differences and loss carryforwards are

recognized only to the extent that it is probable that they will be utilized. The value of the deferred tax receivables is reduced when it is no longer considered likely that they can be utilized. Any additional income tax relating to the dividend is recognized at the same date as the dividend is recognized as a liability.

### Financial instruments

Financial instruments recognized in the balance sheet include assets such as cash and cash equivalents, loans and accounts receivable and derivatives. The liability side includes accounts payable, loans and derivatives. A financial asset or financial liability is recognized in the balance sheet when the company becomes a contracting party in accordance with the instrument's contractual conditions. A receivable is recognized when the company has performed and a contractual obligation exists for the counterparty to pay, even if an invoice has not yet been sent. A liability is recognized when the counterparty has performed and a contractual obligation exists for the company to pay, even if an invoice has not yet been received. A financial asset is derecognized from the balance sheet when the contractual rights are realized, expire or the company loses control of them. The same applies to a portion of a financial asset. A financial liability is derecognized from the balance sheet when the contractual obligation is met or extinguished in another manner. The same applies to portions of a financial liability. A financial asset and a financial liability are offset and recognized at a net amount in the balance sheet only when a legal right exists to offset the amounts and there is an intent to settle the items in a net amount or simultaneously realize the asset and settle the liability.

With the exception of derivatives, the acquisition or disposal of financial assets is recognized when the transaction is completed (cash settlement approach). Derivatives are recognized when an agreement has been entered into (trade date accounting).

### Classification and measurement

Financial instruments are initially recognized at cost corresponding to the instrument's fair value plus transaction costs for all financial instruments except those that belong in the measured at FVTPL category, which are measured at fair value excluding transaction costs. The classification determines how the financial instrument is measured after initial recognition as described below. The classification of financial assets that are debt instruments is determined by the business model of the portfolio in which the financial asset is included and the nature of the contractual cash flows. Thule

Group's business model for all such financial assets aims to collect the principal amount and any interest accrued on the principal. The contractual cash flows from these assets consist solely of principal amounts and interest, and accordingly are classified as financial assets measured at amortized cost.

All financial liabilities are classified under amortized cost except derivatives, which are classified as FVTPL.

Derivatives are initially measured at fair value, meaning that transaction costs are charged to net income for the period. After initial recognition, derivatives are recognized in the manner described below. If the derivative is used for hedge accounting and this is effective, then changes in the value of the derivative are recognized on the same line in net income for the year as the hedged item. When the derivative is part of a cash flow hedge and the hedged item has as yet not impacted the result, the value changes are recognized in other comprehensive income and accumulated in the hedge reserve in equity. Even if hedge accounting is not applied, the result from derivatives is recognized as revenue or expense in operating income or in net financial items based on the purpose of the derivative and how its use is related to an operating or a financial item. For hedge accounting, the ineffective portion is recognized in the same manner as changes in the value of the derivative that is not used for hedge accounting. If hedge accounting is not applied when using interest rate swaps, then the interest coupon is recognized as interest and other changes in the value of the interest rate swap are recognized as other financial revenue or other financial expense.

### Financial assets at fair value through profit or loss

Assets in this category are continually measured at fair value with value changes recognized through profit or loss. This category comprises two sub-categories: obligatory recognition at fair value and other financial assets that the Group has initially decided to place in this category identified as recognized at fair value. Financial instruments in this category are continuously measured at fair value, with changes in value recognized through profit and loss. The first sub-group includes derivatives with a positive fair value, with the exception of derivatives that are an identified and effective hedging instrument.

The Group has only used assets in the obligatory recognition at fair value sub-category.

### Financial assets at amortized cost

The category includes accounts receivable, short-term receivables and cash and cash equivalents. Cash

and cash equivalents comprise cash and immediately available funds at banks and similar institutions, and short-term liquid investments that have a term of less than three months from the date of acquisition and have limited risk for value fluctuations. Accounts receivable are recognized after deduction of expected credit losses. Discounting is not applied because of the short term, which is why the amortized cost corresponds to the nominal value.

### Financial liabilities at fair value through profit or loss (FVTPL)

This category comprises two sub-groups: financial liabilities subject to obligatory recognition at FVTPL and other financial liabilities that the Group has decided to place in this category. The first category includes the Group's derivatives with negative fair value except for derivatives that are an identified and effective hedging instrument. Changes in fair value are recognized through profit or loss. The Group only uses the category for derivatives.

### Financial liabilities at amortized cost

Loans and other financial liabilities, for example, accounts payable, are included in this category. The liabilities are initially recognized at fair value and thereafter at amortized cost through application of the effective-interest method.

### Derivatives and hedge accounting

The Group's derivatives have been acquired to financially secure risks for interest rate, raw material and exchange rate exposures that the Group is exposed to. To meet the IFRS 9 requirements for hedge accounting, an economic relationship must exist with the hedged item.

Moreover, the hedge is required to effectively offset the value changes or cash flows pertaining to the hedged item, hedging documentation must have been prepared and the credit risk is not permitted to dominate value changes in the hedging instrument. Gains and losses for hedging are recognized through profit or loss at the same time period that gains and losses are recognized for the hedged entries. Hedge accounting is applied for loans used as hedging instruments for currency hedging of the translation risk for net investments in foreign operations, for transaction exposure in foreign currency and to hedge the cash flow risk of interest payments.

### Receivables and liabilities in foreign currency

Currency forward contracts are used to hedge receivables or liabilities against exchange rate risk.

Hedge accounting is not used to protect against exchange rate risk since a financial hedge is reflected in the accounting in that both the underlying receivable or liability and the hedging instrument are recognized at the exchange rate on the balance sheet date and exchange rate fluctuations are recognized through profit or loss. Exchange rate fluctuations for receivables and liabilities are recognized in operating income, while exchange rate fluctuations for financial receivables and liabilities are recognized in net financial items.

### Hedging of forecast sale/purchases in foreign currency

Currency forward contracts used for hedging a highly probable forecast sale/purchase in foreign currency are measured at fair value in the balance sheet. Changes in value for the period that comprise an effective hedge are recognized in other comprehensive income and the accumulated changes in value in a specific component of equity (hedge reserve) until the hedged flow affects net income, at which point the hedging instrument's accumulated change in value is reclassified to operating income. Ineffectiveness is recognized through profit or loss on an ongoing basis.

### Cash flow hedging against interest rate risk

Interest rate swaps are used for hedging against uncertainty in highly probable forecast interest rate flows for borrowing at variable interest rates, where the company receives a variable interest rate and pays a fixed interest rate. The Group applies hedge accounting.

Interest rate swaps are measured at fair value in the balance sheet. Interest coupons are continuously recognized through profit or loss as part of interest expenses, whereby the cash flows from hedging instruments meet the cash flows from the hedged item.

To the extent they comprise an effective hedge, the unrealized changes in the fair value of interest rate swaps are recognized in other comprehensive income and are included as part of the hedge reserve until the hedged item affects net income and as long as the criteria for hedge accounting are met. Any ineffectiveness is recognized in net financial items on an ongoing basis.

### Hedging exchange rate risk in foreign net investments

Investments in foreign subsidiaries (net assets including goodwill) have, to some extent, been hedged by borrowing in foreign currency that was translated

at the closing day rate on the balance sheet date. Translation differences on hedging instruments for the period are recognized in other comprehensive income to the extent that the hedging is effective, and accumulated changes are recognized in a specific component of equity (translation reserve). This neutralizes translation differences that affect other comprehensive income when the Group is consolidated.

### Tangible assets

Tangible assets in the Group are recognized at cost less accumulated depreciation and any impairment losses. The cost includes the purchase price and expenses directly attributable to the asset in order to make it operational and ready for use as intended with the acquisition. Borrowing costs that are directly attributable to the purchase, construction or production of assets that take considerable time to complete for intended use or sale are included in the cost. Tangible assets that consist of components with various useful lives are treated as separate components of tangible assets. The carrying amount of tangible assets is removed from the balance sheet when it is scrapped or divested or when there is no future financial benefits expected from the use or scrapping/divestment of the asset. Gains or losses arising on the divestment or scrapping of an asset comprise the difference between the sales price and the carrying amount of the asset, less direct selling expenses. Gains and losses are recognized in operating income.

Additional expenses are added to the cost only if it is likely that future financial benefits associated with the asset will accrue the Group and the cost can be calculated in a reliable manner. All other additional expenses are recognized as costs in the period in which they arise. An additional expense is added to the cost if the expense is for replacement of identifiable components or related parts. Even in situations where a new component is created, the expense is added to the cost. Any carrying amounts of replaced components, or parts of components, that have not been depreciated are scrapped and expensed in conjunction with the replacement. Repairs are regularly expensed.

### Intangible assets

#### Goodwill

Goodwill is measured at cost less any accumulated impairment losses. Goodwill is distributed to the Group's operating segments which make up the Group as a whole and the need for impairment is tested annually.

**Other intangible assets**

Other intangible assets acquired by the Group are recognized at cost less accumulated amortization and any impairment losses. Expenses for internally generated goodwill and brands are recognized through profit or loss as a cost when incurred. As a result of the acquisition of Quad Lock, customer relations, IP and brands have been added. The estimated lives are 10 and 15 years respectively. Brands are not amortized and are instead tested for impairment at least annually.

Payroll expenses that are directly attributable to the purchase, construction or production of assets that take considerable time to complete for intended use or sale are included in the cost.

Cost of system development and research and development are only recognized as an asset in the balance sheet if the product or process is technically and commercially usable and the company has sufficient resources to complete development and then use or sell the intangible asset.

Other product development expenses are recognized through profit or loss as costs when incurred. The majority of the Group's development expenses are attributable to the maintenance and development of products and are recognized through profit or loss when incurred.

**Depreciation/amortization**

**Principles of depreciation for tangible assets**

Useful lives	Group	Parent Company
Buildings and land improvements	35–40 years	—
Plant and machinery	7–15 years	—
Equipment, tools, fixtures and fittings	3–7 years	—

Depreciation takes place on a straight-line basis over the estimated useful life of the asset. Land is not depreciated. Leased assets are also depreciated over the estimated useful life or, if shorter, over the contracted lease period. The Group applies component

depreciation, which means that the estimated useful life of the components is the basis for depreciation. The residual value and useful life of an asset is determined annually.

**Principles of amortization for intangible assets**

Useful lives	Group	Parent Company
Capitalized development expenses	5–10 years	—
IT systems	5–7 years	—
Customer relations	10 years	—
Intellectual property rights	15 years	—
Other intangible assets	5–10 years	—

Goodwill and other intangible assets with an indeterminate useful life or that are still not ready to be used, are tested for impairment annually or as soon as indications appear indicating that the asset in question has decreased in value.

Intangible assets with definite useful lives are amortized from when they are available for use.

Amortization is recognized through profit or loss straight-line over the estimated useful lives of the intangible assets. The residual value and useful life of an asset is determined annually.

**Inventories**

Inventories are measured at the lowest of cost and net realizable value. The cost of inventories is calculated by the first-in, first-out principle (FIFO) and includes expenses from the acquisition of the inventory assets and the transportation of them to their current place and condition. For manufactured goods and work in progress, the cost includes a reasonable share of indirect expenses based on normal capacity. Net realizable value is the estimated sales price in the ordinary course of business, less estimated cost of completion and sale.

**Impairment**

At each balance-sheet date, the carrying amount of the Group's assets is tested to determine whether there is an indication for a need for impairment. If evidence exists, the asset's recoverable amount is calculated. The recoverable amount of goodwill and other intangible assets with indeterminate useful lives is calculated annually. IAS 36 is used for impairment losses of assets other than financial assets and financial guarantees, which are recognized according to IFRS 9, assets held for sale and disposal groups, which are recognized according to IFRS 5, inventories and deferred tax receivables. The carrying amount of the excluded assets listed above is calculated according to the respective standard.

An impairment loss is recognized if the recoverable amount is lower than the carrying amount. An impairment loss is charged to profit or loss.

The recoverable amount is the higher of fair value less selling expenses and the value-in-use. When determining the value-in-use, future cash flows are discounted using a discount factor that takes into consideration risk-free interest and the risk associated with the specific asset. For an asset that does not generate essential cash flows, irrespective of other assets, the recoverable amount of the cash-generating unit that the asset belongs to is calculated. A cash-generating unit is primarily

performed for goodwill and then other assets in the unit are amortized proportionally. All financial assets, except those in the financial asset category that are measured at fair value through profit or loss, are tested for impairment. For each reporting date, the Group calculates the expected credit losses (ECLs) pertaining to a financial asset or group of financial assets over their remaining lifetime. All financial assets subject to the impairment rules are short-term, and accordingly, the Group has chosen to apply the simplified model in which ECLs are recognized for the remaining lifetime of the assets from the date of initial recognition. The ECL levels are based on customers' payment history, together with loss data for the same period. Historical losses are then adjusted to take into account current and forward-looking information on macroeconomic factors that may impact customers' ability to pay. Accounts receivable and contract assets are written off when no reasonable expectation exists of reimbursement. Indicators of no reasonable expectation of recouping the claim include, inter alia, that the debtor fails with the repayment plan or that contractual payments are significantly delayed.

Credit losses on accounts receivable and contract assets are recognized as loan losses – net of operating income.

**Earnings per share**

The earnings per share calculation is based on the consolidated net income attributable to the shareholders of Parent Company and the weighted average number of shares outstanding during the year. When calculating earnings per share after dilution, earnings are adjusted as well as the average number of shares in order to take into consideration the impact from the dilutive potential common shares.

**Remuneration of employees**

**Pensions**

The majority of the Group's pension obligations are met through continuous payments to independent insurance companies that administer the plans, known as defined-contribution pension plans. The responsibility for the amount of future pension payments lies with the external insurance companies. The Group has no further responsibility than paying the premium. A pension expense, which corresponds to the contributions paid, is continuously recognized for defined-contribution pension plans. The expense is recognized in the period in which the employee performed the services to which the contribution refers. Some of the Group's subsidiaries in Sweden have defined-benefit plans that are unfunded.

These defined-benefit pension plans include a commitment regarding future pension benefits, the amount of which is determined by such factors as final salary and service period. The employer bears all material risks for meeting this commitment. The Group's net obligation for defined-benefit plans is calculated separately for each plan by estimating the future remuneration that the employees have earned through their employment in both present and earlier periods; this remuneration is discounted to present value.

The discount rate used by the Group to calculate the defined-benefit pension liabilities in Sweden comprises the market interest rate on the balance sheet date of Swedish mortgage bonds with a term corresponding to the duration of the Swedish pension obligations. The calculation is performed by a qualified actuary using the Projected Unit Credit Method. The special employer's contribution is part of actuarial assumptions and is therefore recognized as a portion of net obligations. The portion of special employer's contribution that is calculated on the basis of the Pension Obligation Vesting Act for legal entities is recognized, for reasons of simplification, as an accrued expense instead of as a part of net obligations. Actuarial gains and losses may arise when determining the present value of the obligation. These will arise when the actual result differs from the previously made assumption or when assumptions are changed. Revaluation effects are recognized in other comprehensive income. Other retirement pensions according to ITP/ITPK in Sweden are guaranteed for the Group through premium payments to Alecta. According to a statement from the Swedish Corporate Reporting Board, UFR10, this must be reported as a multi-employer defined-benefit plan. For the 2024 fiscal year, the Group did not have access to information from Alecta that made it possible to recognize this plan as a defined-benefit plan. Accordingly, the plan has been recognized as a defined-contribution plan.

**Bonuses**

A provision is recognized for the anticipated cost of profit share and bonus payments when the Group has a contractual or informal duty to make such payments as a result of services received from employees, the conditions for remuneration are deemed to be fulfilled and the obligation can be reliably calculated.

**Remuneration if employment is terminated**

A cost for remuneration in connection with the termination of employment is recognized earliest when the Group can no longer retract the offer to the employees or when the Group recognizes restructuring costs.

**Share-based remuneration**

Within the framework of the share-based incentive programs, participants have the possibility to receive a retention bonus in the form of a gross salary supplement from the company that in total corresponds to the amount paid by the participant for the warrants. Such payment is conditional upon continued employment in the Group at the time of payment. The cost for the above, including social security costs, has been recognized in profit or loss in the vesting period.

**Provisions**

A provision differs from other liabilities in that there is uncertainty about the time of payment and the amount of settlement. A provision is recognized in the balance sheet when there is an existing legal or informal obligation resulting from a past event and when it is probable that an outflow of financial resources will be required to settle the obligation and a reliable estimate of the amount can be made. Provisions are made based on the best estimate of what will be required to settle the existing obligation on the balance sheet date.

**Contingent liabilities**

A contingent liability is recognized when there is a possible obligation that originates from past events and whose occurrence is only confirmed by one or more uncertain future events or when there is an obligation that is not recognized as a liability or a provision because it is not likely that an outflow of resources will be needed.

**Parent Company accounting policies**

The Parent Company prepares its Annual Report in accordance with the Swedish Annual Accounts Act (1995:1554) and the Swedish Corporate Reporting Board's recommendation RFR 2 Accounting for Legal Entities. RFR 2 stipulates that the Parent Company, in the annual accounts for the legal entity, is to apply all IFRS and statements adopted by the EU to the extent that this is possible within the framework of the Annual Accounts Act and the Pension Obligations Vesting Act and taking into consideration the connection between accounting and taxation. The recommendation stipulates the permissible exceptions from and additions to IFRS. Based on RFR 2, the Parent Company has decided not to apply IFRS 9 and IFRS 16 in the legal entity.

**Amended accounting policies**

Unless otherwise stated below, the Parent Company's accounting policies for 2024 changed in accordance with the amendments described above for the Group.

**Differences between the Group's and the Parent Company's accounting policies**

The differences between the accounting policies of the Group and the Parent Company are stated below. The accounting policies for the Parent Company stated below have been consistently applied in all periods presented in the financial statements of the Parent Company.

**Classification and presentation format**

The income statement and the balance sheet for the Parent Company are presented following the format of the Annual Accounts Act, while the statement of comprehensive income, statement of changes in equity and cash flow statement are based on IAS 1 Presentation of Financial Statements and IAS 7 Statement of Cash Flows. The differences compared with the consolidated financial statements that apply in the Parent Company's income statement and balance sheets primarily comprise reporting of financial revenue and expenses, fixed assets, equity, as well as the presence of provisions as a separate heading in the balance sheet.

**Subsidiaries**

Participations in subsidiaries are recognized in the Parent Company according to the cost method. This means that transaction charges are included in the carrying amount for holdings in subsidiaries. In the consolidated financial statements, transaction costs are recognized directly through profit or loss when they arise, while in the Parent Company, financial fixed assets are measured at cost less any impairment.

**Net investments**

Exchange rate differences on monetary items that comprise part of the Parent Company's net investment in foreign operations are recognized through profit or loss.

**Leased assets**

In accordance with the exception under RFR 2, the Parent Company does not apply IFRS 16. As the lessee, lease payments are recognized in a straight line over the lease term and are therefore not recognized as right-of-use assets and lease liabilities in the balance sheet.

**Anticipated dividends**

Anticipated dividends from subsidiaries are reported in cases where the Parent Company has the exclusive right to determine the size of the dividend and has made a decision on the size of the dividend prior

to publication of the Parent Company's financial statements.

**Taxes**

In contrast to the Group, untaxed reserves in the Parent Company are recognized in the balance sheet without any specification between equity and deferred tax liabilities. Correspondingly, the Parent Company does not specify the portion of appropriations to deferred taxes in the income statement.

**Group contributions**

Group contributions are recognized as appropriations.

**NOTE 2****Assessments and assumptions**

The preparation of the annual accounts and the application of accounting standards are, in some cases, based on assessments, estimates and other assumptions that management considers to be reasonable under the current conditions. For obvious reasons, these assessments and assumptions are based on experiences and expectations of future events. If different assessments and assumptions were made, the results might be different.

**Goodwill**

An assessment is made every year as to whether goodwill requires impairment. Impairment testing is performed through estimation of the recoverable amount. Assumptions about future cash flows and estimates of parameters are made as a basis for the calculation. These are explained in Note 17.

**Business combinations**

In connection with business acquisitions, a number of estimates and assumptions are made for the preparation of the purchase price allocation. Established models for this have been used. Assessments have also been made regarding the useful lives of customer relationships and intellectual property identified in the purchase price allocation, and assumptions and judgments have been made regarding valuation models, interest rates and royalty levels.

**Taxes**

Deferred tax is calculated on the temporary differences between the tax and carrying amounts of liabilities and assets and on loss carryforwards. There are two types of assessments and assumptions in these calculations that can affect the deferred tax recognized. The first is the assessments and assumptions made to determine the carrying amount and, the second, the assessments made to determine the possibility of using existing loss carryforwards on future taxable profits. The budget and strategic plan for future years were also taken into consideration in the assessment of loss carryforwards. For more information, refer to Note 15.

**NOTE 3****Measurement of financial assets and liabilities****Fair value and carrying amounts in the balance sheet.**

Group 2024	Carrying amount							Fair value
	FVTPL	Derivatives used in hedge accounting	Amortized cost	Total	Level 1	Level 2	Level 3	Total
<b>Financial assets at fair value</b>	Obligatory							
Interest rate derivatives	—	3	—	3	—	3	—	3
Currency derivatives	2	10	—	12	—	12	—	12
<b>Total</b>	<b>2</b>	<b>14</b>	<b>0</b>	<b>15</b>	<b>0</b>	<b>15</b>	<b>0</b>	<b>15</b>
<b>Financial assets not measured at fair value</b>								
Accounts receivable	—	—	764	764	—	—	—	764
Cash and cash equivalents	—	—	405	405	—	—	—	405
<b>Total</b>	<b>0</b>	<b>0</b>	<b>1,169</b>	<b>1,169</b>	<b>0</b>	<b>0</b>	<b>0</b>	<b>1,169</b>
<b>Financial liabilities at fair value</b>								
Interest rate derivatives	—	7	—	7	—	7	—	7
Currency derivatives	0	2	—	2	—	2	—	2
<b>Total</b>	<b>0</b>	<b>9</b>	<b>0</b>	<b>10</b>	<b>0</b>	<b>10</b>	<b>0</b>	<b>10</b>
<b>Financial liabilities not measured at fair value</b>								
Bank borrowings	—	—	4,143	4,143	—	—	—	4,143
Overdraft facilities	—	—	—	—	—	—	—	—
Accounts payable	—	—	746	746	—	—	—	746
<b>Total</b>	<b>0</b>	<b>0</b>	<b>4,889</b>	<b>4,889</b>	<b>0</b>	<b>0</b>	<b>0</b>	<b>4,889</b>

**Fair value and carrying amounts in the balance sheet.**

Group 2023	Carrying amount							Fair value
	FVTPL	Derivatives used in hedge accounting	Amortized cost	Total	Level 1	Level 2	Level 3	Total
<b>Financial assets at fair value</b>	Obligatory							
Interest rate derivatives	—	12	—	12	—	12	—	12
Currency derivatives	5	58	—	63	—	63	—	63
<b>Total</b>	<b>5</b>	<b>70</b>	<b>0</b>	<b>75</b>	<b>0</b>	<b>75</b>	<b>0</b>	<b>75</b>
<b>Financial assets not measured at fair value</b>								
Accounts receivable	—	—	706	706	—	—	—	706
Cash and cash equivalents	—	—	94	94	—	—	—	94
<b>Total</b>	<b>0</b>	<b>0</b>	<b>799</b>	<b>799</b>	<b>0</b>	<b>0</b>	<b>0</b>	<b>799</b>
<b>Financial liabilities at fair value</b>								
Interest rate derivatives	—	7	—	7	—	7	—	7
Currency derivatives	24	11	—	34	—	34	—	34
<b>Total</b>	<b>24</b>	<b>18</b>	<b>0</b>	<b>41</b>	<b>0</b>	<b>41</b>	<b>0</b>	<b>41</b>
<b>Financial liabilities not measured at fair value</b>								
Bank borrowings	—	—	1,903	1,903	—	—	—	1,903
Overdraft facilities	—	—	3	3	—	—	—	3
Accounts payable	—	—	649	649	—	—	—	649
<b>Total</b>	<b>0</b>	<b>0</b>	<b>2,554</b>	<b>2,554</b>	<b>0</b>	<b>0</b>	<b>0</b>	<b>2,554</b>

Information is provided below about how fair value is determined for financial instruments that are measured at fair value on the balance sheet. The following three-level hierarchy is used to determine fair value:

**Level 1:** according to prices quoted in an active market for the identical instrument.

**Level 2:** from either direct or indirect observable market information not included in Level 1.

**Level 3:** from inputs unobservable in the market.

The following summarizes the methods and assumptions that are primarily used to determine the fair value of the financial instruments presented above.

### Derivatives

#### Currency

The fair value of a forward contract is determined beginning with quoted rates. The market price, calculated by using the current rate adjusted for the interest rate spread between currencies and number of days, is compared with the contract's rate to determine the fair value.

The market value of currency options is calculated using the Black & Scholes model.

#### Interest rates

The fair value of interest rate swaps is based on an intermediary institution's measurement, whose fairness is tested by discounting estimated cash flows according to the conditions and due dates of the contract, using the market interest rate for identical instruments on the balance sheet date.

#### Accounts receivable and accounts payable

The carrying amount reflects the fair value of accounts receivable and accounts payable with a remaining term of less than 12 months. Accounts receivable and accounts payable with a term exceeding 12 months are discounted when determining fair value.

#### Interest-bearing liabilities

The fair value of financial liabilities that are not derivatives is calculated using future cash flows of principal amounts and interest rates discounted to the current market interest rate on the balance sheet date. The carrying amount agrees with the fair value of the Group's borrowing when the loans have variable interest rates and the credit spread is not such that carrying amount materially deviates from fair value.

## Note 4

### Financial risk management

Thule is continuously exposed to various financial risks through its international operations. Financial risks refer to fluctuations in the company's earnings and cash flow due to changes in exchange rates, interest rate levels, raw material prices, refinancing and credit risks. The Group's finance policy for managing financial risks is prepared by the Board and creates a framework of guidelines and regulations in the form of risk mandates and limits on the financial operations. The Board decides on a finance policy annually. The Group's finance department centrally manages responsibility for the Group's financial transactions and risks. The overall goal of the finance department is to provide cost efficient financing, to map out financial risks that affect the Group, and to minimize negative impacts on the Group's earnings that stem from market risks. The Board's Audit Committee prepares, on behalf of the Board, the practical application of the policy in consultation with the Group's CFO.

### Organization and activities

Thule Group's finance operations are coordinated by the subsidiary Thule Holding AB, which acts as an internal bank for the Group's financial transactions in the currency and interest rate markets.

### Refinancing and liquidity risks

Refinancing and liquidity risks are risks that payment commitment cannot be met due to insufficient liquidity or difficulties in obtaining credit from outside sources. The Group has a rolling eight-week liquidity plan that includes all divisions of the Group. Results are reported regularly on a weekly basis. The plan is updated monthly. The liquidity plan is used to manage liquidity risk and as a tool for following the cash flow from the operational and financial business. In-depth analyses are made against previous years in order to measure trends and noticeable deviations. The objective is for the Group to be able to manage its financial obligations in upturns and downturns with a buffer for unforeseeable expenses and without risking the Group's reputation.

The Group policy is to minimize its borrowing need by centralizing surplus liquidity via the Group's cash pools that have been established by the central finance department. Liquidity risks are centrally managed for the entire Group by the central finance department. The central finance department manages a Group-wide, monthly netting process to minimize the number of payment transactions and thereby related expenses. Cash pools are used to match liquidity surpluses and deficits, and during the year there were cash pools in Sweden, Poland and the US. The central finance department manages liquidity in, as well as between, these cash pools.

Thule Group has entered a new financing agreement that replaces the agreement entered in June 2018. The new financing agreement, which came into effect in the second quarter of 2024, totals EUR 550m and consists of a combination of a revolving credit facility of EUR 470m and a long-term loan of EUR 80m. The revolving credit facility and the long-term loan are contingent on compliance with financial and commercial undertakings, which are tested regularly. The covenants tested quarterly are the leverage ratio and interest coverage ratio.

The Group's fixed-term credit commitments amounted to SEK 6,340m (4,287), which includes a revolving credit facility of SEK 5,394m, a long-term loan of SEK 895m and an overdraft facility of SEK 50m.

Credit facilities	Notional value	Notional value, SEKm	Utilized	Available
Syndicated credit commitments, term until 2027	EUR 235m	2,697	2,554	143
Syndicated credit commitments, term until 2029	EUR 235m	2,697	785	1,912
Long-term loans, term until 2028	EUR 78m	895	895	0
Bilateral credit commitment, term until 2025	SEK 50m	50	0	50
<b>Total</b>		<b>6,340</b>	<b>4,234</b>	<b>2,105</b>
Available cash and cash equivalents				405
<b>Liquidity reserve</b>				<b>2,510</b>

Unutilized credit commitments totaled SEK 2,105m (2,288).

Including cash flows for future interest payments, the Group's financial liabilities amounted to SEK 5,566m (2,950) at year end with a term structure as set out in the following table.

### Term structure of financial liabilities – undiscounted cash flows

2024, SEKm	Total	<1 month	1–3 months	3 months –1 year	1–5 years	>5 years
Long-term liabilities to credit institutions incl. interest payments	4,357	—	—	—	4,357	—
Derivatives – gross settlement	2	0	1	1	—	—
Derivatives – net settlement	7	—	0	3	4	—
Short-term liabilities to credit institutions incl. interest payments	218	—	51	167	—	—
Overdraft facilities	—	—	—	—	—	—
Accounts payable	746	—	746	—	—	—
Lease liabilities	235	0	1	87	128	19

2023, SEKm	Total	<1 month	1–3 months	3 months –1 year	1–5 years	>5 years
Long-term liabilities to credit institutions incl. interest payments	1,928	—	—	—	1,928	—
Derivatives – gross settlement	34	24	3	7	0	—
Derivatives – net settlement	7	0	0	0	7	—
Short-term liabilities to credit institutions incl. interest payments	71	0	21	50	—	—
Overdraft facilities	3	3	—	—	—	—
Accounts payable	649	—	649	—	—	—
Lease liabilities	258	—	1	102	128	26

### Market risk

Market risk is the risk that the fair value of, or future cash flows from, a financial instrument could fluctuate due to changes in market prices. IFRS has divided market risks into three types: exchange rate risk, interest rate risk and other price risks. The market risks that primarily impact the Group consist of interest rate risk, exchange rate risk and commodity price risk. The Group's objective is to manage and control the market risks within established parameters while optimizing earnings through risk-taking within stated limits. The parameters are established with the purpose that the market risks in the short term (up to 12 months) only impact the Group's earnings and position marginally. In the long term, however, lasting changes in exchange rates, interest rates and raw material prices have an impact on consolidated earnings.

Derivatives are only used for economic hedging purposes and not as speculative investments. Thule Group applies hedge accounting, if necessary and if relevant criteria have been met, to remove the accounting mismatch between the hedging instrument and the hedged item. However, where derivatives do not meet the hedge accounting criteria, they are classified as 'held for trading' for accounting purposes and are measured at fair value through profit or loss.

### Exchange rate risk

The risk that fair values and cash flows can fluctuate when the value of currencies changes is called exchange rate risk. The Group is exposed to different types of exchange rate risks.

### Transaction exposure

The largest exposure comes from the Group's sale and purchase in foreign currencies. These exchange rate risks consist of risk in the value fluctuations of financial instruments, accounts receivable or accounts payable, and the exchange rate risk in expected and contractual payment flows. These risks are called transaction exposure.

The Group's total transaction exposure, net, amounts to about SEK 4,846m (3,104) annually. The single most important currency relationship is EUR/SEK, in which the Group has a positive net inflow. The total exposure has increased and the most important currency pairs have changed from last year largely due to the acquisition of Quad Lock. The central finance department is responsible for all hedging to reduce the effect of exchange rate fluctuations.

The Group's transaction exposure and hedged amounts on the balance sheet date distributed by currency were as follows:

#### Transaction exposure and hedged amounts, SEKm

Dec 31, 2024 Currency	Exposure	Hedged amounts – maturity 2025	Exposure after hedge	Average hedged rate
EUR/SEK	1,670	854	816	11.55
CNY/SEK	-269	-126	-143	1.50
PLN/SEK	-266	-35	-231	2.66
EUR/AUD	786	0	786	—
GBP/AUD	432	0	432	—
USD/AUD	-379	0	-379	—
Other	1,045	309	736	—
<b>Total</b>	<b>4,846</b>	<b>1,324</b>	<b>3,523</b>	

Dec 31, 2023 Currency	Exposure	Hedged amounts – maturity 2024	Exposure after hedge	Average hedged rate
EUR/SEK	1,461	826	635	11.70
CNY/SEK	-309	-153	-155	1.45
PLN/SEK	-291	-128	-163	2.56
CNY/CAD	-274	-130	-144	5.28
USD/EUR	-126	-63	-63	0.92
GBP/SEK	201	92	109	13.51
Other	442	134	308	—
<b>Total</b>	<b>3,104</b>	<b>1,525</b>	<b>1,578</b>	

The Group uses currency forward contracts and currency options to optimize its exchange rate risk management.

The fair value of the Group's currency derivatives outstanding (currency forward contracts and currency options) was SEK 8.2m (46.9) as per December 31, 2024. All currency derivatives outstanding fall due in 2025. Hedge accounting is used for currency forward contracts.

### Translation exposure

There are also exchange rate risks in the conversion of assets and liabilities of foreign subsidiaries to the Parent Company's functional currency, called translation exposure. The total translation exposure was SEK 11,228m (4,734). The largest translation exposures were in AUD, USD and EUR. The translation exposure was SEK 5,916m (0) in AUD, SEK 2,175m (1,915) in USD and SEK 1,397m (1,223) in EUR.

The Group's policy is to hedge net investments with external loans but otherwise not to hedge translation exposure. The currency effects that the loans give rise to are recognized as a financial currency effect in the income statement. The currency effect in 2024 was negative SEK 34.8m (positive: 11.0). However, the Group applies hedge accounting and a negative SEK 34.8m (positive: 11.0) of the total of a negative SEK 34.8m (positive: 11.0) was transferred to the translation reserve for net investment hedging.

### Net investment – total effect for 2024

Currency	Net investment – hedged item	External loans	Currency effect of external loans, SEKm	Hedging instruments	Hedging effectiveness	Effective-ness EQ in SEKm	Ineffective-ness in SEKm
EUR	335.1	(328.0)	(34.8)	(328.0)	100%	(34.8)	0.0

The translation impact of the conversion of the liabilities and assets of foreign subsidiaries in 2024 was SEK 397m (negative: 110) after taking into account the effects of hedging.

### Sensitivity analysis – exchange rate risk

Compared with the closing exchange rates applied as per December 31, 2024, a 10 percent strengthening of the SEK against other currencies would have negatively impacted subsidiaries' equity by SEK 1,123m (negative: 473).

A 10 percent strengthening of the SEK against other currencies, compared with the average exchange rates in 2024 (not taking into consideration any correlation between currencies), would mean a negative change in EBITDA of SEK 263.3m (negative: 183.9) (transaction and translation effects). The following table shows the effect broken down by currency:

### Sensitivity analysis for exchange rate risk on EBITDA 2024, SEKm

Currency	Transaction effect	Translation effect	Total
EUR	-256.1	-20.4	-276.5
CAD	-3.3	-23.8	-27.0
GBP	-16.4	-7.1	-23.4
PLN	113.6	-91.4	22.3
CNY	28.4	15.5	43.9
USD	-11.0	-15.2	-26.2
Other	-22.8	46.4	23.6
<b>Total</b>	<b>-167.5</b>	<b>-95.8</b>	<b>-263.3</b>

### Interest rate risk

Interest rate risk is the risk that the value of financial instruments fluctuates due to changes in market interest rates and the risk that changes in the interest rate level will impact the Group's borrowing costs. Interest rate risk can lead to a change in fair values and changes in cash flows. A significant factor that affects the interest rate risk is the fixed-rate period. This interest rate risk is managed by the Group's central finance department. According to the finance policy, the objective of the long-term liability portfolio is for the average fixed-rate period to be between six months and three years. The average fixed-rate period was 11 months (1 year and 8 months) as per December 31, 2024. The maturity structure of the interest rate derivatives outstanding is spread over the period from December 2026 through December 2028. ISDA agreements were signed with all lenders.

The fair value of the Group's interest rate derivatives outstanding (interest rate swaps and interest rate floors) was a negative SEK 4.1m (positive: 5.2) as per December 31, 2024. Hedge accounting is used for interest rate derivatives. The Group does not hedge 100 percent of its loans, and therefore only identifies the proportion of the outstanding loans up to the notional values of the swaps. Swaps outstanding covered 26 percent (45) of the variable loan capital outstanding.

### Sensitivity analysis – interest rate risk

The impact on the Group's results in the form of interest expense during the coming 12-month period in the event of an interest rate uptick/downtick of 1 percentage point on the balance sheet date is SEK -30.9/+30.9m (-10.7/+10.7) – given the interest-bearing liabilities that exist on the balance sheet date.

An interest rate change of +/-1 percentage point on the balance sheet date would result in a change in the market value of interest rate derivatives of SEK +25.9m (+23.7)/-25.6m (-22.7). The change in market value impacts equity if hedge accounting can continue to be applied.

### Hedge accounting

The Group applies hedge accounting for the hedges of three different types of exposures:

Type of exposure	Hedging model	Hedging instruments
Transaction exposure	Cash flow hedge of exchange rate risk	FX forwards
Translation exposure	Hedge of net investment in foreign currency	Foreign currency loans
Interest rate risk	Cash flow hedges of floating rate loans	Interest rate swaps

Hedge effectiveness is determined at the inception of the hedge relationship. When the Group performs hedges, hedge relationships are contracted where the critical terms of the hedging instrument match the terms of the hedged item. Thereafter, the hedged item and the hedging instrument are then assessed on an ongoing basis to ensure that the hedging relationship continues to meet the requirements for hedge accounting. The ongoing assessment of the effectiveness of the hedging relationship is performed through regular monitoring of the critical terms, which comprise the notional value and the currency of the hedging instrument, and the expected cash flows from the hedged item. No hedge ineffectiveness arises as the hedges are fully matched with respect to the critical terms.

The following table presents the impact of the various hedges on profit or loss and the balance sheet.

SEKm, 2024			Market value (carrying amount)				
Type of exposure	Hedging instruments	Nominal values	Financial assets	Financial liabilities	Change in market value recognized in	Hedged item in the balance sheet	Impact on profit or loss
<b>Cash flow hedges*</b>							
Exchange rate risk	FX forwards	1,323.6	10.3	-2.1	Hedge reserve in equity	Future accounts receivable and accounts payable	Operating income 2025
Interest rate risk	Interest rate swaps and floors	1,103.4	3.2	-7.3	Hedge reserve in equity	Long-term loans	Net financial items 2025–2028
<b>Net investment hedge</b>							
Exchange rate risk	Foreign currency loans	3,764.6	—	-34.8	Translation differences in equity	Equity in foreign subsidiaries	Gain/loss on future sale of subsidiaries

\*During the year, SEK 46.9 million was reclassified from the hedge reserve in equity to profit or loss (of which SEK 46.9m pertained to exchange rate risk hedges and SEK 0.0m to interest rate risk hedges). Market values refer entirely to changes in value arising from spot price movements.

SEKm, 2023			Market value (carrying amount)				
Type of exposure	Hedging instruments	Nominal values	Financial assets	Financial liabilities	Change in market value recognized in	Hedged item in the balance sheet	Impact on profit or loss
<b>Cash flow hedges*</b>							
Exchange rate risk	FX forwards	1,525.4	57.8	-10.9	Hedge reserve in equity	Future accounts receivable and accounts payable	Operating income 2024
Interest rate risk	Interest rate swaps and floors	1,073.3	12.0	-6.9	Hedge reserve in equity	Long-term loans	Net financial items 2024–2027
<b>Net investment hedge</b>							
Exchange rate risk	Foreign currency loans	1,104.7	11.0	—	Translation differences in equity	Equity in foreign subsidiaries	Gain/loss on future sale of subsidiaries

\*During the year, a negative amount of SEK 17.6 million was reclassified from the hedge reserve in equity to profit or loss (of which a negative SEK 17.6m pertained to exchange rate risk hedges and SEK 0.0m to interest rate risk hedges). Market values refer entirely to changes in value arising from spot price movements.

### Commodity price risk

Commodity price risk refers to continuously fluctuating prices of input goods from our suppliers and its possible impact on earnings. For the Group, it is primarily fluctuations in aluminum, plastic and steel prices that constitute a significant commodity risk. In 2024, 55 percent (51) of total direct materials consisted of plastic, aluminum and steel. They consist of a number of different subcategories with various degrees of processing that often cannot be tied to a direct market price. Of the three exposures, only aluminum, in principle, is directly associated with a traded market index.

In 2024, the Group purchased raw materials and components for SEK 3,183m (2,828). Total purchases of raw materials amounted to SEK 1,514m (1,413). Direct purchases of raw materials amounted to SEK 930m (862) and indirect purchases of raw materials (share of value added of the total value of raw materials) amounted to SEK 584m (551). Direct purchases of aluminum amounted to SEK 294m (295) and indirect purchases of aluminum amounted to SEK 294m (295). Direct purchases of plastic amounted to SEK 394m (348) and indirect purchases of plastic amounted to SEK 263m (232). Direct purchases of steel amounted to SEK 242m (219) and indirect purchases of steel amounted to SEK 27m (24).

However, a significant portion of the supplier contracts for these categories are indexed, which means that if the market price for a raw material changes, then the Group's purchase prices will increase or decrease. Direct materials amounted to 71 percent (72) of the Group's cost of goods sold.

### Credit risk

The Group's financial operation creates exposure to credit risks. Primarily counterparty risks in connection with receivables from banks arise when purchasing derivatives and deposits to these banks. The exposure can be attributable to surplus values in derivatives. In order to reduce credit risk, the derivatives are spread between different counterparties. The ISDA

agreements permit the offset of derivative assets and derivative liabilities per counterparty, which reduces credit risk. ISDA agreements were signed with all counterparties for settlement of mutual obligations to deliver and pay, and thereby reduce credit risk.

#### Group 2024

SEKm	Financial assets	Financial liabilities
Amount recognized in balance sheet	15.3	9.6
Danske Bank	-1.4	-1.4
Nordea	4.3	4.3
SEB	-0.6	-0.6
Swedbank	0.7	0.7
<b>Amount after netting</b>	<b>18.4</b>	<b>12.7</b>

#### Group 2023

SEKm	Financial assets	Financial liabilities
Amount recognized in balance sheet	75.0	41.4
Danske Bank	-18.1	-18.1
Nordea	-12.1	-12.1
SEB	-9.1	-9.1
Swedbank	-2.1	-2.1
<b>Amount after netting</b>	<b>33.6</b>	<b>0.0</b>

The credit risk in derivatives on the balance sheet date was SEK 15.3m (75.0) and corresponded to the total positive market value of the derivatives. The credit risk in cash and bank balances was SEK 405m and corresponded to the Group's cash and cash equivalents.

#### Credit risk in accounts receivable

Refer to Note 20 Accounts receivable.

#### Net debt

As of December 31, 2024, net debt amounted to SEK 3,961m (2,006).

Net debt consists of the Group's interest-bearing liabilities, including accrued interest and financial derivative liabilities less cash and cash equivalents, interest-bearing short-term receivables and financial derivative assets.

## Note 5

### Business combinations

#### Reacha

At the start of July, Thule Group acquired the German company Reacha (good goods tegernsee GmbH). The company has an innovative product design that makes it possible for people to cycle to the sea or lake with a kayak or SUP (Stand Up Paddleboard) carried on a bike trailer. Operations are based in Germany with the majority of sales in Europe. The purchase consideration was SEK 13m including an estimated earn-out payment. Bike trailers is an attractive and growing segment. Operations will be integrated in Thule's product portfolio and distribution channels. Reacha was consolidated into Thule Group as of July 2024. From the date of the acquisition until December 31, 2024, the company contributed SEK 5m to the Group's revenue and operating income of SEK 1m. If the acquisition had taken place on January 1, 2024, the acquisition would have contributed sales of SEK 9m and operating income of SEK 1m.

Net assets at the acquisition date, SEKm	2024
Intangible assets	12
Tangible assets	0
Operating receivables	2
Cash and cash equivalents	2
Deferred tax	-3
Operating liabilities	-1
Interest-bearing liabilities	-3
	10
Group goodwill	3
Purchase consideration	13

#### Quad Lock

On December 4, the Group completed the acquisition of 100 percent of the shares and votes of the unlisted company Key TopCo Pty Ltd, the owner of Quad Lock. Quad Lock is the global market leader in performance phone mount solutions, giving cyclists, motorcyclists, and other adventurers access to their mobile phones while being active.

The acquisition was completed based on a valuation of AUD 500m, or approximately SEK 3.6 billion, on a cash and debt free basis. The purchase consideration corresponds to a multiple of 10x Quad Lock's LTM EBITDA. The total remuneration for acquired shares was financed through a combination of existing cash and credit facilities (approximately 76 percent of the purchase consideration), newly issued shares in Thule Group (approximately 24 percent, based on the final purchase price which was based on the share price at the acquisition date, December 4, 2024). In addition to the above, there is a deferred performance-based compensation to selected Quad Lock management shareholders (see further below).

Quad Lock was founded in 2011 when its two Australian founders invented a wear-resistant and user-friendly solution to easily mount cell phones on their mountain bikes. The product offering has been expanded at a rapid pace and, today, Quad Lock is the global market leader in performance phone mounts with the market's largest selection of high-quality and robust solutions for enthusiasts of all-terrain biking, motorcycling or driving. Quad Lock has sales in approximately 100 countries, of which about 75 percent are via e-commerce direct to consumers. The head office is based in Melbourne, Australia. Quad Lock also strengthens

Thule Group's position in Asia Pacific, where the share of Thule's revenue increases from approximately 5 to 10 percent through the acquisition. Direct sales to consumers increases from approximately 7 to 15 percent of sales. The acquisition also provides Thule with a customer base including motorcycle enthusiasts, which is Quad Lock's largest segment, as well as expertise in electronics such as the wireless charging of cellphones on motorcycles.

Quad Lock was consolidated into Thule Group as of December 4, 2024. From the date of the acquisition until December 31, 2024, the company contributed SEK 105m to the Group's revenue, an operating income amounting to SEK 21m and EBITDA of SEK 26m. If the acquisition had taken place on January 1, 2024, the acquisition would have contributed sales of SEK 1,421m and operating income of SEK 305m not taking into account transaction costs but including depreciation/amortization of excess values amounting to SEK 36m and an EBITDA of SEK 365m.

Net assets at the acquisition date, SEKm	2024
Intangible assets Total	1,247
– Intellectual property rights	369
– Customer relations	128
– Brand	745
– Other intangible assets	6
Tangible assets	57
Operating receivables	383
Cash and cash equivalents	49
Deferred tax	-240
Operating liabilities	-187
Interest-bearing liabilities	-443
	867
Group goodwill	2,327
Purchase consideration	3,193

The value of acquired intangible assets of SEK 1,241m has been determined preliminarily awaiting the final valuation of these assets.

#### Goodwill

The goodwill value primarily includes technical knowledge and development, geographical and market-related growth potential and synergies with a market leading product portfolio, overlapping customer segments and a growing market for premium phone mounts. No part of the goodwill is expected to be tax deductible.

#### Transaction costs

Acquisition-related expenses amounted to SEK 100m and related to fees to consultants for due diligence, legal advice and assistance in conjunction with the acquisition. These expenses have been recognized as an administrative expense in the consolidated income statement in the fourth quarter of 2024.

Consideration transferred, SEKm	2024
Cash and cash equivalents	2,437
Shares issued (2,105,065 ordinary shares)	757
Purchase consideration	3,193
Refinancing of liabilities	443
Acquired cash and cash equivalents	-49
Purchase consideration on a cash and debt free basis	3,587
Non-cash items	-757
Cash payment	2,830

#### Shares issued

For accounting purposes, the consideration shares have been issued at SEK 359.60 per share, the current price on the transaction date (December 4, 2024). 19,039,487 shares in Quad Lock, with a total value of AUD 106m, or SEK 757m, constitute the total remuneration for the consideration shares and have been paid in kind by the sellers to whom the new shares in Thule Group have been issued.

#### Contingent consideration

The acquisition agreement states that performance-based remuneration is to be issued to previous shareholders in Quad Lock's management. The outcome of the remuneration is conditional on the achievement of financial targets and is conditional on the person remaining in service until June 30, 2027. This item is accounted for separately from the acquisition and has not been recognized at any value at the acquisition date. In subsequent periods, this item will be recognized in accordance with IAS 19. The maximum remuneration can amount to approximately SEK 90m.

#### Other information

The table below demonstrates the seasonal variations of the acquired Quad Lock operations in 2024 in relation both to sales and to EBITDA.

%	2024				
	Q1	Q2	Q3	Q4	Full year
Net sales	18	27	28	27	100
EBITDA	15	26	38	21	100

## Note 6

### Revenue

The Group generates revenue from the sale of products to external customers. Sales are organized in two regions, Region Europe & RoW and Region Americas, and are divided into four product categories: Sport&Cargo Carriers – this category includes roof racks, roof boxes, bike carriers and racks for water and winter sports transported by car and rooftop tents to be mounted on vehicles. Computer and camera bags, hiking backpacks and luggage are recognized under Packs, Bags & Luggage. Bike trailers, strollers, child bike seats, car seats and dog transport are included under the product category Juvenile & Pet. Awnings, bike carriers and tents for RVs and caravans are recognized under RV Products. Quad Lock has been reported separately for 2024, but from 2025 onward will be reported under the product category Packs, Bags & Luggage under the name Bags & Mounts. For further information, refer to Note 7 Segment accounting.

Other revenue primarily pertains to development work conducted for external customers.

Group, SEKm	2024	2023
<b>Revenue from contracts with customers</b>		
<b>Product categories:</b>		
Sport&Cargo Carriers	5,613	5,343
Packs, Bags & Luggage	859	883
RV Products	1,708	1,772
Juvenile & Pet Products	1,226	1,115
Quad Lock	105	—
Other	30	19
<b>Total</b>	<b>9,541</b>	<b>9,132</b>

Geographic markets:	2024	2023
Sweden	335	327
Other Nordic countries	330	283
Germany	2,468	2,470
Other Europe	3,534	3,237
USA	1,849	1,847
Other North America	440	415
Central/South America	180	181
Asia/Pacific Rim	355	326
Rest of World	50	46
<b>Total</b>	<b>9,541</b>	<b>9,132</b>

All revenue recognition takes place at one point in time. Contract assets do not amount to a significant amount in the Group.

## Note 7

### Segment accounting

The Group's operations are divided into operating segments based on the parts of the operations that are followed up by the company's CEO. Thule Group comprises one segment. Though the Group has shared global processes for product development, purchasing, manufacture, logistics and marketing, its sales are managed in two regions, Region Europe & RoW and Region Americas. Internal monthly follow-up focuses on the Group as a whole, in addition to certain geographic sales data, which is presented at other levels than Group level.

Group, SEKm	2024	2023
<b>Sales to customers</b>	<b>9,541</b>	<b>9,132</b>
Region Europe & RoW	7,072	6,682
Region Americas	2,469	2,450

<b>Adjusted EBITDA</b>	<b>1,904</b>	<b>1,763</b>
Depreciation/amortization and impairment	-282	-259
<b>Adjusted operating income</b>	<b>1,622</b>	<b>1,505</b>
Transaction costs from acquisitions	-100	—
<b>Operating income</b>	<b>1,522</b>	<b>1,505</b>
Financial revenue	97	79
Financial expenses	-172	-163
Taxes	-325	-321
<b>Net income</b>	<b>1,122</b>	<b>1,099</b>

Sales are divided into four product categories: Sport&Cargo Carriers, Packs, Bags & Luggage, Juvenile & Pet Products and RV Products. Quad Lock has been reported separately for 2024. For additional information on the various product categories, refer to Note 6 Revenue.

The information presented for the segments' revenue pertains to the geographic areas based on the location of customers. The table is available under Note 6 Revenue. No single customer exceeds 10 percent of external revenue. Information regarding the assets is based on the geographic areas grouped according to the location of the assets.

Fixed assets – Group, SEKm	2024	2023
Sweden	591	539
Other Nordic countries	—	—
Germany	96	93
Other Europe	1,036	953
USA	337	316
Other North America	5	4
Central/South America	1	1
Asia/Pacific Rim	45	1
<b>Total</b>	<b>2,112</b>	<b>1,907</b>

The assets in the above table refer to owned tangible assets.

## Note 8

### Other operating revenue

SEKm	Group		Parent Company	
	2024	2023	2024	2023
Re-invoicing of expenses	—	—	23	21
<b>Total</b>	<b>0</b>	<b>0</b>	<b>23</b>	<b>21</b>

## Note 9

### Audit fees

Audit fees, SEKm	Group		Parent Company	
	2024	2023	2024	2023
Audit PwC	5.0	3.9	1.9	1.2
Audit-related advisory services beyond the scope of the audit assignment PwC	0.1	0.0	0.1	0.0
Tax consultancy PwC	—	0.6	0.0	0.6
Other services PwC	0.8	0.4	0.8	0.4
<b>Total</b>	<b>5.9</b>	<b>5.0</b>	<b>2.8</b>	<b>2.2</b>
Audit, Other	1.1	0.9	—	—
<b>Total</b>	<b>1.1</b>	<b>0.9</b>	<b>—</b>	<b>—</b>

Audit assignments pertain to a review of the Annual Report and accounts, and the administration by the Board of Directors and the CEO, other work assigned to the company's auditors, and advice or other assistance required due to observations made during the review or implementation of such other assignments. Everything else is considered other assignments.

## Note 10

### Average number of employees and gender distribution in company management

Parent Company	2024	Of whom, men	
		2023	2023
Sweden	5	4	6

Subsidiaries	2024	Of whom, men	
		2023	2023
Sweden	638	402	585
Europe	1,544	842	1,433
North America	420	241	445
South America	35	25	35
Asia	55	29	55
Australia	111	73	—
<b>Total subsidiaries</b>	<b>2,803</b>	<b>1,612</b>	<b>2,553</b>
<b>Total</b>	<b>2,808</b>	<b>1,616</b>	<b>2,559</b>

### Gender distribution for Board members and other executive management

Board members, %	2024	Group		Parent Company	
		2023	2024	2023	2023
Women	14	17	43	49	
Men	86	83	57	51	

CEO and other executive management, %	2024	2023	
		2024	2023
Women	27	14	20
Men	73	86	80

## Note 11

### Remuneration of employees

SEKm	Group		Parent Company	
	2024	2023	2024	2023
Salaries and other remuneration	1,286	1,228	32	50
Social security	350	336	12	17
Pension expenses – defined-contribution plans	58	55	7	6
Pension expenses – defined-benefit plans	20	17	–	–
<b>Total</b>	<b>1,715</b>	<b>1,636</b>	<b>52</b>	<b>73</b>

#### Salaries and other remuneration, pension expenses and pension obligations for the Board and executive management

Remuneration and benefits 2024, SEKt	Basic salary incl. changes in vacation pay liability, fees	Variable remuneration	Pension expenses	Other remuneration	Severance pay	Total
<b>Chairman of the Board</b>						
Hans Eckerström	1,525	–	–	–	–	<b>1,525</b>
<b>Board members</b>						
Sandra Finér	341	–	–	–	–	<b>341</b>
Paul Gustavsson	379	–	–	–	–	<b>379</b>
Anders Jensen	449	–	–	–	–	<b>449</b>
Sarah McPhee	556	–	–	–	–	<b>556</b>
Heléne Mellquist	119	–	–	–	–	<b>119</b>
Johan Westman	449	–	–	–	–	<b>449</b>
Helene Willberg	715	–	–	–	–	<b>715</b>
<b>CEO</b>						
Mattias Ankarberg	9,306	2,982	2,786	140	–	<b>15,213</b>
<b>Other executive management</b> (14 individuals)	<b>27,776</b>	<b>6,473</b>	<b>4,633</b>	<b>2,472</b>	<b>–</b>	<b>41,355</b>
<b>Total</b>	<b>41,615</b>	<b>9,455</b>	<b>7,418</b>	<b>2,612</b>	<b>–</b>	<b>61,101</b>

Pension obligations for the CEO Mattias Ankarberg amounted to SEK 2,997 thousand December 31. Pension obligations for other executive management amounted to SEK 8,119 thousand (6,601). Other senior executives in the above table includes remuneration to Jonas Lindqvist, Rickard Andersson, Fredrik Erlandsson and Kajsa von Geijer for the period up to the end of their employment. Remuneration to other members of group management has been included from the date they joined Group management or from the date they joined the group.

Remuneration and benefits 2023, SEKt	Basic salary incl. changes in vacation pay liability, fees	Variable remuneration	Pension expenses	Other remuneration	Severance pay	Total
<b>Chairman of the Board</b>						
Hans Eckerström	1,489	–	–	–	–	<b>1,489</b>
<b>Board members</b>						
Mattias Ankarberg*	268	–	–	–	–	<b>268</b>
Anders Jensen	322	–	–	–	–	<b>322</b>
Sarah McPhee	521	–	–	–	–	<b>521</b>
Heléne Mellquist	471	–	–	–	–	<b>471</b>
Therese Reuterswård	104	–	–	–	–	<b>104</b>
Johan Westman	426	–	–	–	–	<b>426</b>
Helene Willberg	661	–	–	–	–	<b>661</b>
<b>CEO*</b>						
Mattias Ankarberg	3,796	1,105	990	59	–	<b>5,950</b>
Magnus Welander	6,074	2,543	2,107	135	8,820	<b>19,679</b>
<b>Other executive management</b> (6 individuals)	<b>16,369</b>	<b>3,314</b>	<b>3,794</b>	<b>2,310</b>	<b>3,068</b>	<b>28,856</b>
<b>Total</b>	<b>30,501</b>	<b>6,962</b>	<b>6,891</b>	<b>2,504</b>	<b>11,888</b>	<b>58,747</b>

\* Mattias Ankarberg assumed the role of CEO and President for Thule Group on August 9, 2023 (some work and handover has taken place before this date) and stepped down from the Board as of the same date. Magnus Welander was CEO until the date on which Mattias Ankarberg took over the post.

**Remuneration of the Board**

According to a resolution of the General Meeting, fees to the members of the Board, excluding Committee work, are to be paid as follows: SEK 1,445,000 to the Chairman of the Board and SEK 455,000 to each of the Board members elected by the Meeting.

The Chairman of the Audit & Sustainability Committee is to receive remuneration of SEK 275,000 for Committee work, while SEK 110,000 is to be paid to each of the other members. The Chairman of the Remuneration Committee is to receive remuneration of SEK 95,000 for Committee work, while SEK 50,000 is to be paid to each of the other members. Expensed remuneration is presented in the table above.

**Guidelines for remuneration to the CEO and other executive management**

Thule Group applies the following guidelines for remuneration of senior executives, resolved at the General Meeting held on April 27, 2023 for the period until the 2027 AGM.

The executives covered by the guidelines are the CEO and the other members of the Group Management. The basis for the remuneration to members of the Group Management shall be the sustainability of the company within a commercial financial development, organizational structure to provide for a professionalism that is adapted to the company's strategic objectives and also to provide the company with the adequate competence and resources at any given time. The remuneration to the Group Management shall comprise of fixed salary on market terms and variable remuneration, intended to stimulate the fulfillment of objectives of the company's commercial and sustainable development, pension benefits and competitive other benefits. The total remuneration shall be on market terms, be competitive and reflect the individual's performance and responsibilities.

For employments governed by rules other than Swedish, pension benefits and other benefits may be duly adjusted for compliance with mandatory such rules or established local practice, taking into account, to the extent possible, the overall purpose of these guidelines.

In accordance with separate resolutions by the general meeting, long-term, share-based incentive programs are established in the company. These programs are excluded from these guidelines. The purpose of the share-based incentive programs is, among other things, to stimulate a sustainable and favorable value development of Thule Group's share that will benefit the shareholders. The basis of the incentive programs is the company's strategic plan

and sustainable development and constitute an incentive to fulfill the growth objectives that the company stipulated in its strategic three-year plan.

Fixed salary shall be on market terms. The variable remuneration may compromise of annual variable cash remuneration and long-term variable cash remuneration. Annual variable cash remuneration shall be measured during a calendar year and be conditional upon the fulfillment of predefined and measurable objectives, whereby EBIT results are weighted between 40–90 percent, sales development or other financial targets such as cash flow, capital tied up or similar are weighted between 0–50 percent and sustainability development objectives with 10–50 percent. Set personal targets may correspond to a maximum of 20 percent. The annual variable remuneration shall amount to a maximum of 75 percent of the fixed annual salary for the CEO and 60 percent for the other senior executives.

If and to the extent the general meeting does not resolve to implement long-term, share-based incentive programs, variable remuneration may also consist of a long-term variable cash remuneration that is implemented annually. To participate in the scheme for long-term variable remuneration, an own investment is required by the participant. Long-term variable remuneration must be measured over a period of at least three calendar years and be conditional upon the fulfillment of predefined and measurable objectives during the measurement period, and the payment is conditional on a predetermined fulfillment of objectives within sustainability. The long-term variable remuneration must, with regard to each measurement period, be amount to a maximum of 150 percent of the fixed salary.

The terms and conditions for variable remuneration shall be designed so that the Board of Directors may choose, under exceptional economic circumstances, to limit or refrain from payment of variable remuneration if such a measure is considered reasonable.

For members of the Group Management, pension benefits, including health insurance (Sw: sjukförsäkring), shall be premium defined. Variable cash remuneration shall not qualify for pension benefits. The pension premiums for premium defined pension shall amount to not more than 35 percent of the annual fixed salary.

Other benefits may include, among other things, life insurance, medical insurance (Sw: sjukvårdsförsäkring), company car and fuel benefit. Such benefits may amount to a maximum of 15 percent of the annual fixed salary.

Severance payments may be made when the employment is terminated by Thule Group. Members

of the Group Management shall have a period of notice of not more than 12 months, in combination with severance pay corresponding to a maximum of 12 months fixed salary. No severance payment will be made when the employment is terminated by the employee.

In the preparation of the Board of Directors' proposal for these remuneration guidelines, remuneration and employment conditions for employees of the company have been taken into account, in that information on the employees' total income, the components of the remuneration and increase and growth rate over time has constituted part of the basis of decision in the Remuneration Committee and the Board of Directors in evaluating the reasonableness of the guidelines and the limitations following from these. The development of the gap between the remuneration to executives and remuneration to other employees will be disclosed in the remuneration report.

The Board of Directors has established a Remuneration Committee. The Committee's tasks include preparing the Board of Directors' decision to propose guidelines for executive remuneration. The Board of Directors shall prepare a proposal for new guidelines at least every four years and submit it to the AGM. The guidelines shall be in force until new guidelines are adopted by the general meeting. The Remuneration Committee shall also monitor and evaluate programs for variable remuneration for the Group Management, the application of the guidelines for executive remuneration as well as the current remuneration structures and compensation levels in the company. The members of the Remuneration Committee are independent of the company and its management. The CEO and other members of the Group Management do not participate in the Board of Directors' processing of and resolutions regarding remuneration-related matters in so far as they are affected by such matters.

The Board of Directors may temporarily resolve to derogate from the guidelines resolved on by the AGM, if in a specific case there is special cause for the derogation and a derogation is necessary to serve the company's long-term interests and sustainability, or to ensure the company's financial viability.

**Remuneration of the CEO**

Remuneration is paid to the CEO in the form of basic salary, variable remuneration, pension and other benefits. Basic salary for Mattias Ankarberg amounts to SEK 8 880 thousand per year. Variable remuneration can amount to a maximum of 75 percent of basic salary. Any bonus payments and the amount of bonus are related to the degree of fulfillment of

annual, predefined financial and sustainability targets. The financial targets are linked to sales growth and EBIT, and the sustainability targets to the company's sustainability initiatives.

A mutual period of notice of six months applies to the CEO. Full salary and other employment benefits are paid during the period of notice, regardless of whether or not the CEO has an obligation to work. Severance pay corresponding to 12 monthly salaries is also paid if employment is terminated by the company.

In 2024, the pension benefit amounted to 30 percent of basic salary. To the extent that premiums are not fully tax deductible for the company, excess premiums are to be agreed as direct pension, insured through endowment insurance pledged to the CEO.

**Other executive management**

Remuneration is paid in the form of basic salary, variable remuneration, pension and other benefits. For other executive management, variable remuneration may amount to between 40 and 60 percent of basic salary. Any bonus payments and the amount of bonus are determined based on the degree of fulfillment of annual, predefined financial targets, sustainability targets and individual targets. The financial targets are linked to sales growth and EBIT. The sustainability targets are linked to the company's sustainability initiatives and individual targets based on personal performance.

Other executive management has a mutual period of notice of six months. Full salary and other employment benefits are paid during the period of notice. Severance pay corresponding to between 6 and 12 monthly salaries is also paid if employment is terminated by the company.

Pension benefits at 27–35 percent of basic salary are paid for executive management employed in Sweden. To the extent that premiums are not fully tax deductible for the company, excess premiums are to be agreed as direct pension, insured through endowment insurance pledged to the senior executive. Pension benefits at maximum of 4 percent of basic salary can be payable for executive management employed in the US. Pension benefits at 6,84 percent of basic salary are payable for executive management employed in Belgium.

**Remuneration Committee**

The Remuneration Committee is to assist the Board by submitting proposals on remuneration issues and continuously monitoring and evaluating remuneration structures and levels for the CEO and other executive management.

**Incentive program****Share-based incentive program 2023/2026, 2024/2027 and 2025/2028**

The Annual General Meeting 2023 resolved in line with the Board's proposal to introduce an incentive program for executive management and key employees of Thule Group. The program entails that a maximum of 2,778,000 subscription warrants, distributed in equal parts in three series, shall be issued to Thule Group AB's wholly owned subsidiary Thule AB for further transfer to the participants. Series 2023/2026 was implemented in 2023 and a total of 388,370 warrants were acquired by 36 participants. The warrants were transferred at a price of SEK 26.72 per warrant, which corresponded to the fair market price calculated by an external party at the time of transfer. The warrants can be exercised to subscribe for shares between June 15 and December 15, 2026.

The second series, 2024/2027, was implemented in 2024 and a total of 326,009 warrants were acquired by 28 participants. The warrants were transferred at a price of SEK 29.77 per warrant, which corresponded to the fair market price calculated by an external party at the time of transfer. The warrants can be exercised to subscribe for shares between June 15 and December 15, 2027 and the exercise price per share has been set at SEK 379.94, which corresponds to 120 percent of the volume-weighted average price according to Nasdaq Stockholm's official price list during the five trading days immediately preceding the transfer. The so-called roof price has been set at SEK 519.57, which corresponds to 164.1 percent of the same average share price. This means that if the market price of the company's share exceeds the roof price when the option is exercised, the exercise price shall be increased accordingly. The third series, 2025/2028, will be implemented during 2025, but no later than June 15, 2025. Within the frameworks of the respective series, participants may receive a retention bonus in the form of a gross salary supplement from the company that corresponds in total to the amount paid by the participant for the warrants, conditional upon continued employment at the time of payment and that the participant has not terminated the employment. The maximum dilution effect if all 2,778,000 subscription warrants are exercised is approximately 2.7 percent.

Executive management's holdings of warrants in Thule Group AB are presented below.

Warrants 2024	Opening balance, warrants outstanding	Warrants acquired during the year	Warrants exercised during the year	Warrants that matured /canceled during the year	Warrants bought back during the year	Closing balance, warrants outstanding
<b>Group management</b>						
<b>CEO</b>						
Mattias Ankarberg	110,000	100,772	—	—	—	210,772
<b>Other executive management</b>						
Rickard Andersson*	20,000	—	—	—	-20,000	0
Helena Dino	—	9,000	—	—	—	9,000
Fredrik Erlandsson*	1,000	—	—	—	-1,000	0
Andreas Häggglund	4,000	4,000	—	—	—	8,000
Aden Johnson	—	7,000	—	—	—	7,000
Daniel Larsson	29,940	26,872	—	—	—	56,812
Toby Lawton	40,000	36,949	—	—	—	76,949
Filip Van der Linden	10,000	7,000	—	—	—	17,000
Tina Liselius	29,940	26,872	—	—	—	56,812
Karl-Johan Magnusson	26,500	10,000	—	—	—	36,500
Catharina Paulcén	—	20,000	—	—	—	20,000
<b>Other participants</b>						
Other participants	116,990	77,544	—	—	—	194,534
Unsold warrants	0	599,991	—	—	—	599,991
<b>Total</b>	<b>388,370</b>	<b>926,000</b>	<b>0</b>	<b>0</b>	<b>-21,000</b>	<b>1,293,370</b>

\*Fredrik Erlandsson and Rickard Andersson stepped down from their positions during the year.

As of December 31, 2024, the number of redeemable warrants was 0. The market value of the warrants was calculated by using an established valuation model (Black-Scholes) with the following preconditions. The market value below refers to the market value at the time of the transfer.

**Market value per series:**

2023/2026	SEK 26.72
2024/2027	SEK 29.77

**Valuation conditions for 2024/2027:**

<b>Exercise price</b>	SEK 379.94 (based on 120% of the volume-weighted average price according to Nasdaq Stockholm's official price list for shares in the company during the period May 27 through May 31, 2024), with a roof price of SEK 519.57, which corresponds to 164.1% of the above volume-weighted average share price.
<b>Volatility</b>	30% (based on statistical data for comparable, listed companies).
<b>Risk-free interest</b>	2.67% (based on Swedish government bonds with matching maturities to the warrants).

No dividend estimate is applied in the valuation, instead the option terms entail conversion of the exercise price and the number of shares to which each option entitles subscription for at each dividend date. Recalculations to take into account dividends paid resulted in the following current exercise and roof prices:

Series:	2023/2026	2024/2027
Exercise price, SEK	330.10	374.50
Roof level, SEK	455.00	514.10
Number of shares per warrant	1.03	1.01

## Note 12 Provision for pensions

### Group

Post-employment remuneration, such as pensions and other remuneration, is usually paid through regular payments to independent authorities or agencies that thus take over the obligations to the employees, meaning through defined-contribution plans.

Other pension plans in the Group comprise defined-benefit plans where the obligation remains with the Group. Defined-benefit plans primarily exist in Sweden through the ITP plan in accordance with the PRI System (retirement pension).

The ITP plan is encompassed by collective agreement between the Confederation of Swedish Enterprise and PTK.

The defined-benefit ITP plan (ITP2) primarily comprises a retirement pension for life. It is based on final salary on retirement. The benefit amounts to 10 percent of final salary on incomes of up to 7.5 income base amounts, 65 percent of final salary on incomes of between 7.5 and 20 income base amounts and 32.5 percent of final salary on incomes of between 20 and 30 income base amounts. No retirement pension benefit is paid on incomes over 30 income base amounts. Companies in the Group have decided to insure the ITP2 retirement pension by making provisions to an account for pensions in the balance sheet, alongside credit insurance with PRI Pensionsgaranti. In addition to the ITP2 retirement pension, the plan also includes a family pension, disability pension, complementary retirement pension (ITPK) and group life insurance benefits (TGL) for which companies in the Group continuously pay premiums to Alecta/Collectum. According to a statement from the Swedish Corporate Reporting Board (UFR 10), the defined-benefit ITP in Alecta is defined as a multi-employer defined-benefit plan. For the 2024 fiscal year, the Group did not have access to information from Alecta that made it possible to recognize these pension obligations as defined-benefit. Accordingly, these obligations are recognized as defined-contribution pension obligations.

A surplus or a deficit with Alecta may entail a refund to the Group or lower or higher future contributions. At the end of the year, Alecta's surplus in the form of the collective consolidation level was 162 percent (157). The collective consolidation level comprises the market value of the manager's assets as a percentage of the insurance commitments calculated according to the manager's actuarial calculation assumptions.

For the portion of the ITP plan in Sweden that the Group recognizes as a liability via credit insurance with PRI, the Group is exposed to interest rate risk and long lifetime risk.

For defined-benefit plans, the Group's expenses and present value of outstanding obligations are calculated on the balance sheet date using actuarial calculations. The table below provides information about the most significant actuarial assumptions, recognized expenses during the fiscal year and the value of obligations at the end of the period.

Assumptions in actuarial calculations, %	2024	2023
Discount rate	3.30	3.10
Expected rate of salary increase, above inflation	1.65	1.75
Rate of inflation	1.80	1.65

The discount rate used by the Group to calculate the defined-benefit pension liabilities in Sweden comprises the market interest rate on the balance sheet date of Swedish mortgage bonds with a term corresponding to the duration of the Swedish pension obligations.

For Sweden, the mortality assumption, DUS 23, is used. The average remaining life expectancy for a 65-year-old man today is 22 (22), and the average remaining life expectancy for a 65-year-old woman today is 24 (24).

In addition to the impact from amended actuarial assumptions such as a change in the discount rate, etc., actuarial gains and losses arose due to an adjustment of experience-based effects. Experience-based effects refer to actual salary increases compared with assumed increases, actual personnel turnover rate compared with the assumed personnel turnover rate, etc. The distribution between actuarial gains and losses that are dependent on changes in assumptions and experience-based gains and losses are shown below.

	Group	
Changes in assumptions, SEKm	2024	2023
Gains (-) and losses (+) due to changes in financial assumptions	-4	26
Gains (-) and losses (+) due to changes in demographic assumptions	0	4
Experienced-based gains (-) and losses (+)	-1	12
<b>Recognized in other comprehensive income</b>	<b>-4</b>	<b>41</b>

	Group	
Carrying amount of defined-benefit pension plans, SEKm	2024	2023
Present value of unfunded obligations	212	205
<b>Provision for pensions</b>	<b>212</b>	<b>205</b>

	Group	
Changes in present value of obligation for defined-benefit plans, SEKm	2024	2023
Obligation per January 1	205	156
Service cost during current period	14	11
Interest expense	6	6
Pension payments	-9	-10
Actuarial gains (-) and losses (+)	-4	41
<b>Obligation per December 31</b>	<b>212</b>	<b>205</b>

In 2025, the costs are expected to amount to SEK 20m. At the end of 2024, the average duration of the Swedish pension obligation was approximately 22.5 (22) years.

The present value of the Group's pension obligations is sensitive to changes in the discount rate (interest rate risk). A decline in the discount rate will lead to the present value of the obligations increasing and an increase in the discount rate will lead to the present value of the obligation declining. The table presents the impact on the present value of the obligations in the event of a 1.0-percentage-point increase and decrease in the discount rate.

SEKm	Group	
1.0 percent increase in discount rate	-35	
1.0 percent decrease in discount rate	45	

	Group	
Expenses for defined-benefit plans, SEKm	2024	2023
Service cost during current period	14	11
Interest expense	6	6
<b>Recognized in income statement</b>	<b>20</b>	<b>17</b>

	Group	
Pension expense recognized in the following lines in income statement, SEKm	2024	2023
Selling expenses	14	11
Financial expenses	6	6
<b>Total</b>	<b>20</b>	<b>17</b>

#### Defined-contribution pension plans

In Sweden, the Group has defined-contribution pension plans for employees that are entirely funded by the companies.

Abroad, there are defined-contribution plans that are partly funded by the subsidiaries and partly covered through contributions paid by employees. Payments to these plans are carried out on a regular basis according to the rules of the respective plan.

	Group		Parent Company	
Defined-contribution pension plans, SEKm	2024	2023	2024	2023
Expenses for defined-contribution plans	58	55	7	6
<b>Total</b>	<b>58</b>	<b>55</b>	<b>7</b>	<b>6</b>

## Note 13

### Expenses divided by type of cost

SEKm	Group	
	2024	2023
Changes in inventory of finished products and work in progress	146	465
Raw materials and manufacturing supplies	-4,047	-4,354
Expenses for remuneration of employees	-1,839	-1,762
Depreciation/amortization	-282	-259
Other expenses	-1,998	-1,717
<b>Total expenses for goods sold, sales and administration</b>	<b>-8,020</b>	<b>-7,627</b>

## Note 14

### Net financial items

SEKm	Group		Parent Company	
	2024	2023	2024	2023
Profit from participations in Group companies	—	—	550	600
Interest income	78	58	157	164
Net exchange rate fluctuations	20	21	0	0
<b>Financial revenue</b>	<b>97</b>	<b>79</b>	<b>707</b>	<b>764</b>
Interest expenses	-156	-156	-102	-120
Other financial expenses	-9	-2	-71	-59
Interest expenses on defined-benefit pension obligations	-6	-6	0	0
<b>Financial expenses</b>	<b>-172</b>	<b>-163</b>	<b>-173</b>	<b>-178</b>
<b>Net financial items</b>	<b>-75</b>	<b>-84</b>	<b>534</b>	<b>586</b>

Of interest expenses SEK 93m (104) pertained to the category of financial liabilities recognized at amortized cost and SEK 20m (16) pertained to the category of financial liabilities measured at fair value. Interest coupons for financial derivatives are netted, meaning that both receipts and payments are recognized as interest expense.

## Note 15

### Taxes

Recognized in income statement, SEKm	2024	Group		Parent Company	
		2023	2024	2023	2024
<b>Current tax expense/tax revenue</b>					
Tax expense for the year	-336	-286	-8	-9	
<b>Deferred tax expense/tax revenue</b>					
Deferred tax pertaining to temporary differences and loss carryforwards	10	-36	0	0	
<b>Total recognized tax expense (-)/tax revenue (+)</b>	<b>-325</b>	<b>-321</b>	<b>-8</b>	<b>-9</b>	

Effective tax rate reconciliation, SEKm	2024 (%)	Group		2023 (%)	2023
		2024	2023		
Income before taxes		1 447			1 420
Tax according to current tax rates for Parent Company	20.6	298	20.6		293
Impact of other tax rates on foreign subsidiaries	1.0	15	2.6		37
Non-deductible expenses	0.7	9	2.1		30
Non-taxable income	-0.6	-9	-0.2		-2
Increase in loss carryforwards without corresponding capitalization of deferred tax	0.0	0	0.0		0
Utilization of previously non-capitalized loss carryforwards	0.0	0	-1.5		-21
Tax attributable to previous years	0.1	2	-0.3		-4
Effect of amended tax rates/regulations	0.0	0	0.0		0
Other	0.7	10	-0.8		-11
<b>Recognized effective tax</b>	<b>22.5</b>	<b>325</b>	<b>22.6</b>		<b>321</b>

The effective tax rate for 2024 amounted to 22.5 percent (22.6).

Effective tax rate reconciliation, SEKm	2024 (%)	Parent Company		2023 (%)	2023
		2024	2023		
Income before taxes		587			644
Tax according to current tax rates for Parent Company	20.6	121	20.6		133
Non-taxable income	-19.3	-113	-19.2		-124
<b>Recognized effective tax</b>	<b>1.3</b>	<b>8</b>	<b>1.4</b>		<b>9</b>

#### Recognized in statement of comprehensive income

Group, SEKm	2024			2023		
	Before tax	Taxes	After tax	Before tax	Taxes	After tax
Foreign currency translation	373	-4	370	-109	-10	-119
Hedge reserve	-48	10	-38	35	-7	28
Net investment hedge	35	-7	28	11	-2	9
Actuarial gains and losses	4	-1	4	-41	8	-33
<b>Other comprehensive income</b>	<b>365</b>	<b>-2</b>	<b>363</b>	<b>-104</b>	<b>-11</b>	<b>-115</b>

#### Recognized in balance sheet

Deferred tax receivables and liabilities pertain to the following:

Group, SEKm	Deferred tax receivables		Deferred tax liabilities		Net	
	2024	2023	2024	2023	2024	2023
Tangible assets	11	14	-29	-21	-18	-8
Intangible assets	9	14	-274	-16	-265	-2
Inventories	58	54	0	0	58	54
Receivables	5	2	0	0	5	2
Liabilities	112	72	-4	0	108	72
Other	19	5	0	0	19	5
Loss carryforwards	145	120	—	—	145	120
Tax allocation reserves	—	—	-359	-361	-359	-361
<b>Tax receivables/liabilities</b>	<b>359</b>	<b>281</b>	<b>-666</b>	<b>-399</b>	<b>-307</b>	<b>-118</b>

Deferred tax on leases has been netted in the above tables. Gross deferred tax receivables amounted to SEK 50m (53) and deferred tax liabilities amounted to SEK 52m (52).

Changes in deferred tax, net, have been recognized as follows.

SEKm	2024	2023
Deferred tax, net, on January 1	-118	-73
Recognized in profit or loss:	10	-36
of which, temporary differences	1	-45
of which, loss carryforwards	9	9
Recognized in other comprehensive income	14	0
Business combinations	-243	—
Currency effect	30	-8
<b>On December 31</b>	<b>-307</b>	<b>-118</b>

#### Non-recognized deferred tax receivables

Deductible temporary differences and loss carryforwards for which no deferred tax receivables have been recognized in the balance sheet:

Group, SEKm	2024	2023
Tax deficit	668	714
	<b>668</b>	<b>714</b>

Deferred tax receivables have not been recognized for the above tax deficit, since it is unlikely the Group will utilize them for deductions against future taxable gains. All loss carryforwards are due no earlier than 2028 or are unlimited in time.

#### Global minimum level of taxation

The majority of countries where Thule Group is established have introduced similar rules on minimum taxation. In Sweden, this has been implemented through Law No. SFS 2023:875 on supplementary tax. The law comprises an implementation of Council Directive (EU) 2022/2523, which in turn is based on the model rules on minimum taxation and related guidance such as the OECD/G20 Inclusive Framework (IF). Essentially, the rules on minimum taxation entail calculating the effective tax rate in each country where the group is established. An additional amount of tax (a "top-up tax") is collected if the effective tax rate is less than 15 percent, primarily through legislation in the low-tax country and secondly, in the absence of such local rules, in the country in which the parent company is resident. The rules apply for the first time for the income year 2024.

Thule Group has assessed the expected effect of these rules for the income year 2024. The assessment is that the rules on minimum taxation will have no material impact on Thule Group's tax expense for the income year 2024.

**Note 16****Earnings per share**

	2024	2023
<b>Earnings per share before dilution</b>		
Net income attributable to Parent Company shareholders, SEKm	1,122	1,099
Average number of shares outstanding, thousand	105,909	105,176
<b>Earnings per share before dilution, SEK</b>	<b>10.59</b>	<b>10.45</b>
<b>Earnings per share after dilution</b>		
Net income attributable to Parent Company shareholders, SEKm	1,122	1,099
Average number of shares outstanding, thousand	105,909	105,267
<b>Earnings per share after dilution, SEK</b>	<b>10.59</b>	<b>10.44</b>

**Earnings per share before dilution**

The calculation for earnings per share is based on net income attributable to the Parent Company shareholders and on a weighted average number of shares outstanding.

In thousands of shares	2024	2023
Total number of shares issued as of January 1	105,733	104,562
Impact of issues	176	614
	<b>105,909</b>	<b>105,176</b>

**Earnings per share after dilution**

The calculation for earnings per share after dilution is based on net income attributable to the Parent Company shareholders and on a weighted average number of shares outstanding.

In thousands of shares	2024	2023
Weighted average number of shares	105,909	105,176
Impact of warrants	—	91
	<b>105,909</b>	<b>105,267</b>

## Note 17

### Intangible assets

Group, SEKm	Goodwill	Brands	Customer relations	Intellectual property rights	Other intangible assets	Total
<b>Accumulated cost</b>						
<b>Opening balance, January 1, 2023</b>	<b>4,963</b>	<b>23</b>	<b>—</b>	<b>—</b>	<b>227</b>	<b>5,213</b>
Other investments	—	—	—	—	0	0
Exchange rate differences for the year	-106	0	—	—	-3	-109
<b>Closing balance, December 31, 2023</b>	<b>4,857</b>	<b>23</b>	<b>—</b>	<b>—</b>	<b>246</b>	<b>5,103</b>
<b>Opening balance, January 1, 2024</b>						
Other investments	—	—	—	—	0	0
Acquisitions	2,329	745	128	381	6	3,589
Divestments	—	—	—	—	-1	-1
Exchange rate differences for the year	230	-28	-5	-14	5	188
<b>Closing balance, December 31, 2024</b>	<b>7,417</b>	<b>739</b>	<b>123</b>	<b>367</b>	<b>233</b>	<b>8,879</b>
<b>Accumulated amortization and impairment</b>						
<b>Opening balance, January 1, 2023</b>	<b>0</b>	<b>0</b>	<b>0</b>	<b>0</b>	<b>-213</b>	<b>-213</b>
Divestments	—	—	—	—	0	0
Amortization for the year	—	—	—	—	-5	-5
Exchange rate differences for the year	—	—	—	—	3	3
<b>Closing balance, December 31, 2023</b>	<b>0</b>	<b>0</b>	<b>0</b>	<b>0</b>	<b>-216</b>	<b>-216</b>
<b>Opening balance, January 1, 2024</b>	<b>0</b>	<b>0</b>	<b>0</b>	<b>0</b>	<b>-216</b>	<b>-216</b>
Divestments	—	—	—	—	1	1
Amortization for the year	—	—	-1	-2	-5	-9
Exchange rate differences for the year	—	—	—	—	-4	-4
<b>Closing balance, December 31, 2024</b>	<b>0</b>	<b>0</b>	<b>-1</b>	<b>-2</b>	<b>-225</b>	<b>-228</b>
<b>Carrying amounts</b>						
As of January 1, 2023	4,963	23	—	—	14	4,999
<b>As of December 31, 2023</b>	<b>4,857</b>	<b>23</b>	<b>—</b>	<b>—</b>	<b>8</b>	<b>4,887</b>
As of January 1, 2024	4,857	23	—	—	8	4,887
<b>As of December 31, 2024</b>	<b>7,417</b>	<b>739</b>	<b>122</b>	<b>365</b>	<b>8</b>	<b>8,651</b>

#### Amortization and impairment are included in the following rows of the income statement

SEKm	2024	2023
Cost of goods sold	1	1
Selling expenses	5	2
Administrative expenses	3	3
<b>Total</b>	<b>9</b>	<b>5</b>

The Group does not have any internally generated intangible assets. The total development expenses for the year amounted to SEK 671m (629).

#### Impairment testing of goodwill and brands

Goodwill and brands are tested if there is any need for impairment as soon as such indications occur. Furthermore, an annual test is performed regardless of the occurrence of indications. Impairment testing is performed through estimating the recoverable amount and comparing it with the carrying amount. Regarding the recently acquired assets, they have not been tested for impairment as they were acquired in December 2024. A preliminary purchase price allocation is presented in Note 5 Business combinations.

#### Impairment testing 2024

In the impairment test, the cash-generating unit's estimated value-in-use constitutes the recoverable amount. The current weighted average cost of capital (WACC), estimated at 9.3 percent (8.3) after tax and 11.1 percent (9.9) before tax, is used in the present value calculation of the value-in-use. The requirement for return on equity is determined according to the Capital Asset Pricing Model and interest for debt/equity ratio reflects a market-based borrowing cost. Used leverage ratio has been set at 20 percent. The estimates that form the basis of calculating the value-in-use were based on budgets determined by company management for the coming year and on strategic plans established by the Board for the next three years. The cash flow for the subsequent years has been extrapolated, assuming an annual growth rate of 3 percent (3).

#### Important variables in forecasting cash flows

##### Growth rate

Thule Group's growth rate year 1–3 is based on sales volume growth. These assumptions are based on planned launches of new products, planned price increases, marketing investments and historical experience. The market growth used is expected to follow the general growth rate of each market.

##### Level of performance

Raw material costs for the larger categories were reviewed. Forecasted payroll expenses are based on expected inflation, a degree of real income growth, planned efficiency enhancements in the Group's production and impacts of planned recruiting. The forecast is also based on the effective handling of the Group's working capital and necessary replacement investments. The recoverable amount exceeds the carrying amount. On analysis of the impairment need for goodwill, the company performed a sensitivity analysis through a +2 percentage point adjustment of the discount rate and a -2 percentage point adjustment of sales growth. The variables were sensitivity tested in combination with each other, and the sensitivity analysis indicated no need for any impairment.

## Note 18

### Tangible assets

The Group's tangible assets comprise owned and leased assets:

SEKm	Note	2024	2023
Owned tangible assets		2,112	1,907
Right-of-use assets	22	227	215
		<b>2,339</b>	<b>2,122</b>

Group, SEKm	Buildings and land	Plant and machinery	Equipment, tools, fixtures and fittings	Construction in progress	Total
<b>Accumulated cost</b>					
<b>Opening balance, January 1, 2023</b>	<b>1,246</b>	<b>1,052</b>	<b>276</b>	<b>198</b>	<b>2,773</b>
Other investments	21	21	18	210	269
Divestments and scrapping	-1	-52	-13	0	-66
From in progress	27	215	8	-251	0
Exchange rate differences for the year	14	5	-4	9	24
<b>Closing balance, December 31, 2023</b>	<b>1,306</b>	<b>1,242</b>	<b>285</b>	<b>167</b>	<b>3,000</b>
<b>Opening balance, January 1, 2024</b>	<b>1,306</b>	<b>1,242</b>	<b>285</b>	<b>167</b>	<b>3,000</b>
Other investments	12	21	16	238	288
Acquisitions	5	31	8	—	44
Divestments and scrapping	-4	-18	-15	0	-36
From in progress	29	168	62	-258	0
Other changes/reclassifications	-1	—	0	-1	-1
Exchange rate differences for the year	46	49	15	6	116
<b>Closing balance, December 31, 2024</b>	<b>1,393</b>	<b>1,493</b>	<b>372</b>	<b>152</b>	<b>3,410</b>
<b>Accumulated depreciation and impairment</b>					
<b>Opening balance, January 1, 2023</b>	<b>-328</b>	<b>-494</b>	<b>-172</b>	<b>0</b>	<b>-995</b>
Divestments and scrapping	1	46	13	—	60
Depreciation for the year	-41	-100	-23	—	-163
Exchange rate differences for the year	2	0	3	—	5
<b>Closing balance, December 31, 2023</b>	<b>-365</b>	<b>-548</b>	<b>-179</b>	<b>0</b>	<b>-1,093</b>
<b>Opening balance, January 1, 2024</b>	<b>-365</b>	<b>-548</b>	<b>-179</b>	<b>0</b>	<b>-1,093</b>
Divestments and scrapping	4	15	13	—	33
Depreciation for the year	-43	-116	-31	—	-189
Other changes/reclassifications	1	—	0	—	1
Exchange rate differences for the year	-18	-22	-10	—	-50
<b>Closing balance, December 31, 2024</b>	<b>-421</b>	<b>-670</b>	<b>-206</b>	<b>0</b>	<b>-1,298</b>
<b>Carrying amounts</b>					
As of January 1, 2023	918	558	105	198	1,778
<b>As of December 31, 2023</b>	<b>941</b>	<b>693</b>	<b>106</b>	<b>167</b>	<b>1,907</b>
As of January 1, 2024	941	693	106	167	1,907
<b>As of December 31, 2024</b>	<b>972</b>	<b>823</b>	<b>166</b>	<b>152</b>	<b>2,112</b>

## Note 19 Inventories

Group, SEKm	Dec 31, 2024	Dec 31, 2023
Raw materials and consumables	495	587
Products in progress	216	259
Finished goods and goods for resale	1,444	1,453
<b>Total</b>	<b>2,155</b>	<b>2,300</b>

Change in recognized inventory obsolescence	2024	2023
On January 1	334	225
Provision for obsolescence	128	232
Impairment of inventories	-51	-44
Reversal of previous years' reserves	-127	-75
Currency effect	17	-4
<b>On December 31</b>	<b>301</b>	<b>334</b>

## Note 20 Accounts receivable

Thule Group applies the simplified approach to measuring expected credit losses, which uses a lifetime expected loss allowance for accounts receivable. The approach also entails an assessment of expected credit losses (ECLs) as opposed to events incurred. When assessment of a customer on an individual basis is not reasonable, an assessment is made using ECLs based on payment history and age analysis of accounts receivables past due.

Based on the above, the loss allowance for accounts receivable as per December 31, 2024 follows in the table below.

### Age analysis of provision for doubtful receivables

Group, SEKm	Dec 31, 2024	Dec 31, 2023
Not past due	-2	-1
1–30 days past due	-1	-1
31–60 days past due	-3	-2
More than 60 days past due	-22	-16
<b>Total</b>	<b>-28</b>	<b>-21</b>

Group, SEKm	Dec 31, 2024	Dec 31, 2023
Accounts receivable, gross	792	727
Less provision for doubtful receivables	-28	-21
<b>Accounts receivable, net</b>	<b>764</b>	<b>706</b>

There was no significant concentration of credit exposure on the balance sheet date. The majority of the Group's customers primarily comprise medium-sized customers.

Age analysis of accounts receivable, SEKm	Dec 31, 2024	Dec 31, 2023
Not past due	678	605
1–30 days past due	80	67
31–60 days past due	9	19
More than 60 days past due	26	35
Less provision for doubtful receivables	-28	-21
<b>Total</b>	<b>764</b>	<b>706</b>

Fair value of accounts receivable agrees with the carrying amount. The credit quality of receivables with no provision is considered to be high.

Changes in the provisions for doubtful receivables are as follows

SEKm	2024	2023
On January 1	-21	-60
Provision for doubtful receivables	-19	-12
Receivables written off during the year as uncollectible	3	3
Reversal of previous years' reserves	9	48
Currency effect	-1	1
<b>On December 31</b>	<b>-28</b>	<b>-21</b>

## Note 21 Specific disclosures regarding equity

Thousand shares	2024	2023
Issued January 1	105,733	104,562
<b>Issued December 31 – paid</b>	<b>107,838</b>	<b>105,733</b>

The shares of Thule Group AB are listed on the Nasdaq Stockholm Large Cap list. The Group did not buy back or hold any treasury shares during the fiscal year. The number of shares approved, issued and fully paid as per December 31, 2024 was 107,838,162. The company has only one class of share. At General Meetings of shareholders, each share carries one vote and each shareholder is entitled to vote for the full number of shares such a shareholder holds in the company. All shares carry equal rights to the company's assets and profits. The quotient value (nominal value) of the share is SEK 0.01118 per share.

### Capital management

Under the Board's policy, the Group's financial target is to maintain a financial position that is conducive to maintaining investor, creditor and market confidence and to constitute a stable foundation for continued development of business operations.

The Board seeks to maintain a balance between the higher returns, that may be possible with higher levels of borrowings, and the advantages and security offered by a sound capital structure. The key metric that the company's management and external stakeholders mainly assess with respect to capital structure is the net debt to EBITDA ratio. Thule Group aims to maintain an effective long-term capital structure, defined as the net debt to EBITDA ratio. This key metric is monitored on a regular basis via the internal reporting to management and the Board. Net debt in relation to pro forma EBITDA totaled 1.8 (1.1) as per December 31, 2024.

### Group

#### Translation reserve

The translation reserve includes all exchange rate differences arising on the translation of the financial statements from foreign operations that have prepared their financial statements in a different currency to the currency in which the consolidated financial statements are presented. The Parent Company and Group present their financial statements in Swedish kronor (SEK). Furthermore, the translation reserve comprises exchange rate differences arising from the revaluation of liabilities that were recognized as hedging instruments of a net investment in a foreign business.

#### Hedge reserve

The hedge reserve includes the effective portion of the accumulated net change in fair value of a cash flow hedging instrument attributable to hedge transactions that have not yet occurred.

### Parent Company

#### Restricted reserves

Restricted reserves may not be reduced through dividends. Aside from the share capital, the Parent Company has no restricted reserves.

#### Non-restricted equity

The following reserves, together with net income, comprise non-restricted equity – the amount that is available for shareholder dividends.

#### Share premium reserve

When shares are issued at a premium, meaning that a higher amount than the quotient value is paid for the share, an amount corresponding to the surplus of the quotient value of the share is recognized in the share premium reserve.

#### Profit brought forward

Profit brought forward comprises profit brought forward from the preceding year and earnings after deductions for any dividends paid during the year.

## Note 22

### Leases

The Group's tangible assets comprise owned and leased assets:

SEKm	Note	2024	2023
Owned tangible assets	18	2,112	1,907
Right-of-use assets		227	215
		<b>2,339</b>	<b>2,122</b>

Group, SEKm	Properties	Plant and machinery	Equipment, tools, fixtures and fittings	Total
<b>Accumulated right-of-use assets</b>				
<b>Opening balance, January 1, 2023</b>	<b>321</b>	<b>0</b>	<b>127</b>	<b>449</b>
Right-of-use assets acquired for the year	37	0	45	82
Right-of-use assets divested for the year	-3	0	-34	-38
Exchange rate differences for the year	-9	0	1	-8
<b>Closing balance, December 31, 2023</b>	<b>346</b>	<b>0</b>	<b>140</b>	<b>486</b>
<b>Opening balance, January 1, 2024</b>	<b>346</b>	<b>0</b>	<b>140</b>	<b>486</b>
Right-of-use assets acquired for the year	35	2	39	75
Acquisitions	13	—	—	13
Right-of-use assets divested for the year	-36	-1	-42	-79
Exchange rate differences for the year	18	0	4	21
<b>Closing balance, December 31, 2024</b>	<b>375</b>	<b>1</b>	<b>140</b>	<b>516</b>

Group, SEKm	Properties	Plant and machinery	Equipment, tools, fixtures and fittings	Total
<b>Accumulated depreciation and impairment</b>				
<b>Opening balance, January 1, 2023</b>	<b>-154</b>	<b>0</b>	<b>-67</b>	<b>-221</b>
Right-of-use assets acquired/divested for the year, net	3	0	31	35
Depreciation for the year	-51	0	-39	-90
Exchange rate differences for the year	6	0	-1	5
<b>Closing balance, December 31, 2023</b>	<b>-195</b>	<b>0</b>	<b>-75</b>	<b>-271</b>
<b>Opening balance, January 1, 2024</b>	<b>-195</b>	<b>0</b>	<b>-75</b>	<b>-271</b>
Right-of-use assets acquired/divested for the year, net	36	0	42	78
Depreciation for the year	-42	0	-42	-84
Exchange rate differences for the year	-9	0	-2	-11
<b>Closing balance, December 31, 2024</b>	<b>-211</b>	<b>0</b>	<b>-78</b>	<b>-289</b>
As of January 1, 2023	167	0	61	228
<b>As of December 31, 2023</b>	<b>150</b>	<b>0</b>	<b>64</b>	<b>215</b>
As of January 1, 2024	150	0	64	215
<b>As of December 31, 2024</b>	<b>164</b>	<b>1</b>	<b>62</b>	<b>227</b>

The Group leases several types of assets, primarily premises and vehicles, but assets also include machinery and IT equipment to a limited extent. No leases include covenants or other limitations over and above collateral in the leased asset.

#### Lease liabilities

Group, SEKm	Dec 31, 2024	Dec 31, 2023
Short-term	74	99
Long-term	150	128
<b>Lease liabilities in the balance sheet</b>	<b>224</b>	<b>227</b>

Refer to Note 4 Financial risk management for the maturity analysis of lease liabilities.

#### Amounts recognized through profit or loss

Group, SEKm	2024	2023
Depreciation and impairment of right-of-use assets	-84	-90
Interest on lease liabilities	-6	-5
Variable lease payments not included in the measurement of the lease liability	-7	-8
Costs for short-term leases	0	-1
Costs for low-value leases, not low-value short-term leases	-1	-1

The total cash flow for leases in 2024 was SEK 109m (103).

#### Property leases

The Group leases buildings and land for its offices, warehouses and factories. The leases extend for periods of 1–18 years for offices, 1–7 years for warehouses and 1–5 years for factories.

Some leases include lease payments based on changes in a local price index. Accordingly, the Group is to some extent exposed to possible future increases in variable lease payments based on indices or interest that are not included in the lease liability until they enter force. When index- or interest-linked adjustments of lease payments enter force, the lease liability is remeasured and adjusted against the right-of-use asset. Some leases also require the Group to pay fees pertaining to property taxes levied on the lessor. These fees are set each year.

#### Extension and termination options

Some leases contain extension and termination options that the Group could choose to exercise or allow to expire. When the Group makes an assessment that sufficient financial inducement exists to extend a contract, an assumption is made from the start of the contract that it will be extended if possible. Extension options can only be used by the Group, not by the lessor. It is assumed that the extension option will not be used for contracts where the Group's assessment at the start of the contract was that the extension option held no significant financial incentives. The Group re-examines whether it is reasonably certain that an extension option will be exercised if there is an important event or significant changes in circumstances that are within the Group's control.

The Group's office leases extend for periods of 1–18 years. The majority of these contracts offer extension options, whereby the Group must notify the lessor that the Group intends to exercise an extension option at least 1 year before the contract expires. Other contracts are subject to automatic renewal unless the Group uses a termination option within a stated period prior to the end of the contract. This period varies among the contracts between 3, 6, 9 or 12 months.

The Group's warehouse leases mainly extend for periods of 1–7 years. Following the first period, most contracts can be extended for one or more periods of 1–3 years. Some of the contracts are automatically renewed unless terminated 1–9 months prior to the end date of the contract, while in other contracts the Group must actively notify the lessor of the choice to exercise an extension option no later than 1 year before the end date of the contract.

For offices and warehouses, in the majority of cases, the Group considers that it is not reasonably certain that the contracts will be renewed beyond the first period. In other words, the lease term is usually assessed as one period and is only extended if or when this assessment

changes. The recognized lease liability for these contracts amounted to SEK 80m (56) and SEK 68m (84), respectively.

The Group also has contracts for factory leases. These extend for periods of 1–5 years, with options for the Group to extend for further periods. For the majority of factory leases, the Group's assessment is that it is reasonably certain that further periods will be used. The recognized lease liability for these contracts amounted to SEK 13m (23).

Over the year, lease liabilities decreased SEK 15m as a result of utilizing options that were not previously included in the lease liability. Significant changes could arise in the future if the lease term of the Group's material property leases should be subjected to retesting.

#### Other leases

The Group also leases plant and machinery as well as other technical installations and equipment, tools, fixtures and fittings. These categories mainly comprise vehicles, machinery and IT equipment with respective lease periods of 1–6, 1–5 and 1–8 years. While residual value guarantees and extension options arise, these are of limited and non-material scope.

Payments for short-term leases of equipment and vehicles, and all low-value leases, are recognized on a straight-line basis as an expense in profit or loss. Short-term leases are leases with a lease term of 12 months or less. Low-value leases include IT equipment, small forklifts and other small pieces of equipment.

## Note 23 Interest-bearing liabilities

Long-term interest-bearing liabilities, SEKm	Group		Parent Company	
	Dec 31, 2024	Dec 31, 2023	Dec 31, 2024	Dec 31, 2023
Long-term liabilities to credit institutions	4,143	1,903	4,143	1,903
Leases	150	128	—	—
Long-term derivative liabilities	7	7	—	—
<b>Total</b>	<b>4,301</b>	<b>2,038</b>	<b>4,143</b>	<b>1,903</b>

Short-term interest-bearing liabilities, SEKm	Group		Parent Company	
	Dec 31, 2024	Dec 31, 2023	Dec 31, 2024	Dec 31, 2023
Short-term liabilities to credit institutions	1	—	—	—
Overdraft facilities	0	3	—	—
Leases	74	99	—	—
Short-term derivative liabilities	2	34	—	—
<b>Total</b>	<b>77</b>	<b>136</b>	<b>0</b>	<b>0</b>

Term structure of liabilities, SEKm	Group		Parent Company	
	Dec 31, 2024	Dec 31, 2023	Dec 31, 2024	Dec 31, 2023
Overdraft facilities	0	3	—	—
1 year	77	133	—	—
2–3 years	2,562	1,978	2,491	1,903
4–5 years	1,688	11	1,652	—
More than 5 years	50	49	—	—
<b>Total</b>	<b>4,377</b>	<b>2,174</b>	<b>4,143</b>	<b>1,903</b>

## Note 24 Accrued expenses and deferred income

SEKm	Group		Parent Company	
	Dec 31, 2024	Dec 31, 2023	Dec 31, 2024	Dec 31, 2023
Employee-related expenses	245	224	25	26
Bonuses to customers	122	115	—	—
Other items	258	174	72	5
<b>Total</b>	<b>625</b>	<b>513</b>	<b>97</b>	<b>31</b>

## Note 25 Provisions

SEKm	Group		Parent Company	
	Dec 31, 2024	Dec 31, 2023	Dec 31, 2024	Dec 31, 2023
Restructuring expenses	0	0	—	—
Guarantee commitments	65	42	—	—
Other provisions	13	6	—	—
<b>Total</b>	<b>78</b>	<b>49</b>	<b>—</b>	<b>—</b>

SEKm	Restructuring expenses	Other provisions	Guarantee commitments
Carrying amount at beginning of year	0	6	42
New provisions	—	6	14
Amounts utilized during the period	—	—	-11
Acquisitions	—	—	20
Currency effect	—	0	0
<b>Carrying amount at end of period</b>	<b>0</b>	<b>13</b>	<b>65</b>

## Note 26

### Cash flow statement

SEKm	Group		Parent Company	
	2024	2023	2024	2023
Interest paid net	-122	-95	-17	-7
<b>Adjustments for items not included in cash flow</b>				
Anticipated dividends from subsidiaries	—	—	-550	-600
Depreciation/amortization and impairment of assets	283	293	—	—
Capital gain/loss from divestment of operations/shares/equipment	2	6	—	—
Unrealized and other financial items	-1	5	—	—
<b>Total</b>	<b>282</b>	<b>303</b>	<b>-550</b>	<b>-600</b>

#### Reconciliation of liabilities attributable to financing activity

SEKm	Opening balance, Jan 1, 2024	Cash flows	Concluded agreements entered into, net	Financial costs	Acquisitions	Exchange rate differences	Closing balance Dec 31, 2024
Liabilities to credit institutions	1,905	2,225	—	—	—	35	4,165
Capitalized financing costs	-2	-24	—	5	—	—	-21
Overdraft facilities	3	-3	—	—	—	—	0
Leases	227	-101	74	—	13	11	224
Derivative liabilities	41	—	—	—	—	-32	10
<b>Total according to balance sheet</b>	<b>2,174</b>	<b>2,097</b>	<b>74</b>	<b>5</b>	<b>13</b>	<b>14</b>	<b>4,377</b>

#### Acquisition of subsidiaries and other business units

SEKm	2024	2023
<b>Acquisition of subsidiaries and other business units</b>		
Acquired assets and liabilities		
Intangible assets	3,589	—
Tangible assets	57	—
Inventories	270	—
Short-term receivables	116	—
Cash and cash equivalents	51	—
<b>Total assets</b>	<b>4,083</b>	<b>—</b>
Short-term liabilities	877	—
<b>Total liabilities</b>	<b>877</b>	<b>—</b>
Purchase consideration	3,206	—
Non-cash items	-761	—
Refinancing of liabilities	443	—
Less: Cash and cash equivalents	-51	—
<b>Impact on cash and cash equivalents</b>	<b>2,837</b>	<b>—</b>

#### Cash and cash equivalents

SEKm	2024	Group 2023	2024	Parent Company 2023
The following sub-components are included in cash and cash equivalents:				
Cash and bank balances	131	92	—	—
Short-term investments, equal to cash and cash equivalents	274	2	—	—
<b>Total according to balance sheet</b>	<b>405</b>	<b>94</b>	<b>0</b>	<b>0</b>

## Note 27 Appropriations

Parent Company, SEKm	2024	2023
Group contribution received	90	120
<b>Total</b>	<b>90</b>	<b>120</b>

## Note 28 Participations in subsidiaries

Parent Company, SEKm	Dec 31, 2024	Dec 31, 2023
Opening cost	1,000	1,000
Shareholder contributions	757	—
Closing accrued cost	1,757	1,000
<b>Closing carrying amount of direct holdings of participations in subsidiaries</b>	<b>1,757</b>	<b>1,000</b>

Name	Corp. Reg. No.	Registered office	Share of equity, %
Thule AB	556770-6329	Malmö	100
Thule Holding AB	556662-7138	Malmö	100
Thule Holdco Pty Ltd		South Yarra	100
Thule Bidco Pty Ltd		South Yarra	100
Key Topco Pty Ltd		South Yarra	100
Key Holdco Pty Ltd		South Yarra	100
Key Midco Pty Ltd		South Yarra	100
Key Bidco Pty Ltd		South Yarra	100
Quad Lock Pty Ltd		South Yarra	100
Annex Products Pty Ltd		South Yarra	100
Thule Towing Systems AB	556259-0298	Malmö	100
Thule NV		Menen	100
Thule Organization Solutions Asia Pacific Ltd.		Hong Kong	100
Thule Trading (Beijing) Co. Ltd		Beijing	100
Thule Organization Solutions S.A.		Louvain-La-Neuve	100
Thule Organization Solutions S.A.R.L		Rosny-Sous-Bois	100
Thule Organization Solutions BV		Utrecht	100
Thule Finans AB	556043-6858	Malmö	100
Thule Sp.zo.o.		Huta	100
Thule Japan KK		Tokyo	100
Thule S.r.o		Prague	100
Thule Sweden AB	556076-3970	Gnosjö	100
Thule Brasil Comercial e importadora Ltda.		São Paulo	100
Thule IP AB	556578-1282	Malmö	100
Thule Merchandizing AB	556849-4016	Malmö	100
Thule Brasil Distribuidora Ltda		São Paulo	100
Thule Sport Rack Beheer B.V.		Staphorst	100
Thule Canada Holding LLC		Wilmington, Delaware	100
Thule Canada Inc.		Granby	100
Thule Holding ApS		Copenhagen	100
Brink Nordisk Holdings ApS		Copenhagen	100
Thule Inc.		Seymour	100
Thule Holding Ltd.		Haverhill	100
Thule Outdoor Ltd.		Haverhill	100
Thule Deutschland Holding AB	556662-7419	Malmö	100
Thule GmbH		Neumarkt	100
good goods tegernsee Gmbh		Neumarkt	100

## Note 29

### Pledged assets

There are no pledged assets in the Group.

## Note 30

### Contingent liabilities

Group, SEKm	Dec 31, 2024	Dec 31, 2023
Bank guarantees	29	24
Pension liability, PRI	3	3
Other guarantee commitments	40	33
<b>Total contingent liabilities</b>	<b>72</b>	<b>60</b>

## Note 31

### Events after the balance sheet date

No significant events have occurred after the balance sheet date.

## Note 32

### Related-party transactions

All of the Group companies presented in Note 28 are considered to be related parties. Transactions take place between Thule Group companies concerning deliveries of goods and services, and the provision of financial and intangible services. Market terms and pricing are applied to all transactions. All intra-Group transactions are eliminated. The Parent Company's transactions with subsidiaries comprise the transactions presented below.

Parent Company

Receivables from and liabilities to subsidiaries, SEKm	Dec 31, 2024	Dec 31, 2023
Long-term interest-bearing receivables	5,759	3,499
Short-term interest-bearing receivables	745	721
Long-term interest-bearing liabilities	—	—
Short-term interest-bearing liabilities	-1,928	-1,546
<b>Total</b>	<b>4,576</b>	<b>2,673</b>

Thule Group AB issued warrants as part of an incentive program for management. Warrants have been issued to and subscribed for by Thule Group AB's subsidiary, Thule AB.

For information regarding remuneration and benefits paid to executive management and the Board, refer to notes 11 and 12.

# Assurance

The income statements and balance sheets will be presented to the Annual General Meeting on April 29, 2025 for adoption.

The Board of Directors and the CEO & President affirm that this Annual Report was prepared in accordance with generally accepted accounting policies in Sweden and that the consolidated financial statements were prepared in accordance with the international accounting standards referred to in Regulation (EC) No 1606/2002 of the European Parliament and the Council issued on July 19, 2002 on the application of international accounting standards. The Annual Report and consolidated financial statements provide a true and fair view of the Parent Company's and the Group's financial position and earnings. The Board of Directors' Report provides a true and fair overview of the Parent Company's and the Group's operations, financial position and earnings, and describes the significant risks and uncertainties to which the Parent Company and the companies included in the Group are exposed.

Malmö, April 4, 2025

Hans Eckerström  
Chairman of the Board

Sandra Finér  
Board member

Paul Gustavsson  
Board member

Anders Jensen  
Board member

Sarah McPhee  
Board member

Johan Westman  
Board member

Helene Willberg  
Board member

Mattias Ankarberg  
CEO & President

Our auditor's report was submitted on  
April 7, 2025

Öhrlings PricewaterhouseCoopers AB

Sofia Götmar Blomstedt  
Authorized Public Accountant  
Auditor in Charge

Neda Feher  
Authorized Public Accountant

# Auditor's report

Unofficial translation

## To the general meeting of the shareholders of Thule Group AB (publ), corporate identity number 556770-6311

## Report on the annual accounts and consolidated accounts

### OPINIONS

We have audited the annual accounts and consolidated accounts of Thule Group AB (publ) for the year 2024 except for the corporate governance statement on pages 84–89. The annual accounts and consolidated accounts of the company are included on pages 72–121 in this document. In our opinion, the annual accounts have been prepared in accordance with the Annual Accounts Act and present fairly, in all material respects, the financial position of parent company and the group as of 31 December 2024 and its financial performance and cash flow for the year then ended in accordance with the Annual Accounts Act. The consolidated accounts have been prepared in accordance with the Annual Accounts Act and present fairly, in all material respects, the financial position of the group as of 31 December 2024 and their financial performance and cash flow for the year then ended in accordance with IFRS Accounting Standards as adopted by the EU, and the Annual Accounts Act. Our opinions do not cover the corporate governance statement on pages 84–89. The statutory administration report is consistent with the other parts of the annual accounts and consolidated accounts.

We therefore recommend that the general meeting of shareholders adopts the income statement and balance sheet for the parent company and the group.

Our opinions in this report on the annual accounts and consolidated accounts are consistent with the content of the additional report that has been submitted to the parent company's audit & sustainability committee in accordance with the Audit Regulation (537/2014) Article 11.

### BASIS FOR OPINIONS

We conducted our audit in accordance with International Standards on Auditing (ISA) and generally accepted auditing standards in Sweden. Our responsibilities under those standards are further described in the Auditor's Responsibilities section. We are independent of the parent company and the group in accordance with professional ethics for accountants in Sweden and have otherwise fulfilled our ethical responsibilities in accordance with these requirements. This includes that, based on the best of our knowledge and belief, no prohibited services referred to in the Audit Regulation (537/2014) Article 5.1 have been provided to the audited company or, where applicable, its parent company or its controlled companies within the EU.

We believe that the audit evidence we have obtained is sufficient and appropriate to provide a basis for our opinions.

## Our audit approach

### AUDIT SCOPE

We designed our audit by determining materiality and assessing the risks of material misstatement in the consolidated financial statements. In particular, we considered where management made subjective judgments; for example, in respect of significant accounting estimates that involved making assumptions and considering future events that are inherently uncertain. As in all of our audits, we also addressed the risk of management override of internal controls, including among other matters consideration of whether there was evidence of bias that represented a risk of material misstatement due to fraud.

We tailored the scope of our audit in order to perform sufficient work to enable us to provide an opinion on the consolidated financial statements as a whole, taking into account the structure of the Group, the accounting processes and controls, and the industry in which the group operates.

Based on this, we determined which companies within the Group were deemed to be significant and determined audit activities to be performed on these companies. In total, 9 companies have been deemed to be significant. Entities that have not been deemed as significant, have been reviewed by the Group audit team. The majority of the entities not included in the Group audit are subject to statutory audits in their respective countries. During the year, the Group audit team had digital and physical meetings with some of the significant entities in

the Group with the aim of gaining understanding of the operations in these countries, compliance of the Group's internal control framework, including the process for financial reporting. The Group audit team has, in addition and amongst other things, executed an audit of the parent company, the consolidation, the annual financial statements and significant assumptions and estimates. Based on the performed audit activities mentioned above, we deem that we have obtained sufficient audit evidence to provide an opinion on the financial reports as a whole.

### MATERIALITY

The scope of our audit was influenced by our application of materiality. An audit is designed to obtain reasonable assurance whether the financial statements are free from material misstatement. Misstatements may arise due to fraud or error. They are considered material if individually or in aggregate, they could reasonably be expected to influence the economic decisions of users taken on the basis of the consolidated financial statements.

Based on our professional judgment, we determined certain quantitative thresholds for materiality, including the overall group materiality for the consolidated financial statements as a whole as set out in the table below. These, together with qualitative considerations, helped us to determine the scope of our audit and the nature, timing and extent of our audit procedures and to evaluate the effect of misstatements, both individually and in aggregate on the financial statements as a whole.

## Key audit matters

Key audit matters of the audit are those matters that, in our professional judgment, were of most significance in our audit of the annual accounts and consolidated accounts of the current period. These matters were addressed in the context of our audit

of, and in forming our opinion thereon, the annual accounts and consolidated accounts as a whole, but we do not provide a separate opinion on these matters.

## Other Information than the annual accounts and consolidated accounts

This document also contains other information than the annual accounts and consolidated accounts and is found on pages 1–71 and 125–142. The other information also consists of the Remuneration report which we have received before the date of this auditor's report and which has been published on the company's website before the publication of this document. This information, in addition to the sustainability report and our statement regarding this report, do not constitute a part of the annual report. The Board of Directors and the Managing Director are responsible for this other information.

Our opinion on the annual accounts and consolidated accounts does not cover this other information and we do not express any form of assurance conclusion regarding this other information.

In connection with our audit of the annual accounts and consolidated accounts, our responsibility is to read the information identified above and consider whether the information is materially inconsistent with the annual accounts and consolidated accounts. In this procedure we also take into account our knowledge otherwise obtained in the audit and assess whether the information otherwise appears to be materially misstated.

If we, based on the work performed concerning this information, conclude that there is a material misstatement of this other information, we are required to report that fact. We have nothing to report in this regard.

### RESPONSIBILITIES OF THE BOARD OF DIRECTOR'S AND THE MANAGING DIRECTOR

The Board of Directors and the Managing Director are responsible for the preparation of the annual accounts and consolidated accounts and that they give a fair presentation in accordance with the Annual Accounts Act and, concerning the consolidated accounts, in accordance with IFRS Accounting Standards as adopted by the EU. The Board of Directors and the Managing Director are

also responsible for such internal control as they determine is necessary to enable the preparation of annual accounts and consolidated accounts that are free from material misstatement, whether due to fraud or error.

In preparing the annual accounts and consolidated accounts, The Board of Directors and the Managing Director are responsible for the assessment of the company's and the group's ability to continue as a going concern. They disclose, as applicable, matters related to going concern and using the going concern basis of accounting. The going concern basis of accounting is however not applied if the Board of Directors and the Managing Director intend to liquidate the company, to cease operations, or has no realistic alternative but to do so.

The Audit & Sustainability Committee shall, without prejudice to the Board of Director's responsibilities and tasks in general, among other things oversee the company's financial reporting process.

### AUDITOR'S RESPONSIBILITY

Our objectives are to obtain reasonable assurance about whether the annual accounts and consolidated accounts as a whole are free from material misstatement, whether due to fraud or error, and to issue an auditor's report that includes our opinions. Reasonable assurance is a high level of assurance, but is not a guarantee that an audit conducted in accordance with ISAs and generally accepted auditing standards in Sweden will always detect a material misstatement when it exists. Misstatements can arise from fraud or error and are considered material if, individually or in the aggregate, they could reasonably be expected to influence the economic decisions of users taken on the basis of these annual accounts and consolidated accounts.

A further description of our responsibility for the audit of the annual accounts and consolidated accounts is available on Revisorsinspektionen's website: [www.revisorsinspektionen.se/revisornsansvar](http://www.revisorsinspektionen.se/revisornsansvar). This description is part of the auditor's report.

## Report on other legal and regulatory requirements

### The auditor's examination of the administration of the company and the proposed appropriations of the company's profit or loss

#### OPINIONS

In addition to our audit of the annual accounts and consolidated accounts, we have also audited the administration of the Board of Director's and the Managing Director of Thule Group AB (publ) for the year 2024 and the proposed appropriations of the company's profit or loss.

We recommend to the general meeting of shareholders that the profit be appropriated in accordance with the proposal in the statutory administration report and that the members of the Board of Director's and the Managing Director be discharged from liability for the financial year.

#### BASIS FOR OPINIONS

We conducted the audit in accordance with generally accepted auditing standards in Sweden. Our responsibilities under those standards are further described in the Auditor's Responsibilities section. We are independent of the parent company and the group in accordance with professional ethics for accountants in Sweden and have otherwise fulfilled our ethical responsibilities in accordance with these requirements. We believe that the audit evidence we have obtained is sufficient and appropriate to provide a basis for our opinions.

### RESPONSIBILITIES OF THE BOARD OF DIRECTOR'S AND THE MANAGING DIRECTOR

The Board of Directors is responsible for the proposal for appropriations of the company's profit or loss. At the proposal of a dividend, this includes an assessment of whether the dividend is justifiable considering the requirements which the company's and the group's type of operations, size and risks

KEY AUDIT MATTER	HOW OUR AUDIT ADDRESSED THE KEY AUDIT MATTER
<p><b>Valuation of Goodwill and Intangible Assets with Indefinite Useful Lives</b></p> <p>Goodwill and intangible assets with indefinite useful lives (trademarks) constitute a significant part of Thule Group's balance sheet and amounted to SEK 8,156 million as of December 31, 2024.</p> <p>In December 2024, the acquisition of Quad Lock was completed. A preliminary purchase price allocation has been prepared and is presented in note 5. Assets with an indefinite useful life have been identified in trademarks and goodwill. Management has made significant estimates and judgments in connection with the purchase price allocation. The group's principles for business acquisitions are described in notes 1 and 2, and disclosures about the acquisition are provided in note 5.</p> <p>The reported value of goodwill, excluding the recently acquired values, has been subject to an impairment test that involves both complexity and significant elements of judgment. The impairment test is based on a high degree of estimates and assumptions about future cash flows. In note 1, section Impairments and note 17 outlines how the group has made its assessment, as well as an explanation of key assumptions regarding terminal growth rate, cost of capital (WACC), and sensitivity analyses.</p>	<p>Audit procedures over acquired assets during 2024 include, among other things:</p> <ul style="list-style-type: none"> <li>• We have reviewed the company's documentation over the acquisition and assessed management's assumptions in estimating the fair value of acquired identifiable assets and assumed liabilities.</li> <li>• With support from PwC's internal valuation specialists, we have examined the application of the calculation models used by management in estimating the fair value of acquired identifiable assets and assumed liabilities.</li> <li>• We have also assessed the accuracy of the disclosures presented in the annual report.</li> </ul> <p>Audit procedures over historical goodwill (from acquisitions made prior to 2024) include, among other things:</p> <ul style="list-style-type: none"> <li>• We have assessed the calculation model used by the company in its impairment test of goodwill.</li> <li>• We have reconciled and reviewed key assumptions against the company's budget and strategic plan.</li> <li>• We have followed up on how well the previous year's assumptions have been achieved.</li> <li>• We have tested the sensitivity of the key assumptions to assess the risk of an impairment.</li> <li>• We have also assessed the accuracy of the disclosures presented in the annual report.</li> </ul>

place on the size of the parent company's and the group' equity, consolidation requirements, liquidity and position in general.

The Board of Directors is responsible for the company's organization and the administration of the company's affairs. This includes among other things continuous assessment of the company's and the group's financial situation and ensuring that the company's organization is designed so that the accounting, management of assets and the company's financial affairs otherwise are controlled in a reassuring manner. The Managing Director shall manage the ongoing administration according to the Board of Directors' guidelines and instructions and among other matters take measures that are necessary to fulfill the company's accounting in accordance with law and handle the management of assets in a reassuring manner.

#### AUDITOR'S RESPONSIBILITY

Our objective concerning the audit of the administration, and thereby our opinion about discharge from liability, is to obtain audit evidence to assess with a reasonable degree of assurance whether any member of the Board of Directors or the Managing Director in any material respect:

- has undertaken any action or been guilty of any omission which can give rise to liability to the company, or
- in any other way has acted in contravention of the Companies Act, the Annual Accounts Act or the Articles of Association.

Our objective concerning the audit of the proposed appropriations of the company's profit or loss, and thereby our opinion about this, is to assess with reasonable degree of assurance whether the proposal is in accordance with the Companies Act.

Reasonable assurance is a high level of assurance, but is not a guarantee that an audit conducted in accordance with generally accepted auditing standards in Sweden will always detect actions or omissions that can give rise to liability to the company, or that the proposed

appropriations of the company's profit or loss are not in accordance with the Companies Act.

A further description of our responsibility for the audit of the administration is available on Revisorsinspektionen's website: [www.revisorsinspektionen.se/revisornsansvar](http://www.revisorsinspektionen.se/revisornsansvar). This description is part of the auditor's report.

### The auditor's examination of the Esef report

#### OPINION

In addition to our audit of the annual accounts and consolidated accounts, we have also examined that the Board of Directors and the Managing Director have prepared the annual accounts and consolidated accounts in a format that enables uniform electronic reporting (the Esef report) pursuant to Chapter 16, Section 4(a) of the Swedish Securities Market Act (2007:528) for Thule Group AB (publ) for the financial year 2024.

Our examination and our opinion relate only to the statutory requirements.

In our opinion, the Esef report has been prepared in a format that, in all material respects, enables uniform electronic reporting.

#### BASIS FOR OPINION

We have performed the examination in accordance with FAR's recommendation RevR 18 Examination of the Esef report. Our responsibility under this recommendation is described in more detail in the Auditors' responsibility section. We are independent of Thule Group AB (publ) in accordance with professional ethics for accountants in Sweden and have otherwise fulfilled our ethical responsibilities in accordance with these requirements.

We believe that the evidence we have obtained is sufficient and appropriate to provide a basis for our opinion.

#### RESPONSIBILITIES OF THE BOARD OF DIRECTOR'S AND THE MANAGING DIRECTOR

The Board of Directors and the Managing Director are responsible for the preparation of Esef report in accordance with the Chapter 16, Section 4(a) of the Swedish Securities Market Act (2007:528), and for such internal control that the Board of Directors and the Managing Director determine is necessary to prepare the Esef report without material misstatements, whether due to fraud or error.

#### AUDITOR'S RESPONSIBILITY

Our responsibility is to obtain reasonable assurance whether the Esef report is in all material respects prepared in a format that meets the requirements of Chapter 16, Section 4(a) of the Swedish Securities Market Act (2007:528), based on the procedures performed.

RevR 18 requires us to plan and execute procedures to achieve reasonable assurance that the Esef report is prepared in a format that meets these requirements.

Reasonable assurance is a high level of assurance, but it is not a guarantee that an engagement carried out according to RevR 18 and generally accepted auditing standards in Sweden will always detect a material misstatement when it exists. Misstatements can arise from fraud or error and are considered material if, individually or in aggregate, they could reasonably be expected to influence the economic decisions of users taken on the basis of the ESEF report.

The firm applies International Standard on Quality Management 1, which requires the firm to design, implement and operate a system of quality management including policies or procedures regarding compliance with ethical requirements, professional standards and applicable legal and regulatory requirements.

The examination involves obtaining evidence, through various procedures, that the Esef report has been prepared in a format that enables uniform electronic reporting of the annual accounts and consolidated accounts. The procedures

selected depend on the auditor's judgment, including the assessment of the risks of material misstatement in the report, whether due to fraud or error. In carrying out this risk assessment, and in order to design audit procedures that are appropriate in the circumstances, the auditor considers those elements of internal control that are relevant to the preparation of the Esef report by the Board of Directors and the Managing Director, but not for the purpose of expressing an opinion on the effectiveness of those internal controls. The examination also includes an evaluation of the appropriateness and reasonableness of assumptions made by the Board of Directors and the Managing Director.

The procedures mainly include a validation that the Esef report has been prepared in a valid XHTML format and a reconciliation of the Esef report with the audited annual accounts and consolidated accounts.

Furthermore, the procedures also include an assessment of whether the consolidated statement of financial performance, financial position, changes in equity, cash flow and disclosures in the Esef report have been marked with iXBRL in accordance with what follows from the Esef regulation.

#### THE AUDITOR'S EXAMINATION OF THE CORPORATE GOVERNANCE STATEMENT

The Board of Directors is responsible for that the corporate governance statement on pages 84–89 has been prepared in accordance with the Annual Accounts Act.

Our examination of the corporate governance statement is conducted in accordance with FAR's auditing standard RevR 16 The auditor's examination of the corporate governance statement. This means that our examination of the corporate governance statement is different and substantially less in scope than an audit conducted in accordance with International Standards on Auditing and generally accepted auditing standards in Sweden. We believe that the examination has provided us with sufficient basis for our opinions.

A corporate governance statement has been prepared. Disclosures in accordance with chapter 6 section 6 the second paragraph points 2-6 of the Annual Accounts Act and chapter 7 section 31 the second paragraph the same law are consistent with the other parts of the annual accounts and consolidated accounts and are in accordance with the Annual Accounts Act.

Öhrlings PricewaterhouseCoopers AB, 113 97 Stockholm, was appointed auditor of Thule Group AB (publ) by the general meeting of the shareholders on the 26 April 2024 and has been the company's auditor since the 26 April 2017.

Malmö, 7 April 2025

Öhrlings PricewaterhouseCoopers AB

Sofia Götmar-Blomstedt  
Authorized Public Accountant  
Auditor-in-charge

Neda Feher  
Authorized Public Accountant

This is a translation of the Swedish language original. In the event of any differences between this translation and the Swedish language original, the latter shall prevail.

# About the Sustainability Report

**The sustainability report for Thule Group (publ) is part of the 2024 Annual and Sustainability Report and the information pertains to January 1, 2024 – December 31, 2024. The report includes all manufacturing sites and offices.**

In the 2023 Annual Report, we published a DMA. Since then, we have reviewed the impacts, risk and opportunities related to the DMA we conducted in 2023. The 2024 DMA is aligned with the requirements of the European Sustainability Reporting Standards.

In the DMA, we assessed Thule Group's significant actual and potential, positive and negative impacts on people and the environment, as well as actual and potential financial impacts, risks and opportunities. The scoping of sub-topics and sub-subtopics has been done based on analyses of the company's business model through the perspective of upstream value chain, own operations and downstream value chain. For the DMA conducted in 2024, impacts were considered only from tier 1 of the upstream value chain. This approach establishes a clear reporting boundary for 2024, enabling a more in-depth analysis of the business activities and impacts of tier 1 suppliers. It will also help delineate and map other impacts, such as those related to water and biodiversity, for suppliers further upstream in the value chain. In 2025, the scope of analysis and reporting will expand to beyond tier 1.

The results of the 2023 DMA were shared with 102 stakeholders, consisting of both affected stakeholders, and stakeholders that can affect Thule Group. The recipients included investors,

Board members, suppliers, customers and other stakeholders.

A total of 30 responded, which is less than our previous stakeholder survey, whereby 163 stakeholders responded.

The most important sustainability matters that were identified by stakeholders is climate change impacts, such as reducing GHG emissions, supply chain due diligence, and health and safety.

Internal stakeholders also highlighted human rights, logistics, and waste as a key area of focus. The clearest change from earlier surveys indicate that GHG emissions have become increasingly significant.

The results from the stakeholder survey are shared with the Board and Group Management, to ensure that Group level ESG targets are aligned with the views of the stakeholders.

Our 2024 sustainability report is inspired by the ESRS, and the amended DMA in 2024 is reviewed and approved by the Board of Directors, and the Group Management.

A new stakeholder dialog will be conducted in 2025, where all stakeholders will be updated on the sustainability issues that Thule Group plans to report on. Their interests and concerns will be taken into account when the double materiality assessment is reviewed again in 2025.

**Contact for the Sustainability Report:**

Hawwa Nashfa  
hawwa.nashfa@thule.com

# ESRS Disclosures

<b>ESRS 2</b>		<b>Pages</b>
BP-1	General basis for preparation of sustainability statements	38
BP-2	Disclosures in relation to specific circumstances	38
<b>Governance</b>		
GOV-1	The role of the administrative, management and supervisory bodies	84-87
GOV-2	Information provided to and sustainability matters addressed by the undertaking's administrative, management and supervisory bodies	86
GOV-3	Integration of sustainability-related performance in incentive schemes	108
GOV-4	Statement on due diligence	35, 70-71
GOV-5	Risk management and internal controls over sustainability reporting	70-71
<b>Strategy</b>		
SBM-1	Strategy, business model and value chain	35-37
SBM-2	Interests and views of stakeholders	38, 66-67, 70-71
SBM-3	Material impacts, risks and opportunities and their interaction with strategy and business model	35-38
<b>Impact, risk and opportunity management</b>		
IRO-1	Description of the processes to identify and assess material impacts, risks and opportunities	75
IRO-2	Disclosure requirements in ESRS covered by the undertaking's sustainability statement	38
<b>Environment</b>		<b>Pages</b>
<b>E1 Climate Change</b>		
E1-1	Transition plan for climate change mitigation	42, 46-47
E1-2	Policies related to climate change mitigation and adaptation	42
E1-3	Actions and resources in relation to climate change policies	43
E1-4	Targets related to climate change mitigation and adaptation	42, 46-47
E1-5	Energy consumption and mix	43
E1-6	Gross Scopes 1, 2, 3 and Total GHG emissions	44
<b>E2 Pollution</b>		
E2-1	Policies related to pollution	50
E2-2	Actions and resources related to pollution	51
E2-3	Targets related to pollution	51-54
E2-5	Substances of concern and substances of very high concern	51

<b>Environment</b>		<b>Pages</b>
<b>E5 Resource use and circular economy</b>		
E5-1	Policies related to resource use and circular economy	42, 43
E5-2	Actions and resources related to resource use and circular economy	52
E5-3	Targets related to resource use and circular economy	54
E5-4	Resource inflows	54
E5-5	Resource outflows	55
E5-6	Potential financial effects from resource use and circular economy-related impacts, risks and opportunities	56
<b>Social</b>		<b>Pages</b>
<b>S1 Own Workforce</b>		
S1-1	Policies related to own workforce	59, 64, 71
S1-2	Processes for engaging with own workers and workers' representatives about impacts	60
S1-3	Processes to remediate negative impacts and channels for own workers to raise concerns	71
S1-4	Taking action on material impacts on own workforce, and approaches to mitigating material risks and pursuing material opportunities related to own workforce, and effectiveness of those actions	59-63
S1-5	Targets related to managing material negative impacts, advancing positive impacts, and managing material risks and opportunities	57-60
S1-6	Characteristics of the undertaking's employees	61
S1-7	Characteristics of non-employee workers in the undertaking's own workforce	61
S1-9	Diversity metrics	62
S1-10	Adequate wages	62
S1-11	Social protection	62
S1-13	Training and skills development metrics	62
S1-14	Health and safety metrics	63
S1-15	Work-life balance metrics	63
S1-16	Compensation metrics (pay gap and total compensation)	62
S1-17	Incidents, complaints and severe human rights impacts	63
<b>S2 Workers in the value chain</b>		
S2-1	Policies related to value chain workers	64, 71
S2-2	Processes for engaging with value chain workers about impacts	70, 71

<b>Social</b>		<b>Pages</b>
S2-3	Processes to remediate negative impacts and channels for value chain workers to raise concerns	71
S2-4	Taking action on material impacts on value chain workers, and approaches to managing material risks and pursuing material opportunities related to value chain workers, and effectiveness of those actions	37, 63, 65, 67
S2-5	Targets related to managing material negative impacts, advancing positive impacts, and managing material risks and opportunities	65, 76-81
<b>S4 Consumers and end-users</b>		
S4-1	Policies related to consumers and end-users	66, 67
S4-2	Processes for engaging with consumers and end-users about impacts	66, 67
S4-3	Processes to remediate negative impacts and channels for consumers and end-users to raise concerns	66, 67
S4-4	Taking action on material impacts on consumers and end-users, and approaches to managing material risks and pursuing material opportunities related to consumers and end-users, and effectiveness of those actions	66, 67
S4-5	Targets related to managing material negative impacts, advancing positive impacts, and managing material risks and opportunities	66, 67
<b>Governance</b>		<b>Pages</b>
<b>G1 Business conduct</b>		
G1-1	Corporate culture and business conduct policies and corporate culture	70, 71
G1-3	Prevention and detection of corruption and bribery	71
G1-4	Confirmed incidents of corruption or bribery	63

## Data points that derive from other EU legislation

Disclosure requirement and related datapoint	Sfdr reference	Pillar 3 reference	Benchmark regulation reference	EU climate law reference	Page reference/ not material
ESRS 2 GOV-1 Board's gender diversity paragraph 21 (d)	Indicator number 13 of Table #1 of Annex I		Commission Delegated Regulation (EU) 2020/1816, Annex II		62
ESRS 2 GOV-1 Percentage of board members who are independent paragraph 21 (e)			Delegated Regulation (EU) 2020/1816, Annex II		85, 86
ESRS 2 GOV-4 Statement on due diligence paragraph 30	Indicator number 10 Table #3 of Annex I				35
ESRS 2 SBM-1 Involvement in activities related to fossil fuel activities paragraph 40 (d) i	Indicators number 4 Table #1 of Annex I	Article 449a Regulation (EU) No 575/2013; Commission Implementing Regulation (EU) 2022/2453 Table 1: Qualitative information on Environmental risk and Table 2: Qualitative information on Social risk	Delegated Regulation (EU) 2020/1816, Annex II		43
ESRS 2 SBM-1 Involvement in activities related to chemical production paragraph 40 (d) ii	Indicator number 9 Table #2 of Annex I		Delegated Regulation (EU) 2020/1816, Annex II		Not material
ESRS 2 SBM-1 Involvement in activities related to controversial weapons paragraph 40 (d) iii	Indicator number 14 Table #1 of Annex I		Delegated Regulation (EU) 2020/1818, Article 12(1) Delegated Regulation (EU) 2020/1816, Annex II		Not material
ESRS 2 SBM-1 Involvement in activities related to cultivation and production of tobacco paragraph 40 (d) iv			Delegated Regulation (EU) 2020/1818, Article 12(1) Delegated Regulation (EU) 2020/1816, Annex II		Not material
ESRS E1-1 Transition plan to reach climate neutrality by 2050 paragraph 14				Regulation (EU) 2021/1119 Article 2(1)	13, 42, 46, 47
ESRS E1-1 Undertakings excluded from Paris-aligned Benchmarks paragraph 16 (g)		Article 449a Regulation (EU) No 575/2013; Commission Implementing Regulation (EU) 2022/2453 Template 1: Banking book- Climate Change transition risk: Credit quality of exposures by sector, emissions and residual maturity	Article 12.1 (d) to (g), and Article 12.2		13, 42, 46, 47
ESRS E1-4 GHG emission reduction targets paragraph 34	Indicator number 4 Table #2 of Annex I	Article 449a Regulation (EU) No 575/2013; Commission Implementing Regulation (EU) 2022/2453 Template 3: Banking book- Climate change transition risk: alignment metrics	Delegated Regulation (EU) 2020/1818, Article 6		13, 42
ESRS E1-5 Energy consumption from fossil sources disaggregated by sources (only high climate impact sectors)	Indicator number 5 Table #1 and Indicator n. 5 Table #2 of Annex I				43
ESRS E1-5 Energy consumption and mix paragraph 37	Indicator number 5 Table #1 of Annex I				43
ESRS E1-5 Energy intensity associated with activities in high climate impact sectors paragraphs 40 to 43	Indicator number 6 Table #1 of Annex I				43
ESRS E1-6 Gross Scope 1, 2, 3 and Total GHG emissions paragraph 44	Indicators number 1 and 2 Table #1 of Annex I	Article 449a; Regulation (EU) No 575/2013; Commission Implementing Regulation (EU) 2022/2453 Template 1: Banking book- Climate change transition risk: Credit quality of exposures by sector, emissions and residual maturity	Delegated Regulation (EU) 2020/1818, Article 5(1), 6 and 8(1)		44
ESRS E1-6 Gross GHG emissions intensity paragraphs 53 to 55	Indicators number 3 Table #1 of Annex I	Article 449a Regulation (EU) No 575/2013; Commission Implementing Regulation (EU) 2022/2453 Template 3: Banking book- Climate change transition risk: alignment metrics	Delegated Regulation (EU) 2020/1818, Article 8(1)		44
ESRS E1-7 GHG removals and carbon credits paragraph 56				Regulation (EU) 2021/1119, Article 2(1)	Not material
ESRS E1-9 Exposure of the benchmark portfolio to climate-related physical risks paragraph 66			Delegated Regulation (EU) 2020/1818, Annex II Delegated Regulation (EU) 2020/1816, Annex II		Not material
ESRS E1-9 Disaggregation of monetary amounts by acute and chronic physical risk paragraph 66 (a) ESRS E1-9 Location of significant assets at material physical risk paragraph 66 (c).		Article 449a Regulation (EU) No 575/2013; Commission Implementing Regulation (EU) 2022/2453 paragraphs 46 and 47; Template 5: Banking book- Climate change physical risk: Exposures subject to physical risk.			Not material

Disclosure requirement and related datapoint	Sfdr reference	Pillar 3 reference	Benchmark regulation reference	EU climate law reference	Page reference/ not material
ESRS E1-9 Breakdown of the carrying value of its real estate assets by energy-efficiency classes paragraph 67 (c).		Commission Implementing Regulation (EU) 2022/2453 paragraph 34; Template 2: Banking book- Climate change transition risk: Loans collateralised by immovable property- Energy efficiency of the collateral			Not material
ESRS E1-9 Degree of exposure of the portfolio to climate-related opportunities paragraph 69			Delegated Regulation (EU) 2020/1818, Annex II		Not material
ESRS E2-4 Amount of each pollutant listed in Annex II of the E-PRTR Regulation (European Pollutant Release and Transfer Register) emitted to air, water and soil, paragraph 28	Indicator number 8 Table #1 of Annex I Indicator number 2 Table #2 of Annex I Indicator number 1 Table #2 of Annex I Indicator number 3 Table #2 of Annex I				Not material
ESRS E3-1 Water and marine resources paragraph 9	Indicator number 7 Table #2 of Annex I				Not material
ESRS E3-1 Dedicated policy paragraph 13	Indicator number 8 Table 2 of Annex I				Not material
ESRS E3-1 Sustainable oceans and seas paragraph 14	Indicator number 12 Table #2 of Annex I				Not material
ESRS E3-4 Total water recycled and reused paragraph 28 (c)	Indicator number 6.2 Table #2 of Annex I				Not material
ESRS E3-4 Total water consumption in m3 per net revenue on own operations paragraph 29	Indicator number 6.1 Table #2 of Annex I				Not material
ESRS 2- IRO 1 - E4 paragraph 16 (a) i	Indicator number 7 Table #1 of Annex I				Not material
ESRS 2- IRO 1 - E4 paragraph 16 (b)	Indicator number 10 Table #2 of Annex I				Not material
ESRS 2- IRO 1 - E4 paragraph 16 (c)	Indicator number 14 Table #2 of Annex I				Not material
ESRS E4-2 Sustainable land / agriculture practices or policies paragraph 24 (b)	Indicator number 11 Table #2 of Annex I				Not material
ESRS E4-2 Sustainable oceans / seas practices or policies paragraph 24 (c)	Indicator number 12 Table #2 of Annex I				Not material
ESRS E4-2 Policies to address deforestation paragraph 24 (d)	Indicator number 15 Table #2 Annex I				Not material
ESRS E5-5 Non-recycled waste paragraph 37 (d)	Indicator number 13 Table #2 of Annex I				55
ESRS E5-5 Hazardous waste and radioactive waste paragraph 39	Indicator number 9 Table #1 of Annex I				55
ESRS 2- SBM3 - S1 Risk of incidents of forced labour paragraph 14 (f)	Indicator number 13 Table #3 of Annex I				63, 64
ESRS 2- SBM3 - S1 Risk of incidents of child labour paragraph 14 (g)	Indicator number 12 Table #3 of Annex I				63, 64
ESRS S1-1 Human rights policy commitments paragraph 20	Indicators number 9 Table #3 and Indicator number 11 Table #1 of Annex I				59, 60, 64
ESRS S1-1 Due diligence policies on issues addressed by the fundamental International Labor Organisation Conventions 1 to 8, paragraph 21			Delegated Regulation (EU) 2020/1816, Annex II		59, 60, 64
ESRS S1-1 processes and measures for preventing trafficking in human beings paragraph 22	Indicator number 11 Table #3 of Annex I				59, 60, 64
ESRS S1-1 workplace accident prevention policy or management system paragraph 23	Indicator number 1 Table #3 of Annex I				60, 63
ESRS S1-3 grievance/complaints handling mechanisms paragraph 32 (c)	Indicator number 5 Table #3 of Annex I				59, 71
ESRS S1-14 Number of fatalities and number and rate of work-related accidents paragraph 88 (b) and (c)	Indicator number 2 Table #3 of Annex I		Delegated Regulation (EU) 2020/1816, Annex II		62
ESRS S1-14 Number of days lost to injuries, accidents, fatalities or illness paragraph 88 (e)	Indicator number 3 Table #3 of Annex I				62
ESRS S1-16 Unadjusted gender pay gap paragraph 97 (a)	Indicator number 12 Table #1 of Annex I		Delegated Regulation (EU) 2020/1816, Annex II		63
ESRS S1-16 Excessive CEO pay ratio paragraph 97 (b)	Indicator number 8 Table #3 of Annex I				63
ESRS S1-17 Incidents of discrimination paragraph 103 (a)	Indicator number 7 Table #3 of Annex I				63
ESRS S1-17 Non-respect of UNGP's on Business and Human Rights and OECD paragraph 104 (a)	Indicator number 10 Table #1 and Indicator n. 14 Table #3 of Annex I		Delegated Regulation (EU) 2020/1816, Annex II Delegated Regulation (EU) 2020/1818 Art 12 (1)		63
ESRS 2- SBM3 – S2 Significant risk of child labour or forced labour in the value chain paragraph 11 (b)	Indicators number 12 and n. 13 Table #3 Annex I				63

Disclosure requirement and related datapoint	Sfdr reference	Pillar 3 reference	Benchmark regulation reference	EU climate law reference	Page reference/ not material
ESRS S2-1 Human rights policy commitments paragraph 17	Indicator number 9 Table #3 and Indicator n. 11 Table #1 of Annex I				71, 77
ESRS S2-1 Policies related to value chain workers paragraph 18	Indicator number 11 and n. 4 Table #3 of Annex I				64, 71
ESRS S2-1 Non-respect of UNGP's on Business and Human Rights principles and OECD guidelines paragraph 19	Indicator number 10 Table #1 of Annex I		Delegated Regulation (EU) 2020/1816, Annex II Delegated Regulation (EU) 2020/1818, Art 12 (1)		59-60, 64
ESRS S2-1 Due diligence policies on issues addressed by the fundamental International Labor Organisation Conventions 1 to 8, paragraph 19			Delegated Regulation (EU) 2020/1816, Annex II		59-60, 64
ESRS S2-4 Human rights issues and incidents connected to its upstream and downstream value chain paragraph 36	Indicator number 14 Table #3 of Annex I				37, 63, 65, 77
ESRS S3-1 Human rights policy commitments paragraph 16	Indicator number 9 Table #3 of Annex I and Indicator number 11 Table #1 of Annex 1				Not material
ESRS S3-1 non-respect of UNGP's on Business and Human Rights, ILO principles or and OECD guidelines paragraph 17	Indicator number 10 Table #1 Annex I		Delegated Regulation (EU) 2020/1816, Annex II Delegated Regulation (EU) 2020/1818, Art 12 (1)		Not material
ESRS S3-4 Human rights issues and incidents paragraph 36	Indicator number 14 Table #3 of Annex I				Not material
ESRS S4-1 Policies related to consumers and end-users paragraph 16	Indicator number 9 Table #3 and Indicator number 11 Table #1 of Annex I				66-67
ESRS S4-1 Non-respect of UNGP's on Business and Human Rights and OECD guidelines paragraph 17	Indicator number 10 Table #1 of Annex I		Delegated Regulation (EU) 2020/1816, Annex II Delegated Regulation (EU) 2020/1818, Art 12 (1)		66-67
ESRS S4-4 Human rights issues and incidents paragraph 35	Indicator number 14 Table #3 of Annex I				66-67
ESRS G1-1 United Nations Convention against Corruption paragraph 10 (b)	Indicator number 15 Table #3 of Annex I				68-71
ESRS G1-1 Protection of whistle- blowers paragraph 10 (d)	Indicators number 6 Table #3 of Annex I				71
ESRS G1-4 Fines for violation of anti-corruption and anti-bribery laws paragraph 24 (a)	Indicator number 17 Table #3 of Annex I		Delegation Regulation (EU) 2020/1816, Annex II		71
ESRS G1-4 Standards of anti- corruption and anti- bribery paragraph 24 (b)	Indicator number 16 Table #3 of Annex I				70-71

# Taxonomy tables

## Proportion of turnover from products or services associated with Taxonomy-aligned economic activities – disclosure covering 2024

January 1st–December 31st				Substantial Contribution Criteria						DNSH* criteria (h)						Minimum Safeguards (17)	Proportion of Taxonomy aligned (A.1.) or eligible (A.2.) Turnover, 2023 (18)	Category enabling activity (19)	Category transitional activity (20)
Economic Activities (1)	Code (a) (2)	Turnover, SEKm (3)	Proportion of Turnover (4)	Climate Change Mitigation (5)	Climate Change Adaptation (6)	Water (7)	Pollution (8)	Circular Economy (9)	Biodiversity (10)	Climate Change Mitigation (11)	Climate Change Adaptation (12)	Water (13)	Pollution (14)	Circular Economy (15)	Biodiversity (16)				
Total Revenue		9,541.00	%	Y/N;N/EL (b)(c)	Y/N;N/EL (b)(c)	Y/N;N/EL (b)(c)	Y/N;N/EL (b)(c)	Y/N;N/EL (b)(c)	Y/N;N/EL (b)(c)	Y	Y	Y	Y	Y	Y/N	Y/N	%	E	T

A. Taxonomy-eligible activities																				
A.1. Environmentally sustainable activities (Taxonomy-aligned)																				
5.1 Sales of spareparts		79.00	0.80	N/EL	N/EL	N/EL	N/EL	Y	N/EL	Y	Y	Y	Y	Y	Y	Y	Y	0	E	
<b>Turnover of environmentally sustainable activities (Taxonomy-aligned) (A.1)</b>		79.00	0.80	N	N	N	N	Y	N	Y	Y	Y	Y	Y	Y	Y	Y	0		
Of which Enabling		79.00	0.80	N	N	N	N	Y	N	Y	Y	Y	Y	Y	Y	Y	Y	0	E	
Of which Transitional		0.00	0.00							–	–	–	–	–	–	–	–	0		
A.2 Taxonomy-Eligible but not environmentally sustainable activities (not Taxonomy-aligned activities) (g)																				
				EL; N/EL (f)	EL; N/EL (f)	EL; N/EL (f)	EL; N/EL (f)	EL; N/EL (f)	EL; N/EL (f)											
<b>Turnover of Taxonomy- eligible but not environmentally sustainable activities (not Taxonomy-aligned activities) (A.2)</b>		0.00	0.00															0		
<b>A. Turnover of Taxonomy eligible activities (A1+A2)</b>		79	0.80	0%	0%	0%	0%	0.8%	0%	0%	0%	0%	0%	0%	0%	0%	0%	0%	0%	0%

B. Taxonomy-non-eligible activities			
Turnover of Taxonomy-non-eligible activities		9,462.00	99.00
<b>Total</b>		<b>9,541.00</b>	<b>100.00</b>

\* Does Not Significantly Harm  
Y – Yes, Taxonomy-eligible and Taxonomy-aligned activity with the relevant environmental objective.  
N – No, Taxonomy-eligible but not Taxonomy-aligned activity with the relevant environmental objective.  
N/EL – not eligible, Taxonomy non-eligible activity for the relevant environmental objective.

# Taxonomy tables – CapEx

Proportion of CapEx from products or services associated with Taxonomy-aligned economic activities – disclosure covering 2024

January 1st–December 31st				Substantial Contribution Criteria						DNSH* criteria (h)						Minimum Safeguards (17)	Proportion of Taxonomy aligned (A.1.) or eligible (A.2.) CapEx, 2023 (18)	Category enabling activity (19)	Category transitional activity (20)
Economic Activities (1)	Code (a) (2)	CapEx (3)	Proportion of CapEx (4)	Climate Change Mitigation (5)	Climate Change Adaptation (6)	Water (7)	Pollution (8)	Circular Economy (9)	Biodiversity (10)	Climate Change Mitigation (11)	Climate Change Adaptation (12)	Water (13)	Pollution (14)	Circular Economy (15)	Biodiversity (16)				
		SEKM	%	Y/N;N/EL (b)(c)	Y/N;N/EL (b)(c)	Y/N;N/EL (b)(c)	Y/N;N/EL (b)(c)	Y/N;N/EL (b)(c)	Y/N;N/EL (b)(c)	Y/N	Y/N	Y/N	Y/N	Y/N	Y/N				

A. Taxonomy-eligible activities																				
A.1. Environmentally sustainable activities (Taxonomy-aligned)																				
2.2 Water Waste Management	CE2.2	0.06	0.02	N/EL	N/EL	N/EL	N/EL	Y	N/EL	Y	Y	Y	Y	Y	Y	Y	Y	0.00	E	
7.1 Construction of new buildings	CCM7.1/CE3.1	6.40	1.76	Y	N/EL	N/EL	N/EL	N	N/EL	Y	Y	Y	Y	Y	Y	Y	Y	0.50		T
7.2 Renovation of existing buildings	CCM7.2/CE3.1	0.00	0.00	Y	N/EL	N/EL	N/EL	N	N/EL	Y	Y	Y	Y	Y	Y	Y	Y	1.20	E	
7.3 Installation, maintenance and repair of energy efficiency equipment	CCM7.3	1.97	0.54	Y	N/EL	N/EL	N/EL	N/EL	N/EL	Y	Y	Y	Y	Y	Y	Y	Y	1.00	E	
7.4 Installation, maintenance and repair of charging stations for electric vehicles in buildings (and parking spaces attached to buildings)	CCM7.4	1.39	0.38	Y	N/EL	N/EL	N/EL	N/EL	N/EL	Y	Y	Y	Y	Y	Y	Y	Y	0.80	E	
7.6 Installation, maintenance and repair of renewable energy technologies	CCM7.6	20.00	5.51	Y	N/EL	N/EL	N/EL	N/EL	N/EL	Y	Y	Y	Y	Y	Y	Y	Y	2.80		T
<b>CapEx of environmentally sustainable activities (Taxonomy-aligned) (A.1)</b>		<b>29.82</b>	<b>8.21</b>	<b>8,20%</b>	<b>0%</b>	<b>0%</b>	<b>0%</b>	<b>0.02%</b>	<b>0%</b>	<b>Y</b>	<b>Y</b>	<b>Y</b>	<b>Y</b>	<b>Y</b>	<b>Y</b>	<b>Y</b>	<b>Y</b>	<b>6.30</b>		
Of which Enabling		3.42	0.94	0,93%	0.00	0.00	0.00	0.02%	0.00	Y	Y	Y	Y	Y	Y	Y	Y	3.00	E	
Of which Transitional		26.40	7.27	5,51%				0.00		Y	Y	Y	Y	Y	Y	Y	Y	3.30		T
A.2 Taxonomy-Eligible but not environmentally sustainable activities (not Taxonomy-aligned activities) (g)																				
2.2 Water Waste Management	CE2.2	0.00	0.00	N/EL	N/EL	N/EL	N/EL	EL	N/EL	Y	Y	Y	Y	Y	Y	Y	Y	0.00	E	
7.1 Construction of new buildings	CCM7.1/CE3.1	0.00	0.00	EL	N/EL	N/EL	N/EL	N/EL	N/EL	Y	Y	Y	Y	Y	Y	Y	Y	3.30		T
7.2 Renovation of existing buildings	CCM7.2/CE3.1	0.00	0.00	EL	N/EL	N/EL	N/EL	EL	N/EL	Y	Y	Y	Y	Y	Y	Y	Y	1.30	E	
7.3 Installation, maintenance and repair of energy efficiency equipment	CCM7.3	0.16	0.04	EL	N/EL	N/EL	N/EL	N/EL	N/EL	Y	Y	Y	Y	Y	Y	Y	Y	1.50	E	
7.4 Installation, maintenance and repair of charging stations for electric vehicles in buildings (and parking spaces attached to buildings)	CCM7.4	0.00	0.00	EL	N/EL	N/EL	N/EL	N/EL	N/EL	Y	Y	Y	Y	Y	Y	Y	Y	0.80	E	
7.6 Installation, maintenance and repair of renewable energy technologies	CCM7.6	0.00	0.00	EL	N/EL	N/EL	N/EL	N/EL	N/EL	Y	Y	Y	Y	Y	Y	Y	Y	3.00		T
<b>CapEx of Taxonomy- eligible but not environmentally sustainable activities (not Taxonomy-aligned activities) (A.2)</b>		<b>0.16</b>	<b>0.04</b>	<b>EL</b>	<b>EL</b>	<b>N/EL</b>	<b>N/EL</b>	<b>N/EL</b>	<b>N/EL</b>									<b>10.00</b>		
<b>A. CapEx of Taxonomy eligible activities (A1+A2)</b>		<b>29.98</b>	<b>8.26</b>	<b>8,24%</b>	<b>0,00%</b>	<b>0,00%</b>	<b>0,00%</b>	<b>0,02%</b>	<b>0,00%</b>									<b>16.00</b>		

B. Taxonomy-non-eligible activities			
CapEx of Taxonomy-non-eligible activities		333.02	91.74
<b>Total</b>		<b>363.00</b>	<b>100</b>

\* Does Not Significantly Harm  
Y – Yes, Taxonomy-eligible and Taxonomy-aligned activity with the relevant environmental objective.  
N – No, Taxonomy-eligible but not Taxonomy-aligned activity with the relevant environmental objective.  
N/EL – not eligible, Taxonomy non-eligible activity for the relevant environmental objective.

# Taxonomy tables – OpEx

Proportion of OpEx from products or services associated with Taxonomy-aligned economic activities – disclosure covering 2024

January 1st–December 31st				Substantial Contribution Criteria						DNSH* criteria (h)						Minimum Safeguards (17)	Proportion of Taxonomy aligned (A.1.) or eligible (A.2.) OpEx, 2022 (18)	Category enabling activity (19)	Category transitional activity (20)
Economic Activities (1)	Code (a) (2)	OpEx (3)	Proportion of OpEx (4)	Climate Change Mitigation (5)	Climate Change Adaptation (6)	Water (7)	Pollution (8)	Circular Economy (9)	Biodiversity (10)	Climate Change Mitigation (11)	Climate Change Adaptation (12)	Water (13)	Pollution (14)	Circular Economy (15)	Biodiversity (16)				
		SEKM	%	Y/N;N/EL (b)(c)	Y/N;N/EL (b)(c)	Y/N;N/EL (b)(c)	Y/N;N/EL (b)(c)	Y/N;N/EL (b)(c)	Y/N;N/EL (b)(c)	Y/N	Y/N	Y/N	Y/N	Y/N	Y/N	Y/N	%	E	T

A. Taxonomy-eligible activities																				
A.1. Environmentally sustainable activities (Taxonomy-aligned)																				
2.3 Collection & transport of non-hazardous & haza	CE2.3	5.75	4.36	N/EL	N/EL	N/EL	N/EL	Y	N/EL	Y	Y	Y	Y	Y	Y	Y	Y	0	E	
7.2 Renovation of existing buildings	CCM7.2/CE3.1	2.31	1.75	Y	N/EL	N/EL	N/EL	N	N/EL	Y	Y	Y	Y	Y	Y	Y	Y	0.20	E	
7.3 Installation, maintenance and repair of energy efficiency equipment	CCM7.3	1.86	1.41	Y	N/EL	N/EL	N/EL	N/EL	N/EL	Y	Y	Y	Y	Y	Y	Y	Y	2.2	E	
7.4 Installation, maintenance and repair of charging stations for electric vehicles in buildings (and parking spaces attached to buildings)	CCM7.4	0.08	0.06	Y	N/EL	N/EL	N/EL		N/EL	Y	Y	Y	Y	Y	Y	Y	Y	0	E	
7.5 Installation, maintenance and repair of instruments and devices for measuring, regulation and controlling energy performance of buildings	CCM7.5	0.00	0.00	Y	N/EL	N/EL	N/EL	N/EL	N/EL	Y	Y	Y	Y	Y	Y	Y	Y	0	E	
7.6 Installation, maintenance and repair of renewable energy technologies	CCM7.6	0.22	0.17	Y	N/EL	N/EL	N/EL	N	N/EL	Y	Y	Y	Y	Y	Y	Y	Y	0.4		T
<b>OpEx of environmentally sustainable activities (Taxonomy-aligned) (A.1)</b>		<b>10.22</b>	<b>7.75</b>	<b>3.39%</b>	<b>0.00%</b>	<b>0%</b>	<b>0%</b>	<b>4.36%</b>	<b>0%</b>	<b>Y</b>	<b>Y</b>	<b>Y</b>	<b>Y</b>	<b>Y</b>	<b>Y</b>	<b>Y</b>	<b>Y</b>	<b>2.80</b>		
Of which Enabling		10.00	7.60	0	0	0	0	0	0	Y	Y	Y	Y	Y	Y	Y	Y	2.4	0	
Of which Transitional		0.22	0.17	0						Y	Y	Y	Y	Y	Y	Y	Y	3.20		0
A.2 Taxonomy-Eligible but not environmentally sustainable activities (not Taxonomy-aligned activities) (g)																				
7.5 Installation, maintenance and repair of instruments and devices for measuring, regulation and controlling energy performance of buildings	CCM7.5	0.02	0.01	EL	N/EL	N/EL	N/EL	N	N/EL									0		
<b>OpEx of Taxonomy- eligible but not environmentally sustainable activities (not Taxonomy-aligned activities) (A.2)</b>		<b>0.02</b>	<b>0.01</b>	<b>0.01%</b>	<b>0.00%</b>	<b>0%</b>	<b>0%</b>	<b>0%</b>	<b>0%</b>									<b>0</b>		
<b>A. OpEx of Taxonomy eligible activities (A1+A2)</b>		<b>10.24</b>	<b>7.77</b>	<b>3.40%</b>	<b>0%</b>	<b>0%</b>	<b>0%</b>	<b>4.36%</b>	<b>0%</b>											

B. Taxonomy-non-eligible activities			
OpEx of Taxonomy-non-eligible activities		121.66	92
Total		131.90	100

\* Does Not Significantly Harm  
 Y – Yes, Taxonomy-eligible and Taxonomy-aligned activity with the relevant environmental objective.  
 N – No, Taxonomy-eligible but not Taxonomy-aligned activity with the relevant environmental objective.  
 N/EL – not eligible, Taxonomy non-eligible activity for the relevant environmental objective.

## EU Taxonomy: Additional tables for economic activities that contribute to the majority of the environmental objectives

Proportion of turnover/Total turnover	Taxonomy-aligned per objective	Taxonomy-eligible per objective
CCM	0.0	0.0
CCA	0.0	0.0
WTR	0.0	0.0
CE	0.8	0.0
PPC	0.0	0.0
BIO	0.0	0.0

Proportion of CapEx/Total CapEx	Taxonomy-aligned per objective	Taxonomy-eligible per objective
CCM	11.27	11.30
CCA	0.00	0.00
WTR	0.00	0.00
CE	0.02	0.02
PPC	0.00	0.00
BIO	0.00	0.00

Proportion of OpEx/OpEx	Taxonomy-aligned per objective	Taxonomy-eligible per objective
CCM	3.39	3.40
CCA	0.00	0.00
WTR	0.00	0.00
CE	4.36	4.36
PPC	0.00	0.00
BIO	0.00	0.00

## EU Taxonomy: Nuclear and fossil gas related activities

Nuclear energy related activities		Yes/No
1.	The undertaking carries out, funds or has exposures to research, development, demonstration and deployment of innovative electricity generation facilities that produce energy from nuclear processes with minimal waste from the fuel cycle.	No
2.	The undertaking carries out, funds or has exposures to construction and safe operation of new nuclear installations to produce electricity or process heat, including for the purposes of district heating or industrial processes such as hydrogen production, as well as their safety upgrades, using best available technologies.	No
3.	The undertaking carries out, funds or has exposures to safe operation of existing nuclear installations that produce electricity or process heat, including for the purposes of district heating or industrial processes such as hydrogen production from nuclear energy, as well as their safety upgrades.	No
Fossil gas related activities		
4.	The undertaking carries out, funds or has exposures to construction or operation of electricity generation facilities that produce electricity using fossil gaseous fuels.	No
5.	The undertaking carries out, funds or has exposures to construction, refurbishment, and operation of combined heat/cool and power generation facilities using fossil gaseous fuels.	No
6.	The undertaking carries out, funds or has exposures to construction, refurbishment and operation of heat generation facilities that produce heat/cool using fossil gaseous fuels.	No

# Auditor's report on the statutory sustainability report

This is a literal translation of the Swedish original report

**To the general meeting of the shareholders in Thule Group AB (publ), corporate identity number 556770-6311.**

## **ENGAGEMENT AND RESPONSIBILITY**

It is the board of directors who is responsible for the statutory sustainability report for the year 2024 on pages 33–71 and 125–133 and that it has been prepared in accordance with the Annual Accounts Act in accordance with the older wording that applied before 1 July 2024.

## **THE SCOPE OF THE AUDIT**

Our examination has been conducted in accordance with FAR's auditing standard RevR 12 The auditor's opinion regarding the statutory

sustainability report. This means that our examination of the statutory sustainability report is substantially different and less in scope than an audit conducted in accordance with International Standards on Auditing and generally accepted auditing standards in Sweden. We believe that the examination has provided us with sufficient basis for our opinion.

## **OPINION**

A statutory sustainability report has been prepared.

Malmö, 7 April 2025  
Öhrlings PricewaterhouseCoopers AB

Sofia Götmar Blomstedt  
Authorized Public Accountant  
Auditor-in-charge

Neda Feher  
Authorized Public Accountant

# External sustainability assessments

The following external institutes and companies evaluate Thule Group each year in terms of sustainability and ESG results.

## CDP



CDP (Carbon Disclosure Project) is a non-profit charity that collects and compiles companies' reports on their environmental impact, governance, strategy, risks and possibilities. Thule Group completes the annual climate change questionnaire that CDP later evaluates and scores. A number of other organizations that produce sustainability assessments based on ESG use CDP as an important data source.

Thule Group was awarded a score of C in the 2024 assessment and was recognized in the top 20 percent of companies for awareness in the activity group Leisure and home manufacturing.

## DOW JONES SUSTAINABILITY EUROPE INDEX



In 2024, Thule Group was included as one of only 12 Swedish companies in the S&P Dow Jones Sustainability Europe Index (DJSI). The Dow Jones Sustainability Europe Index lists the top 20 percent of companies in terms of sustainable development among the 600 most important European companies in the S&P Global Broad Market Index. Thule Group was included in the Industry group "Consumer Durables & Apparel."

## ECOVADIS



Ecovadis is a company that supplies sustainability assessments of companies with global supply chains.

Thule Group received EcoVadis' second-highest rating of Platinum for our sustainability work. Thule Group received 82 of a maximum of 100 points and thus belongs to the best 1 percent of all (more than 65,000) companies in 160 countries reviewed by EcoVadis.

## GAIA



Gaia is a subsidiary of the French firm Ethifinance. Gaia conducts annual assessments and scores the sustainability work of SMEs.

Thule Group scored 76 out of a maximum score of 100.

## ISS-OEKOM



ISS-oekom is a company within the ISS Group that conducts annual sustainability assessments and provides ratings for global companies.

Thule Group received a rating of C+ (Prime) of the maximum A+.

## MSCI



MSCI is a global company that provides various stock market indices and assessments. Each year, MSCI ESG Research LLC assesses and evaluates Thule Group's sustainability work.

Thule Group has received the highest rating, AAA, since 2016.

## NASDAQ LISTING CENTER



Nasdaq Listing Center is a subsidiary of Nasdaq Inc., which owns and operates nine global stock exchanges. Each year, Nasdaq Listing Center collects the listed companies' ESG data to ensure stock market transparency.

Thule Group is transparent in terms of sharing ESG data and actively participates in this annual data collection by updating the data already registered and, where appropriate, updating with additional data. The Nasdaq Listing Center does not give the participating companies ratings or points, but rather collects ESG data to facilitate investors in making decisions.

## SUSTAINALYTICS



Sustainalytics is a Dutch company that uses public ESG data to assess and score companies annually on their sustainability work.

Thule Group has been given an ESG risk rating of 7.3 on a scale up to a maximum of 40+ Severe risk. The Group is assessed as being at negligible risk of ESG factors experiencing a material financial impact due to its low exposure and robust management of material ESG matters. For 2024, Thule was ranked as one of the top 50 companies globally by Sustainalytics.

# Assurance Statement: AA1000

**This is a statement from the independent assurance by South Pole of Thule Group AB's 2024 reporting of greenhouse gas (GHG) emissions.**



## BACKGROUND AND CRITERIA

The assurance provider South Pole was engaged by Thule Group AB ('Thule') to provide independent assurance of Thule Group's GHG reporting for the calendar year 2024. The GHG inventory has been developed by Thule based on GRI and Greenhouse Gas Protocol Standards. The scope of this assurance covers and is limited to GHG accounting and reporting.

The GHG Protocol Corporate Accounting and Reporting Standard (Revised Edition, 2004), and the Corporate Value Chain (Scope 3) Accounting and Reporting Standard, developed by the World Business Council for Sustainable organization Development and the World Resources Institute, have been used as criteria for reviewing Thule Group's GHG inventory. This assurance is aligned with AA1000AS v3 with Type 2 moderate-level assurance. This assurance statement has the same level of assurance as previous years from South Pole but excludes the label from AccountAbility.

## RESPONSIBILITY

Thule has sole responsibility for the content of its GHG inventory. Thus, the information reviewed is the sole responsibility of Thule. South Pole's responsibility is to provide an independent assessment of the completeness and accuracy of the GHG inventory based on the AA1000AS v3 assurance.

## INTENDED USER

The intended users of this assurance statement are, among others, the management, and stakeholders of Thule Group.

## METHODOLOGY

The greenhouse gas accounting was performed by Thule through a platform provided by a separate third-party organization. The scope of the assurance made by South Pole is the independent and objective review of these reported GHG emissions. A review of the submitted documentation was undertaken, and other available documents were checked by the members of the verification team. All data input entered into the platform were assumed correct by the South Pole team due to no visibility of raw data.

In addition to reviewing the processes by which Thule Group defines the sustainability issues relevant to and material for its operations and stakeholders, the verification process checked the following for the GHG emissions:

- definition of system boundaries and completeness of climate impact accounting;
- relevance of input data;
- accuracy of emission factors;
- accuracy of climate impact calculations of owned sources, purchased electricity and heat, and other indirect sources; and
- accuracy and reliability of assumptions.

## GHG EMISSIONS COVERED BY THE ASSURANCE

The organizational boundaries include Thule Group AB and all subsidiaries collectively referred to as 'Thule Group'. The sites along with third-party warehouses included are found below.

Location	Country	Type of facility
Malmö HQ	Sweden	HQ office, store x2 (including Stockholm store)
Itupeva	Brazil	Roof box manufacturing, offices, warehouse/DC
Calgary	Canada	Warehouse, offices
Granby	Canada	Warehouse
Rosny/Viry	France	Sales office
Neumarkt	Germany	Roof box manufacturing, offices
Forest Park	United States	Roof box manufacturing, offices
Milford	United States	Warehouse
Seymour production site (assembly)	United States	Assembly, offices
Seymour production site (fabrication)	United States	Manufacturing
Tokyo	Japan	Office
Menen	Belgium	Manufacturing, offices, warehouse
Hong Kong	Hong Kong	Sourcing office
Longmont	United States	Office, R&D
Louvain-la-Neuve	Belgium	Sales office, PB&L R&D
Veghel	Netherlands	Sales office
Haverhill	United Kingdom	Roof box manufacturing, offices, warehouse
Prague	Czech Republic	Sales office
Piła	Poland	Assembly, offices, warehouse
Huta Szklana	Poland	S&CC Manufacturing/ assembly, offices, warehouse
Hillerstorp	Sweden	S&CC Manufacturing/ assembly, R&D, offices, test centre, warehouse
Beijing	China	Sourcing office
Shanghai	China	Sourcing office
Shenzhen	China	Sourcing office
City of Industry, California	USA	Warehouse/DC (3rd party)
Venlo	Netherlands	Warehouse (3rd party)
Rest of World	China	Warehouse (3rd party)

Thule Group reports its emissions using the operational control approach. The operational boundary includes 100 % of its direct emissions, i.e., Scope 1 and Scope 2 indirect emissions, except for small offices (with less than 12 employees) and partially for Scope 3 indirect emissions. The Scope 3 indirect emissions sources included in the South Pole assurance are:

- Purchased goods and services,
- Capital goods,
- Fuel and energy-related activities,
- Upstream transportation and distribution,
- Waste,
- Business travel, and
- Downstream transportation and distribution.

The reporting period covered 1 January 2024 to 31 December 2024. Note that Thule Group made acquisitions during the reporting year 2024. These are not included in the accounting scope nor covered by the assurance statement.

**ADHERENCE TO AA1000AS PRINCIPLES**

Based on the work conducted, nothing has come to our attention demonstrating that Thule Group did not adhere to the AccountAbility Principles, as discussed below.

**INCLUSIVITY**

Thule Group's prioritized stakeholder groups include the Board of Directors, Group management, investors, employees, retailers, customers, consumers, suppliers, business partners and research institutions. A stakeholder dialogue was performed in November 2023 via an interactive ranking survey sent to several stakeholders. Stakeholder Dialogues are performed every second year, or otherwise per group management's request.

**MATERIALITY**

Most important issues identified in the 2023 stakeholder dialogue were (in order of highest to lowest): GHG emissions, supply chain (environmental impacts in the supply chain and human rights issues such as child labor and forced labor) health and safety, product, logistics and transport, waste, community, anti-corruption, diversity, water, biodiversity, governance and risk. For all aforesaid issues except biodiversity, Thule Group has data collection, progress monitoring, and in most cases relevant targets as well.

**RESPONSIVENESS**

Thule Group has formed various working groups for monitoring and reporting tasks that have been further developed and spread throughout key functions, and various sub-targets have been set for specific functions such as purchasing, logistics, supply chain, product development, and human resource. To reduce its climate impact, Thule Group has been investing in ways to reduce its dependence on fossil fuels, improve energy efficiency, and use of low-emission materials, low-emission suppliers, and activities.

Some of Thule Group's targets and their related status are outlined in Table 1.

**TABLE 1. THULE GROUP'S TARGETS AND STATUS**

Target	Achievement
Scope 1 emissions (target of 46.2% reduction by 2030 compared to 2019 base year)	Increased 21% from 3,185 tCO <sub>2</sub> e in 2019 to 3,845 tCO <sub>2</sub> e in 2024.
Scope 2 emissions (target of 100% renewable electricity through 2030) for all sites and offices with more than 12 employees	All purchased electricity for Thule Group sites and offices with more than 12 employees were certified renewable in 2024.
Scope 3 emissions (target of 28% reduction by 2030 compared to 2019 base year)	Decreased 23% from 262,940 tCO <sub>2</sub> e in 2019 to 201,932 tCO <sub>2</sub> e in 2024.

**IMPACT**

Thule Group performs an internal review quarterly of its progress in the key focus areas. The yearly results are communicated to the stakeholders in Thule Group Annual Reports. In 2024, the sustainability reporting is inspired by the ESRS.

**ADHERENCE TO GHG PROTOCOL PRINCIPLES**

Based on the scope and methods of the review, we can conclude that Thule Group calculated its carbon footprint in 2024 in accordance with the principles of the GHG Protocol.

**RELEVANCE AND COMPLETENESS**

Thule Group's carbon footprint reflects the company's GHG emissions well, and all material GHG emission sources are accounted for within the boundary, especially with the inclusion of purchased goods and services. Exclusions have been disclosed and justified.

**CONSISTENCY AND TRANSPARENCY**

Thule Group uses consistent methodologies and has provided transparent documentation on boundaries, data, assumptions, and methods used.

**ACCURACY**

The carbon footprint is deemed to have achieved sufficient accuracy. The emission factors have been chosen with a conservative approach.

**CONCLUSIONS**

Based on the boundaries of the review and the methods used, South Pole comes to the following conclusions:

1. Thule Group has calculated and reported its 2024 carbon footprint following the principles covered by the GHG Protocol Corporate Accounting and Reporting Standard.
2. Thule Group has implemented processes and procedures that follow the guidelines of the GHG Protocol and aligns with the AA1000 AccountAbility Principles Standard.
3. Based on the completed review, no issues or circumstances emerged that gave us any reason to deem that Thule Group's 2024 GHG reporting did not meet the current standard's requirements and criteria.

All relevant emission sources within the chosen system boundary were accounted for. Where estimates were deemed necessary to measure GHG emissions, Thule Group provided satisfactory comments on the mode of estimation. The emission factors, units and calculation formulas were correct.

In terms of the reliability of performance data, nothing came to our attention to suggest that these data and claims had not been properly collected from the information reported at an operational level, nor that the assumptions used were inappropriate. Thule Group has a process whereby data is collected from each site, including processed reports provided by the third-party service providers for logistics and consolidated at the Group level. The choice of assumptions and emission factors followed a conservative approach. Emission factors were derived from credible sources and were found to be applied correctly. A few updates have been

carried out by Thule Group based on findings by the verification team.

**TABLE 2. GROUP'S TOTAL CALCULATED GHG EMISSIONS 2023**

<b>Scope 1</b>	3,845 tCO <sub>2</sub> e	Location-based
		Market-based
<b>Scope 2</b>	136 tCO <sub>2</sub> e	5,327 tCO <sub>2</sub> e
<b>Scope 3</b>	201,932 tCO <sub>2</sub> e	

**RECOMMENDATIONS**

Without affecting our assurance opinion, we would also provide the following recommendations:

- Consider if the scope of calculated emissions can be revisited. Only operational waste is included, which is category 12 of the GHG Protocol, but the category end of life treatment of sold products is excluded. Since Thule is a manufacturing and product selling company the treatment of the final product will also have a climate impact.
- For 2025 calculations, please include activities and emissions from acquisitions.

**INDEPENDENCE OF ASSURANCE**

Thule Group and South Pole do not exchange any type of services that could affect their independence or cause conflict of interest for this work. South Pole was neither engaged in the data collection process nor the GHG emissions calculations.

**ABOUT SOUTH POLE**

South Pole has more than 18 years of experience in providing decarbonization pathways across a wide range of industries, sectors, and scopes. Our assurance team has extensive knowledge and experience in corporate GHG accounting, review and verification of carbon footprints, the development of carbon management plans, carbon emission reductions and carbon offsetting strategies, as well as good knowledge of relevant standards such as the GHG Protocol, ISO 14064-1, and AA1000 v3. South Pole

Stockholm, 12 March 2025

Sara Nyberg,  
Consultant

Evelina Silfverskiöld,  
Associate Consultant

# The share and shareholders

During 2024 the share value increased 24.4 percent compared with the OMXS30, which was up 3.6 percent, and the OMXSPI, up 5.7 percent. For the five-year period starting in 2019, the company's total return was 83.6 percent compared with the OMXS30GI at 60.2 percent.

Thule Group's share has been listed on Nasdaq Stockholm since November 26, 2014. As of December 31, 2024, Thule Group had 26,443 (29,120) shareholders, of whom 315 (87.5 percent of shares) were financial and institutional investors and 24,834 (27,518), representing 4.5 percent (5.0) of shares, were private Swedish individuals. Foreign owners accounted for 49.4 percent (49.5) of the votes and capital. The ten largest owners represented 46.7 percent (46.2) of the votes and capital.

The highest price paid during the period between January 1 and December 31, 2024 was SEK 367.00 (340.20) and the lowest price paid was SEK 245.50 (212.50).

As of December 31, 2024, Thule Group's share capital amounted to SEK 1,205,237.17. The number of common shares was 107,838,162. According to the Articles of Association, share capital may not amount to less than SEK 500,000 or more than SEK 2,000,000, divided between a minimum of 44,737,320 and a maximum of 178,949,280 shares.

Thule Group's Articles of Association contain a central securities depository clause and the company's shares are registered with Euroclear Sweden AB, which means that Euroclear Sweden AB administers the company's share register. All shares carry equal rights to the company's profits and shares of surpluses in the event of liquidation.

## 10 LARGEST OWNERS

	No. of shares	Capital and votes, %
AMF Pension & Fonder	11,628,525	10.8
Swedbank Robur Fonder	8,464,603	7.9
Alecta Tjänstepension	4,847,639	4.5
Handelsbanken Fonder	4,446,693	4.1
Vanguard	3,907,822	3.6
ODIN Fonder	3,872,024	3.6
Columbia Threadneedle	3,832,246	3.6
SEB Investment Management	3,617,184	3.4
Nordea Funds	3,538,344	3.3
Norges Bank Investment Management	2,172,683	2.1
<b>Ten largest owners</b>	<b>50,327,763</b>	<b>46.7</b>
Other	57,510,399	53.3
<b>Total</b>	<b>107,838,162</b>	<b>100.0</b>

## SHARE TURNOVER AND SHARE PRICE 2024

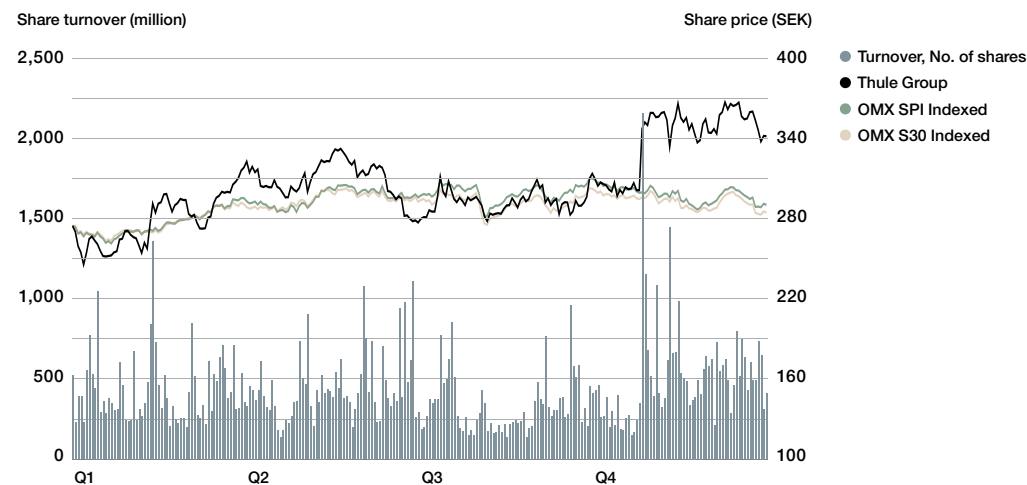

## SHARE OF VOTES AND CAPITAL, SWEDISH AND INTERNATIONAL OWNERS, %

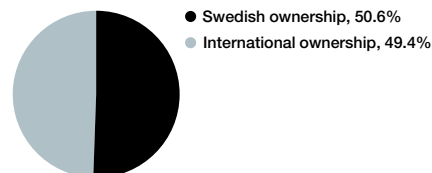

## SHARE OF VOTES AND CAPITAL, %

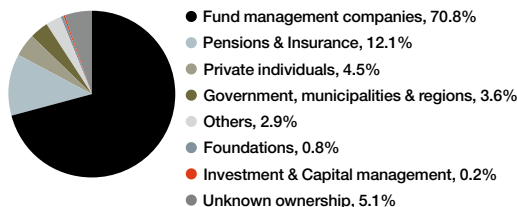

## OWNER BREAKDOWN, COUNTRIES IN CAPITAL, 7 LARGEST, %

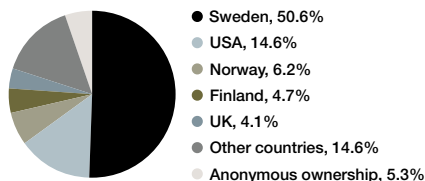

## SHARE TURNOVER IN THE LARGEST MARKET PLACES

SEKm	No. of shares	Share, %
Cboe	125,336,230	54.3
Nasdaq OMX	70,977,538	30.8
London Stock Exchange	22,062,762	9.6
Aquis Stock Exchange	4,820,390	2.1
ITG Posit	2,899,055	1.3
Liquidnet EU Limited Equity MTF	2,458,605	1.1
Sigma x	1,559,356	0.7
Instinet Blockmatch Europe	594,023	0.3
Boerse Berlin Equiduct Trading	7,383	0.00
<b>Total</b>	<b>230,715,342</b>	<b>100.00</b>

# Information to shareholders

The Annual General Meeting (AGM) of Thule Group AB (publ) will be held on April 29, 2025. Information about the resolutions passed by the General Meeting will be published in the customary General Meeting press release after the General Meeting.

## Right to attend the General Meeting

Shareholders who wish to attend the Annual General Meeting must:

- be recorded in the share register prepared by Euroclear Sweden AB (the Swedish Central Securities Depository) on April 17, 2025; and
- notify the company if they intend to attend in person at the Meeting venue or notify participation by casting their postal vote not later than April 23.

To be entitled to participate in the General Meeting, shareholders with nominee-registered shares must – in addition to submitting a notice to attend the General Meeting – request to be temporarily included in the share register prepared by Euroclear. Voting rights registered by nominees no later than April 17, 2025, will be taken into consideration when producing the share register.

## Voting by mail

The Board of Directors has resolved that shareholders must be able to exercise their voting rights through postal votes pursuant to the provisions of

the Articles of Association. A special form is to be used for postal voting.

The postal voting form is available on the Group's website: [www.thulegroup.com](http://www.thulegroup.com).

Completed and signed postal voting forms can be sent by mail to the address:

Thule Group AB (publ)  
Annual General Meeting 2025  
c/o Euroclear Sweden  
Box 191, SE-101 23 Stockholm

or by e-mail to [generalmeetingservice@euroclear.com](mailto:generalmeetingservice@euroclear.com). The completed forms must be delivered to Euroclear no later than April 23, 2025, preferably before 4:00 p.m.

Shareholders who are natural persons can also submit their postal votes electronically by using BankID authentication at Euroclear Sweden AB's website: <https://anmalan.vpc.se/EuroclearProxy/>.

Such electronic votes must be submitted no later than April 23, 2025. Shareholders may not enclose any special instructions or terms and conditions with their postal votes. The entire postal vote will be rendered invalid should this be the case. Additional instructions and terms and conditions are provided on the postal voting form and are available at <https://anmalan.vpc.se/EuroclearProxy>.

## Power of attorney

In the event that a shareholder is postal voting through a proxy, a written and dated power of attorney signed by the shareholder must be attached to the postal voting form.

A Form of Proxy can be provided on request and is also available at the Group's website: [www.thulegroup.com](http://www.thulegroup.com). If the shareholder is a legal entity, a registration certificate or other authorization document must be attached to the form.

## Entitlement of shareholder to disclosures

The Board of Directors and the CEO shall, if a shareholder should so request and if the Board of Directors deems that this can be undertaken without causing material damage to the company, disclose information at the General Meeting about circumstances that could impact the assessment of an item of business on the agenda, circumstances that could impact the assessment of the financial position of the company or its subsidiaries, and the company's relationship to other Group companies.

## IR Contact

Catharina Paulcén  
SVP Communications and Investor Relations  
[Catharina.Paulcen@thule.com](mailto:Catharina.Paulcen@thule.com)  
Tel: +46 (0)73-665 45 74  
[ir@thule.com](mailto:ir@thule.com)

## Financial calendar

### 2025

Interim report January to March	April 29
Annual General Meeting	April 29
Interim report April to June	July 15
Interim report July to September	October 22

### 2026

Year-end report	February 10
-----------------	-------------

# Financial definitions and alternative performance measures

## Financial definitions

**Gross margin**  
Gross income as a percentage of net sales.

**Gross income**  
Net sales less cost of goods sold.

**CAGR (Compound Annual Growth Rate)**  
A measure of the growth rate achieved over a defined period as if the growth rate were the same each year over the defined period (expressed in percent).

**EBIT margin/Operating margin**  
EBIT as a percentage of net sales/Operating income as a percentage of net sales.

**EBIT – Operating income**  
(Earnings before interest and taxes) Income before net financial items and taxes.

**EBITDA – Operating income before depreciation/amortization/impairment**  
(Earnings before interest, taxes, depreciation and amortization) Income before net financial items, taxes, depreciation/amortization and impairment of tangible and intangible assets.

**Adjusted operating income (adjusted EBIT)**  
Operating income adjusted for transaction costs related to the acquisition of Quad Lock in the fourth quarter of 2024.

**Adjusted operating margin**  
Adjusted operating income as a percentage of net sales.

**Adjusted EBITDA – Operating income before depreciation/amortization/impairment**  
EBITDA adjusted for transaction costs related to the acquisition of Quad Lock.

**Organic growth, currency-adjusted**  
The change in net sales for the period adjusted for structural changes and currency effects. Organic

growth excludes the effects of structural changes in the Group's structure and exchange rates, which enables the comparison of net sales over time, excluding the effects of acquisitions for example.

**Net sales growth, currency-adjusted**  
The change in net sales for the period adjusted for currency effects.

**Net debt**  
Gross debt less cash and cash equivalents. Gross debt is the total of long- and short-term borrowing, derivative instruments, capitalized transaction costs and accrued interest. Net debt is a metric used for monitoring the debt trend and the scope of financing requirements. Since cash and cash equivalents can be used to repay debt at short notice, net debt is used instead of gross debt as a metric for total loan financing.

**LTM**  
Rolling 12-month.

**Earnings per share**  
Net income for the period divided by the average number of shares during the period.

**Leverage ratio**  
Net debt divided by EBITDA (LTM). This APM is a debt ratio that indicates how many years it would take to repay the company's debt, provided that its net debt and EBITDA are constant, without factoring cash flows pertaining to interest, tax and investments.

**Leverage ratio PRO FORMA**  
Net debt divided by pro forma EBITDA. Pro forma EBITDA (LTM) includes Quad Lock's earnings if the company had been part of the Group for the last 12 months.

**Equity ratio**  
Equity as a percentage of total assets.

## Alternative performance measures

Alternative performance measures are used to describe the underlying development of operations and to enhance comparability between periods. These are not defined under IFRS but correspond to the methods applied by Group management and the Board of Directors to measure the company's financial performance. These performance measures should not be viewed as a substitute for financial information presented in accordance with IFRS but rather as a complement.

	2024	2023
<b>Organic growth, currency-adjusted</b>		
Change in net sales, %	4.5	-9.9
Exchange rate fluctuations, %	0.2	-5.2
<b>Net sales, currency-adjusted growth, %</b>	4.7	-15.2
Structural changes	-1.2	—
Organic growth, %	3.5	-15.2
<b>Adjusted operating income (adjusted EBIT)</b>		
Operating income (EBIT), SEKm	1,522	1,505
Transaction costs related to Quad Lock Acquisition, SEKm	100	—
<b>Adjusted operating income, SEKm</b>	<b>1,622</b>	<b>1,505</b>
<b>Adjusted EBITDA</b>		
Adjusted operating income (adjusted EBIT), SEKm	1,622	1,505
Add back of depreciation/amortization and impairment, SEKm	282	259
<b>Adjusted EBITDA, SEKm</b>	<b>1,904</b>	<b>1,763</b>
<b>Net debt</b>		
Long-term interest-bearing liabilities, gross, SEKm	4,315	2,033
Derivative liabilities, long-term, SEKm	7	7
Short-term interest-bearing liabilities, SEKm	75	102
Derivative liabilities, short-term, SEKm	2	34
Capitalized financing costs, SEKm	-21	-2
Accrued interest, SEKm	2	1
<b>Gross debt, SEKm</b>	<b>4,380</b>	<b>2,175</b>
Derivative assets, SEKm	-15	-75
Cash and cash equivalents, SEKm	-405	-94
<b>Net debt, SEKm</b>	<b>3,961</b>	<b>2,006</b>

	2024	2023
<b>Leverage ratio</b>		
Net debt, SEKm	3,961	2,006
EBITDA, SEKm	1,804	1,763
Leverage ratio	2.2	1.1
<b>Leverage ratio, pro forma</b>		
Net debt, SEKm	3,961	2,006
EBITDA, pro forma, SEKm	2,169	1,763
Leverage ratio, pro forma	1.8	1.1
<b>Equity ratio</b>		
Equity, SEKm	8,095	6,849
Total assets, SEKm	14,957	10,966
Equity ratio, %	54.1	62.5

# Five-year overview

	2024	2023	2022	2021	2020
<b>Results and key figures</b>					
Net sales, SEKm	9,541	9,132	10,138	10,386	7,828
Net sales growth, %	4.5	-9.9	-2.4	32.7	11.2
Net sales growth, currency-adjusted, %	4.7	-15.2	-9.7	37.7	13.1
Net sales organic growth, currency-adjusted, %	3.5	-15.2	-9.7	37.7	13.1
Gross income, SEKm	4,074	3,737	3,859	4,160	3,230
Operating margin, %	42.7	40.9	38.1	40.1	41.3
EBITDA, SEKm	1,804	1,763	1,906	2,493	1,737
Adjusted operating income, SEKm	1,622	—	—	—	—
Adjusted operating margin, %	17.0	—	—	—	—
Operating income (EBIT), SEKm	1,522	1,505	1,706	2,340	1,591
Operating margin, %	15.9	16.5	16.8	22.5	20.3
Net income, SEKm	1,122	1,099	1,275	1,790	1,166
<b>Financial position and key figures</b>					
Total assets, SEKm	14,957	10,966	11,679	10,192	8,448
Equity, SEKm	8,095	6,849	6,553	5,815	5,253
Net debt, SEKm	3,961	2,006	2,868	1,467	384
Leverage ratio, pro forma	1.8	—	—	—	—
Leverage ratio	2.2	1.1	1.5	0.6	0.2
Equity ratio, %	54.1	62.5	56.1	57.1	62.2
<b>Cash flow</b>					
Cash flow from operating activities, SEKm	2,310	1,850	616	1,128	1,614
Investments excl. business acquisitions, SEKm	264	251	444	507	173

	2024	2023	2022	2021	2020
<b>Other Key figures</b>					
Weighted average number of shares, million	105.9	105.2	104.6	104.6	103.8
Earnings per share before dilution, SEK	10.59	10.45	12.19	17.12	11.23
Ordinary dividend as percentage of earnings per share, %	78	91	75	76	71
Ordinary dividend as percentage of net income, %	80	91	75	76	72
Extraordinary dividend as percentage of net income, %	—	—	—	—	67
Dividend as a percentage of earnings per share for the year after adjustment for transaction costs pertaining to the acquisition of Quad Lock, %	75	—	—	—	—
Average number of employees	2 808	2 559	2 799	3 303	2 669

In accordance with the requirements of the Fighting Against Forced Labour and Child Labour in Supply Chains Act (Act), and in particular section 11 thereof, I, Toby Lawton, in the capacity of CFO, attest that I have reviewed the information contained in the report on behalf of the governing body of the entity [or entities] listed above. Based on my knowledge, and having exercised reasonable diligence, I attest that the information in the report is true, accurate and complete in all material respects for the purposes of the Act, for the reporting year listed within this report.

I have the authority to bind Thule Canada Inc



---

Toby Lawton  
Chief Financial Officer  
October 24, 2025

**THULE**  
SWEDEN



DESIGN & PRODUCTION: STHLM KOMMUNIKATION & IR AB.

Thule Group AB / Fosievägen 13, SE-214 31 Malmö Sweden / Tel: +46 (0)40-635 90 00 / [thulegroup.com](http://thulegroup.com) / [info@thule.com](mailto:info@thule.com)